

Operating Manual

Linear actuators with spring reset device

MLH253ZC • MLH253ZA

General information

| Amendment | Version | Date | Modifications |
|------------------|----------------|-------------|----------------------|
| | 1.0 | June 2010 | Initial preparation |
| | 1.1 | March 2011 | Revision |

Copyright The copyright for this operating manual as well as all rights in case of patent awarding or registration of registered design remains with the manufacturer!

Subject to alteration The regulations, directives, standards etc. are compliant with the current state of information at the time of development and are not subject to modification service. They must be applied by the operator at his own responsibility in their latest valid version.

Concerning all data, information, and illustrations in this manual we reserve the right of technical modifications and improvements. No claims can be considered for alteration or rework of already delivered lift drives.

Inhalt

| | | | |
|--|-----------|--|-----------|
| 1 Safety | 4 | 4 Assembly | 14 |
| 1.1 Proper use | 4 | 4.1 Checking the scope of delivery | 14 |
| 1.2 Information for the operator | 4 | 4.2 Preparing assembly | 14 |
| 1.3 Personnel..... | 5 | 4.3 Mounting the linear actuator on the valve | 15 |
| 1.4 Prior to starting work..... | 5 | 4.4 Assembling/disassembling the cover..... | 17 |
| 1.5 During operation | 5 | 4.5 Electrical connection | 18 |
| 1.6 Working environment..... | 5 | 4.5.1 Controller independent circuit | 20 |
| 2 Product Specification | 6 | 4.6 Optional extras installation | 21 |
| 2.1 Components | 7 | 4.6.1 Way-switch printed circuit board | |
| 2.2 Accessories | 8 | installation..... | 21 |
| 2.3 Operating modes | 8 | 4.6.2 Fit the printed circuit board for mA | |
| 2.3.1 Continuous mode | 8 | output signal. | 22 |
| 2.3.2 Three-point mode | 9 | 5 Commissioning | 24 |
| 2.4 Functions | 9 | 5.1 Operating parameters and coding | |
| 2.4.1 Binary signal / Frost protection function | 9 | switch positions | 24 |
| 2.4.2 Lock detection | 9 | 5.2 Set input signal..... | 25 |
| 2.4.3 Internal temperature monitoring | 9 | 5.3 Set actuating time | 25 |
| 2.4.4 Open-circuit detection..... | 10 | 5.4 Set hysteresis..... | 26 |
| 2.4.5 Set time | 10 | 5.5 Set actuating direction..... | 26 |
| 2.4.6 Hysteresis..... | 10 | 5.6 Set Autotest and Autopause | 26 |
| 2.4.7 Manual mode and feedback signal..... | 10 | 5.7 Set limit position | 27 |
| 2.4.8 Autotest | 11 | 5.8 Set potential-free way-switch | 27 |
| 2.4.9 Autopause | 11 | 5.9 Initialising the path measuring system | 29 |
| 2.4.10 Potential-free way-switch (optional extra)..... | 11 | 5.10 Commissioning..... | 30 |
| 2.5 Technical data | 12 | 6 Operation | 31 |
| 2.6 Type plate | 13 | 6.1 Changing between manual and automatic mode... 31 | |
| 3 Transportation & Storage | 13 | 6.2 LED display..... | 32 |
| | | 7 Maintenance, Care and Repairs | 32 |
| | | 8 Spare parts | 32 |
| | | 9 Shutdown and Disposal | 33 |
| | | 10 Troubleshooting | 33 |
| | | 10.1 Troubleshooting | 33 |
| | | 10.2 Operating faults checklist..... | 34 |

1 Safety

Read these Operating Instructions carefully particularly the following safety instructions prior to installation and operation.



DANGER

Directly threatening hazard leading to death or serious physical injuries.



WARNING

Potentially hazardous situation which may lead to death or serious physical injuries.



CAUTION

Potentially hazardous situation which could lead to minor physical injuries. Indicates a hazard which may cause material damage.



ATTENTION

Potentially hazardous situation where the product or an object in its environment may get damaged.

Hint: Utilisation instructions and other useful information.

1.1 Proper use

Linear actuator MLH253ZC, MLH253ZA are controlled by three-point control or constant control. Linear actuators in the series described in these Operating Instructions are used for valve stroke adjustment.

Concurrence of the above type designation with the linear actuator rating plate must be checked prior to starting any operations in order to guarantee utilisation in accordance with specification. The data on the rating plate is decisive for linear actuator technical data and mains power supply requirements.

Any utilisation for tasks other than the aforementioned usage in accordance with specification and operating with mains power supply ratios other than those permitted is not deemed to be utilisation in accordance with specification. The operator bears sole liability for the risk to persons and machine and other assets in the event of utilisation not in accordance with specification.

The intended use also includes the compliance with accident preventions, DIN VDE regulations and safe working practices for all measures described in these operating instructions in due consideration of prevailing rules.

1.2 Information for the operator

Always keep the Operating Instructions available at the linear actuator deployment site.

Observe the current health and safety, accident prevention and DIN VDE standards for installation, operation and maintenance.

Take into consideration any additional regional, local or in-house safety regulations.

Ensure that every person entrusted with one of the tasks specified in these Operating Instructions has read and understood these instructions.

1.3 Personnel

Only qualified personnel may work on these linear actuators or in their vicinity. Qualified persons are those persons entrusted with installation, assembly, commissioning and operation or maintenance of the linear actuators and possessing the appropriate qualifications for their activity. The necessary and prescribed qualifications include:

- Training / instruction or authorization to turn on /off circuits and appliances / systems according to EN 60204 (DIN VDE 0100 / 0113) and the standards of safety technology.
- Training or instruction according to the standards of the safety technology concerning care and use of adequate safety and work protection equipment.
- First Aid training.

Work in a safe manner and refrain from any working practice which endangers the safety of persons or damages the linear actuator or other assets in any way whatsoever.

1.4 Prior to starting work

Prior to starting any work, check that the type designations specified here concur with the data on the linear actuator rating plate.

Linear actuator MLH253ZC, MLH253A.

1.5 During operation

Safe operation is only possible if transportation, storage, installation, operation and maintenance are carried out safely and materially and professionally correctly.

Transportation, installation and assembly

Observe the general set-up and safety regulations for heating, ventilation, air-conditioning and pipework design. Use tools correctly. Wear the necessary personal and other safety equipment.

Repairs and maintenance

Ensure that qualified personnel switch off the linear actuator prior to maintenance or repair work in accordance with DIN VDE.

1.6 Working environment

Read the data concerning the working environment in the Technical Data.

2 Product Specification

The linear actuator is used to actuate and adjust lift valves. The lifting movement is generated by means of a spindle actuator coupled to a valve spindle comprising a pivoted spindle and a spindle nut secured against skewing. The actuation of the ball bearing mounted spindle is achieved by means of a stepper motor with interconnected two-step planetary gear. The stepper motor receives the rotary field required for operation from a micro controller based electric control.

The linear actuator comprises a spring reset device with an electro-hydraulically blockable spring. On commissioning the spring is tensed inside the hydraulic unit by the spindle actuator and blocked electro-hydraulically when reaching spring limit position. During a cut of supply voltage this spring will be unlocked and the clutch piece will move hydraulically dampened to the lower limit position – actuator spindle.

2.1 Components

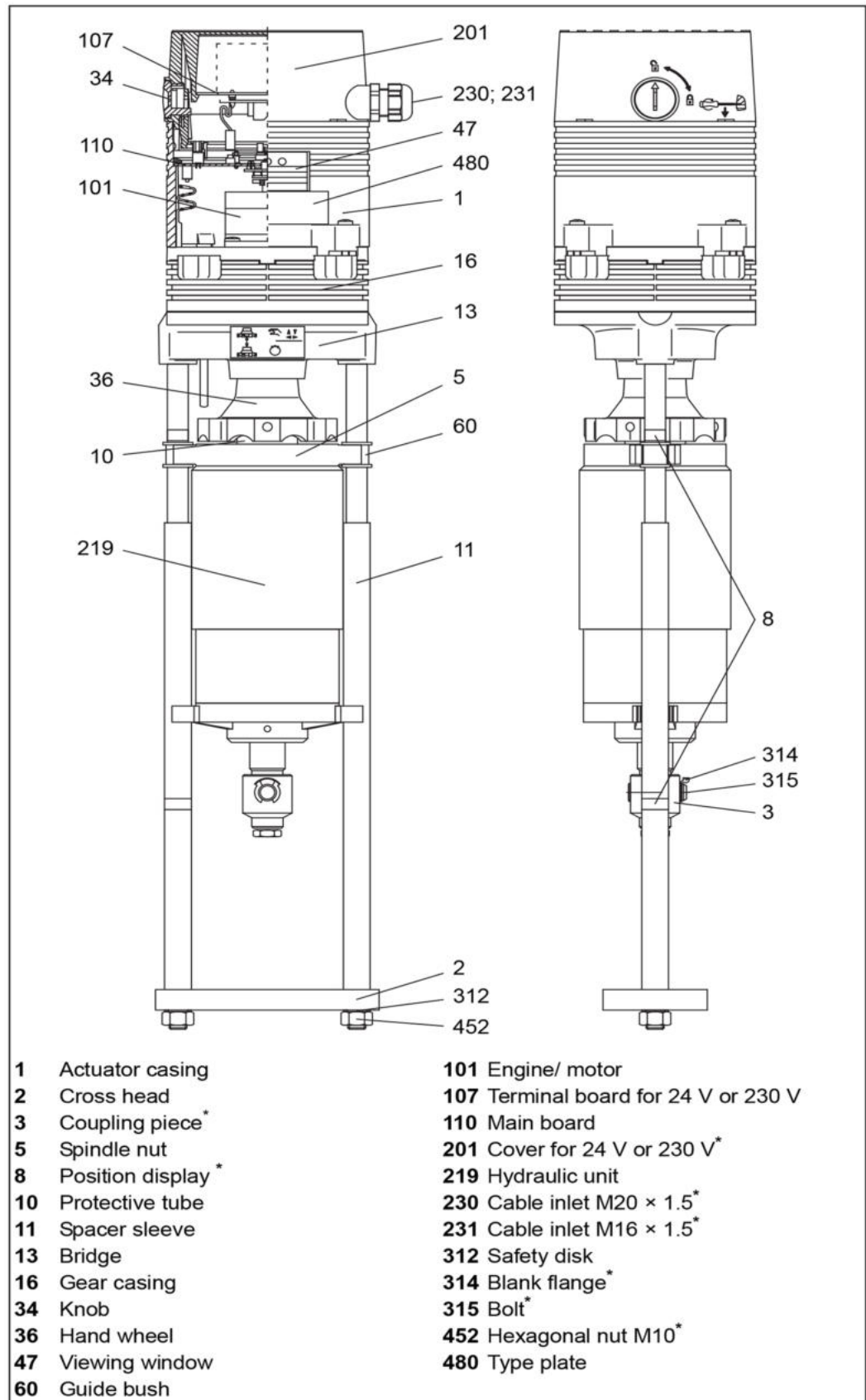
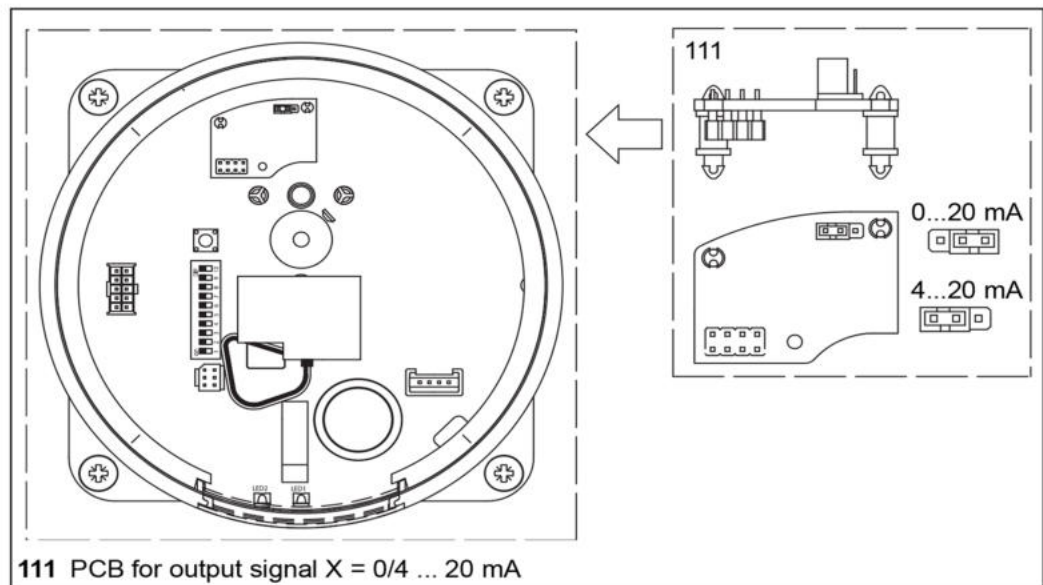

diagram 1 Component drawings

* This component is available as a spare part!

2.2 Accessories



111 PCB for output signal X = 0/4 ... 20 mA

diagram 2 PCB for mA output signal in cover

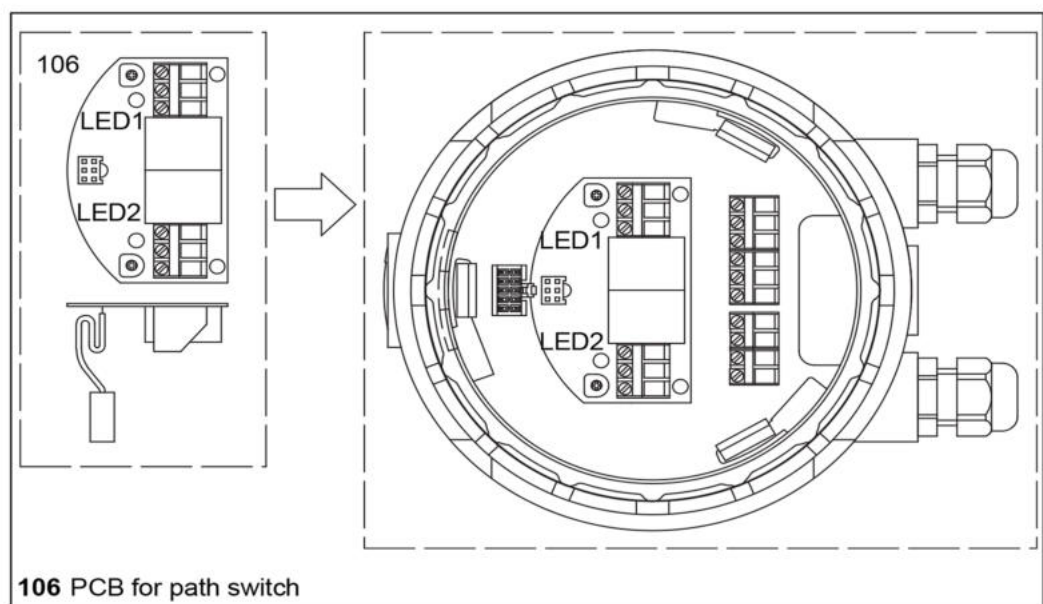

106 PCB for path switch

diagram 3 Position switch PCB in cover

2.3 Operating modes

The linear actuator can be operated manually or automatically.

- In manual mode stroke is adjusted via the hand wheel.
- In automatic mode stroke is controlled electrically.

2.3.1 Continuous mode

In continuous mode the system control presets the position of the linear actuator whilst inside the linear actuator the input signal (Y) of the system control is continuously compared with the output signal (X) of the linear actuator. In doing so the output signal depends on the position of the linear actuator (travel).

The linear actuator keeps moving until the input signal and the output signal match.

Input signal (Y) The input signal (Y) from the system control specifies the reference position for the linear actuator. It is an analogue signal on terminal Y.

The following input signals are possible:

- 0 ... 10 V DC / 2 ... 10 V DC
- 0 ... 20 mA / 4 ... 20 mA

Output signal (X) The output signal (X) specifies the actual position of the linear actuator. It is an analogue signal on terminal X.

0% to 100% valve lift is output as:

- 0 ... 10 V DC
- 0 ... 20 mA or 4 ... 20 mA (Printed circuit board for output signal as optional extra **(111)**)

2.3.2 Three-point mode

The direction of movement is specified via a control voltage on terminal 2 and terminal 3 on the motherboard:

- If the control voltage on terminal 2 is on, the spindle nut extends.
- If the control voltage on terminal 3 is on, the spindle nut retracts.

2.4 Functions

2.4.1 Binary signal / Frost protection function

Terminals B1 and B2 on the motherboard are bridged in Normal mode. If the circuit between B1 and B2 is broken, the linear actuator stores the actual position and then moves automatically to its limit position.

All other control signals are ignored during this process.

The linear actuator remains in the limit position until the circuit between B1 and B2 is closed again.

- In Three-point mode the linear actuator then returns automatically to the stored position.
- In Continuous mode the reference value of the input signal is again approached.

2.4.2 Lock detection

If the linear actuator becomes mechanically locked, it returns briefly and tries again to reach the required position. If this does not happen after a total of 7 attempts, the linear actuator is switched off to avoid damage to linear actuator and actuator.

The lock detection is displayed via the green LED in the **(60)** viewing window.

⇒ *Table 7* on page 32

2.4.3 Internal temperature monitoring

The actuator has internal temperature monitoring.

Overheating protection If the temperature in the actuator casing exceeds a limit value, the motor will be switched off. Once the motor has cooled down, it is automatically switched on again.

Actuator heating If the temperature in the actuator drops below 15 °C, the motor is switched to heating in the operating pauses. The actuator heating switches off automatically at a constant temperature of approx. 22 °C. The actuator heating does not affect the functions of the actuator.

Heating capacity:

- 12.5 W at temperatures from approx. 8 °C to approx. 15 °C
- 18 W at temperatures below 8 °C

The heating prevents the build-up of water condensation in the actuator and at the same time guarantees the smooth running of the gears even at temperatures up to approx. - 10°C.

Heating operation and motor switch-off are displayed via the LED in the **(60)** viewing window.

⇒ *Table 8 Red LED display on page 32*

2.4.4 Open-circuit detection

Open-circuit detection is only available in Continuous mode with an input signal 2 ... 10 V DC and 4 ... 20 mA.

If the input signal drops below 1 V or 2 mA in Continuous mode, the linear actuator moves to the limit position set by coding switch S7.

Open-circuit detection is displayed via the green LED in the viewing window.

⇒ *Table 7 Green LED display on page 32*

2.4.5 Set time

The time the spindle nut takes to travel a defined path, is called actuating time. The actuating time is indicated in s/mm. The actuating time is set by coding switch S5.

⇒ *5.3 Set actuating time on page 25*

2.4.6 Hysteresis

The differential of the input signal (Y) required after a reversal of the signal direction so that the spindle nut is moved, is called hysteresis.

It is used to avoid permanent oscillation of the actuator motor around a specific lift position in the event of slight input signal changes.

⇒ *5.4 Set hysteresis on page 26*

2.4.7 Manual mode and feedback signal

The lift can be manually changed in Manual mode without power supply.

- The electronic motor and control are switched off in Manual mode so that lift movements by the control are not possible.
- As soon as the linear actuator is switched to Manual mode, the control switches a signal to Terminal R, if the power supply is on.

⇒ *6.1 Changing between manual and automatic mode on page 31*

2.4.8 Autotest

If a valve is not actuated over a long period, the valve cone may seize. The Autotest function prevents this. If the Autotest function of the linear actuator is switched on, the linear actuator moves after approx. 10 days without actuation automatically in rapid traverse to the limit position set by coding switch S7 and returns to the starting position.

⇒ 5.6 Set Autotest and Autopause on page 26

2.4.9 Autopause

The actuator uses this function to count the actuator commands which mean a change in direction. In the event of more than 20 different directional actuator commands per minute, a compulsory pause of 3 s is imposed.

⇒ 5.6 Set Autotest and Autopause on page 26

2.4.10 Potential-free way-switch (optional extra)

The optional way-switch printed circuit board **(106)** can be used to set two lift positions at which a potential-free electrical contact is opened or closed.

⇒ 5.8 Set potential-free way-switch on page 27

2.5 Technical data

| Type | MLH253ZC | MLH253ZA |
|--|--|--|
| Supply voltage | 24 V AC \pm 10% | 115 V AC \pm 10% 230 V AC + 6% -10% |
| Power consumption | max. 50 VA | max. 80 VA |
| Weight | 12 kg | 12.5 kg |
| Dimensions | See technical data sheets (www.hora.de) | |
| Stroke | max. 40 mm | max. 40 mm |
| Frequency | 50/60 Hz \pm 5% | 50/60 Hz \pm 5% |
| Ambient temperature | 0 to +60°C | 0 to +60°C |
| Enclosure protection | IP 54 | IP 54 |
| | Suitable for use in the usual environment | |
| Operating mode | S3-50% ED | S3-50% ED |
| Actuating time | 2.5 or 5 s/mm | 2.5 or 5 s/mm |
| Emergency actuating time | 0.1 s/mm | 0.1 s/mm |
| Actuating force | 2.5 kN | 2.5 kN |
| Recommended external protection | T4 A | T1 A (115 V) T800 mA (230 V) |
| Temperatur limits transformer cover | | T60 (EN60730 6.7; 14.5; 14.7; 17.3) |
| Surge voltage rating | Overvoltage category 2 (EN60730 20.1.12; 20.1) | |
| Ball pressure testing temperature | Ball pressure test 1 test temperature 140°C (EN60730 21.2.5) | |
| Function | Control function according to EN 60730 = 1 Spring return function according to EN 60730 = 2 | |

table 1 Technical data

| | |
|---|--|
| Input signal Y/ Resistance of load | <ul style="list-style-type: none"> • 0 ... 10 V DC / 77 kΩ • 2 ... 10 V DC / 77 kΩ • 0 ... 20 mA / 510 Ω • 4 ... 20 mA / 510 Ω |
| Output signal X/ Load rating | <ul style="list-style-type: none"> • 0 ... 10 V DC / resistance of load \geq 1200 Ω, I_{max.} 8 mA • 0 ... 20 mA / resistance of load \leq 500 Ω - with accessory PCB for output signal (111) • 4 ... 20 mA / resistance of load \leq 500 Ω - with accessory PCB for output signal (111) |
| Response signal R/ load rating | • 24 V DC / minimum impedance \geq 480 Ω / I _{max.} 35 mA |
| Cable impedance between B1 and B2 | • max. 10 Ω |

table 2 Technical data signals

2.6 Type plate

The type plate is attached to the housing of the linear actuator.

It bears the type denomination, serial number (s/no) and date of manufacture (last four digits).

⇒ 2.1 Components on page 7

| | | | | | |
|--------------------------|-----------|----------|------------------|---|--|
| | | | |  CE | |
| MLH253ZA | | | | | |
| F.-Nr.: 09200000/01/0310 | | | Zertifikats-Nr.: | | |
| AC 50 Hz 230 V | 80 VA | 2,5 kN | Hub 40 mm | T60 | |
| Y= 3-Punkt | IP 54 | 5 s/mm | Stellzeit | | |
| X= 0...10 V DC | S3-50% ED | 0,1 s/mm | Rückstellzeit | | |

diagram 4 Example of type plate

3 Transportation & Storage



Non-compliance with safety regulations may result in injury!

- Wear the required personal and other safety equipment.

- Avoid impacts, blows, vibrations etc. to the linear actuator.
- Store the linear actuator (and, where appropriate, the entire controlling device) in a dry place.
- Keep to the specified transport and storage temperatures between -20 to +65°C.

4 Assembly

Prior to assembling the linear actuator:

⇒ 4.1 *Checking the scope of delivery* on page 14

⇒ 4.2 *Preparing assembly* on page 14

The following sequence of operations is part of the linear actuator assembly:

⇒ 4.3 *Mounting the linear actuator on the valve* on page 15

⇒ 4.4 *Assembling/disassembling the cover* on page 17

⇒ 4.5 *Electrical connection* on page 18

4.1 Checking the scope of delivery

- 1 Check the packaging for damage.
- 2 Dispose of packaging in an environmentally friendly manner.
- 3 Check the delivered items against the delivery note in order to see whether the delivery is complete.
- 4 Report any missing or damaged products to the manufacturer.

4.2 Preparing assembly



A non-attached valve causes damage!

If you operate the linear actuator without valve, the spindle nut may fall off due to the missing stop.

- Always operate the linear actuator with a valve attached.

- 1 Allow for about 140 mm space above the cover at the site of installation.
- 2 Check the working environment before assembling and commissioning the linear actuator:
- 3 Ensure that the valve is correctly fitted. For details please see assembly instructions for valve.
- 4 Determine the assembly position of the linear actuator. Do not arrange linear actuators in a hanging position.

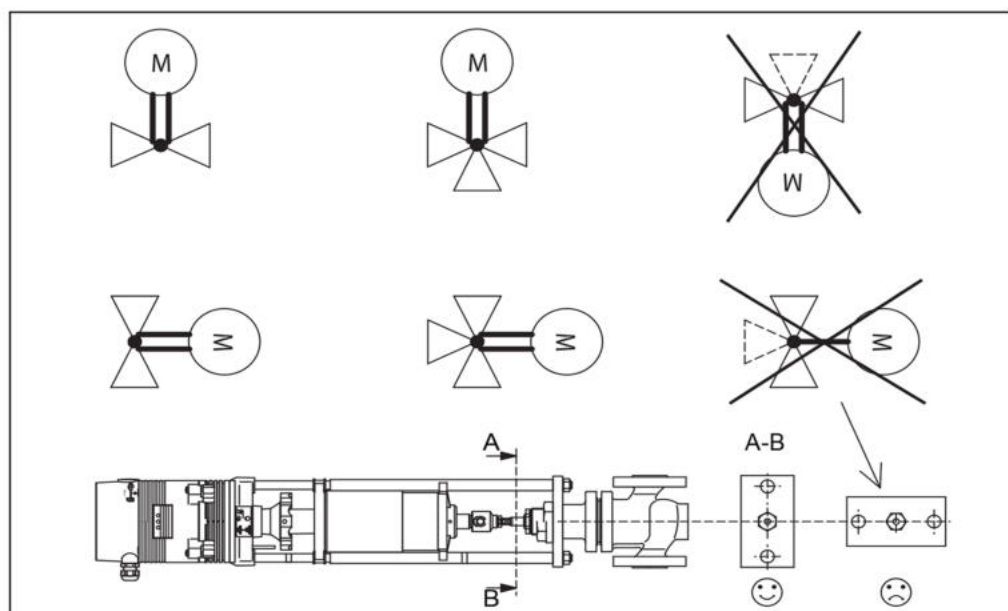

diagram 5 Assembly positions for linear actuator and valve

4.3 Mounting the linear actuator on the valve

If the linear actuator and the valve are supplied separately you will have to mount the linear actuator on the valve.

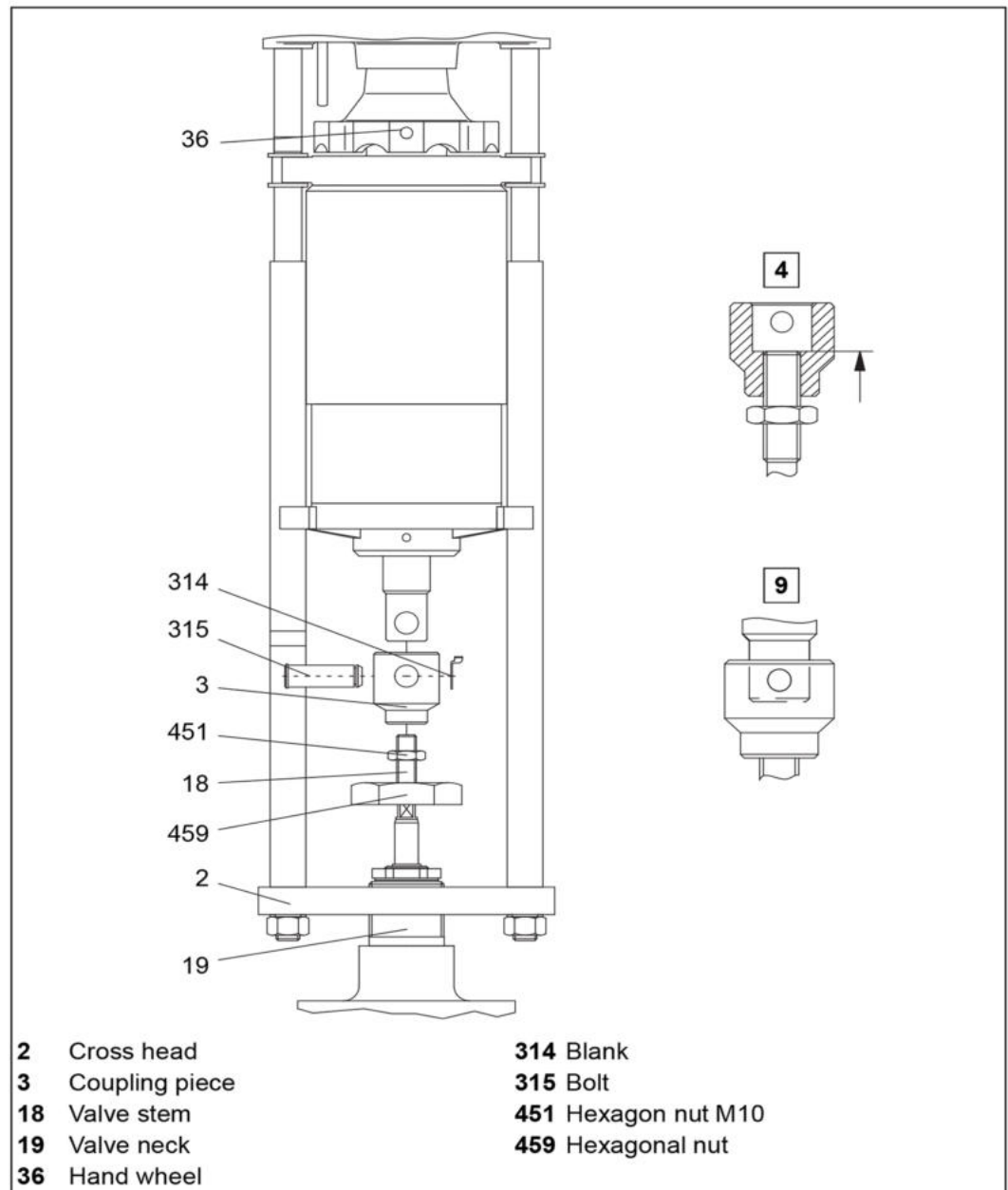

diagram 6 Mounting the linear actuator on the valve

■ How to assemble linear actuator type MLH253Z :

- 1 Pull off the blank (**314**).
⇒ *diagram 6 Mounting the linear actuator on the valve on page 15*
- 2 Pull out the bolt (**315**) from the clutch piece (**3**) or drive it out.
- 3 Screw the hexagon locknut M10 (**451**) spanner width 17 onto the valve stem (**18**).
- 4 Screw the clutch piece (**3**) onto the valve spindle (**18**). The area of the valve stem (**18**) must be flush with the area of the clutch piece (**3**).
⇒ *diagram 6 Mounting the linear actuator on the valve on page 15 (Detail 4).*

- 5 Put the actuator into upper limit position by means of the hand wheel **(36)** and check whether it has reached the upper limit position.
 - 6 Fit the actuator and crossbeam **(2)** and hexagon nut **(459)** on the valve neck **(19)**. Make sure that the valve spindle is in bottom position.
 - 7 Fix the crossbeam **(2)** using the hexagon nut **(459)** hand tight.
 - 8 Turn the clutch piece **(3)** until both borings are congruent.
⇒ *diagram 6 Mounting the linear actuator on the valve on page 15 (Detail 9).*
 - 9 Turn the clutch piece anti-clockwise by **(3)** one rotation (360°).
 - 10 Loosen the hexagon nut **(459)** spanner width 50 and lift the actuator by c. 1.5 mm.
 - 11 Insert the bolt **(315)** in the clutch piece **(3)** and secure it with a blank **(314)**.
 - 12 Tighten the hexagon nut **(459)** spanner width 50.
 - 13 Fix the valve stem **(18)** by hexagon locknut M10 **(451)** spanner width 17 in order to secure it against skewing.
- **How to disassemble the linear actuator**
- 1 Move the linear actuator to the upper limit position (MAN / AUTO).
 - 2 Turn the actuator by two rotations of the hand wheel away from the limit position.
 - 3 Loosen the hexagon nut **(459)** spanner width 50.
 - 4 Pull off the blank **(314)**.
 - 5 Pull out the bolt **(315)** from the clutch piece **(3)** or drive it out.
 - 6 Remove the actuator.

4.4 Assembling/disassembling the cover

The cover contains the terminals for electric connection.



Risk of injury from electric shock by live parts!

When the power supply is on there is a danger of electric shock due to live parts.

- Prior to commencing any work, ensure that the actuator is safely disconnected from the power supply system.
- Secure against unauthorised restarting.
- Remove the cover only momentarily.

■ How to remove the cover

- 1 Insert a screwdriver in the notch of the cover and lift the cover **(201)**.

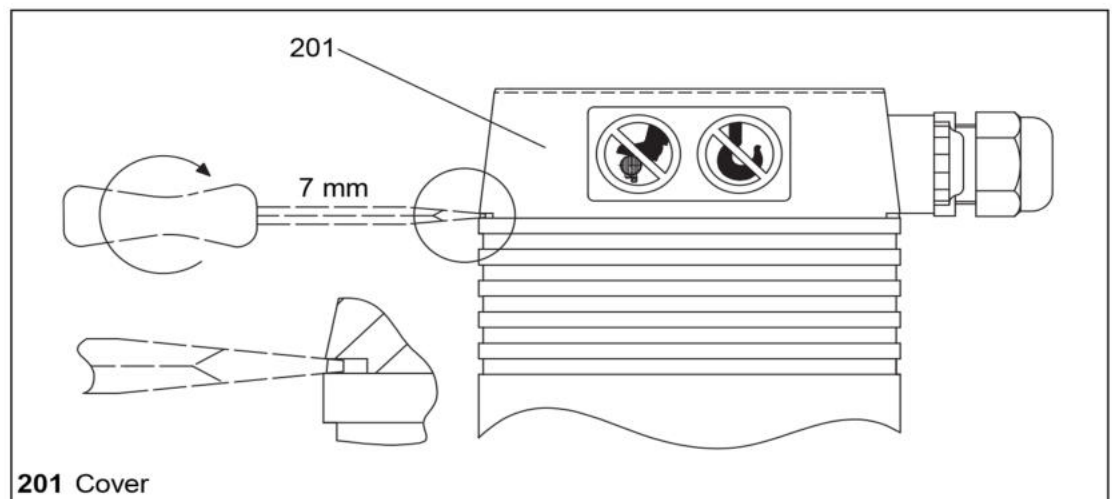

diagram 7 Removing the cover



Damaged cables result in damage to devices!

When lifting the cover you may tear off or damage the cabling inside the cover.

- Carefully remove the cover.

- 2 Remove the cover **(201)** carefully.
- 3 Disconnect the plug-in connection between the main PCB and the **(110)** cover **(201)**.

■ How to attach the cover

- 1 Plug the previously pulled off cables back into the main PCB **(110)**.
Pay attention to the notches on plug and socket.

Hint: You can mount the cover **(201)** in four, different, positions each of which is transposed by 90°. This allows the best possible laying of the connecting cable for different installations of the linear actuator.

- 2 Place the cover **(201)** on top and push it down to make it fit by applying moderate force.
- 3 Check the cover for correct fit to ensure air-tightness for the actuator housing.

4.5 Electrical connection



Danger of life caused by incompetent staff!

Electrical connections carried out by unqualified staff may result in death, severe bodily injury or considerable material damage.

- Make sure that such all work is carried out by qualified staff.
- ⇒ 1.3 *Personnel* on page 5



Risk of injury from electric shock by live parts!

When the supply voltage is turned on there is a risk of electric shock from live parts.

- Prior to commencing any work, ensure that the actuator is safely disconnected from the power supply system.
 - Secure against unauthorised restarting.
-

■ **How to prepare the electric connection**

- 1 Ensure that the supply voltage matches the specifications on the type plate of the linear actuator.
- 2 To avoid breakdown, construct the line diameter according to actuating performance and required line length.
- 3 Lay the mains for a supply voltage of > 48 V separate from the signal and control wires.

When laying cables in a joint cable duct, use shielded control wires.

- 4 Check the supply voltage.
If the required tolerance is not achieved by a power transformer you will have to use an AC voltage stabilizer.
⇒ 2.5 *Technical data* on page 12
- 5 Secure the power cables (e.g. with cable-binders) in order to prevent the cable sliding out from the connection terminal.
- 6 Ensure that there is fuse protection for the linear actuator.
⇒ 2.5 *Technical data* on page 12

■ **How to establish electrical connection**

- 1 Remove the cover (201).
⇒ *How to remove the cover on page 17*
- 2 Run the cable through the screw joint in the cover to the terminal.
- 3 Connect the power supply according to the wiring diagram.
⇒ *diagram 8 on page 19*



Malfunctions caused by incorrect zero potential!

If the electric power supply for the linear actuator is fed by transducing sensors with varying zero potentials this may result in incorrect automatic controller action.

- Ensure that the zero potential is properly applied.
- ⇒ *table 3 on page 20*

- 4 Tighten the screw joints.

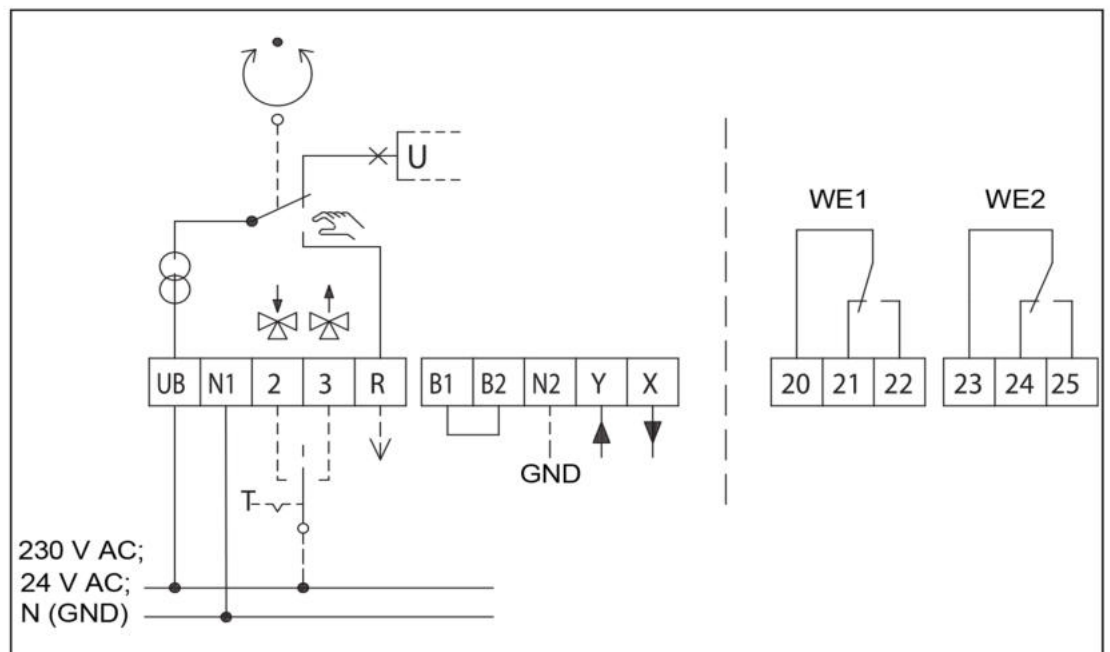

diagram 8 Circuit diagram

| Terminal | Description |
|-------------------|---|
| UB, N1 | Supply voltage |
| 2 | Control voltage for downward movement during three-point mode |
| 3 | Control voltage for upward movement during three-point mode |
| R | Response signal during “manual” mode <ul style="list-style-type: none"> • R= 24 V DC max. 35 mA |
| B1, B2 | Binary input / frost protection function |
| N2 | Zero potential of signals X, Y and R <ul style="list-style-type: none"> • When the zero potentials of signals X, Y and R are identical to the zero potential of the supply voltage it is possible to bridge terminals N1 and N2. • If you run the actuator in continuous mode at 230 V you will have to connect N2. • If you run the actuator in three-point mode at 230 V you will have to connect N2 if you wish to use X or R at the same time. |
| Y | Input signal continuous mode |
| X | Output signal continuous mode |
| 20, 21, 22 | Terminals path switch unit PS1 |
| 23, 24, 25 | Terminals path switch unit PS2 |

table 3 Key to wiring diagram

4.5.1 Controller independent circuit

When working with 24 V supply voltage and 0 ... 10 V DC / 2 ... 10 V DC input signal you can switch the actuator controller-independently via a three-step toggle switch in the control cabinet.

■ **How to switch the actuator controller-independently**

- 1 Run the supply voltage 24 V AC via a diode and a three-step toggle switch to terminal Y.

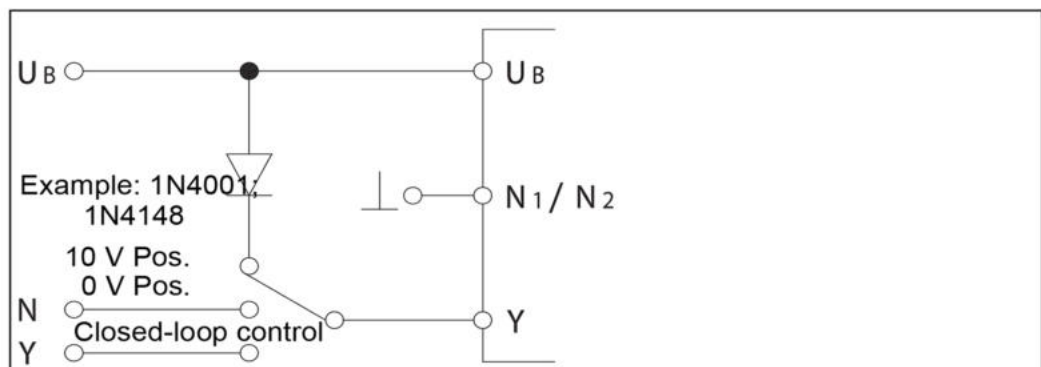

diagram 9 Controller independent circuit

- 2 Using the toggle you can move the linear actuator to the following positions:
 - Closed-loop control by input signal Y (normal operation)
 - 10 V-position
 - 0 V-Position, the linear actuator can be moved to the position selected by encoding switch S7 at 2 ... 10 V DC.

⇒ 5.1 Operating parameters and coding switch positions on page 24
⇒ 5.7 Set limit position on page 27

4.6 Optional extras installation

Optional extras are only part of the scope of supply of the linear actuator if expressly ordered! The linear actuators are prepared for retrofitting the following:

- Way-switch printed circuit board **(106)**
- Printed circuit board for output signal X=0/4 ... 20 mA **(111)**

⇒ 2.2 Accessories on page 8

4.6.1 Way-switch printed circuit board installation



Electric shock due to live components!

If the power supply is switched off, there is danger of electric shock due to live components.

- Prior to starting work ensure that the actuator is disconnected safely from the mains power supply.
- Secure against unauthorised switching-on.

- 1 Open the linear actuator **(201)** cover.
⇒ 4.4 Assembling/disassembling the cover on page 17
- 2 Press the way-switch printed circuit board **(106)** onto the terminal board **(27)** using the **(107)** three spacers.

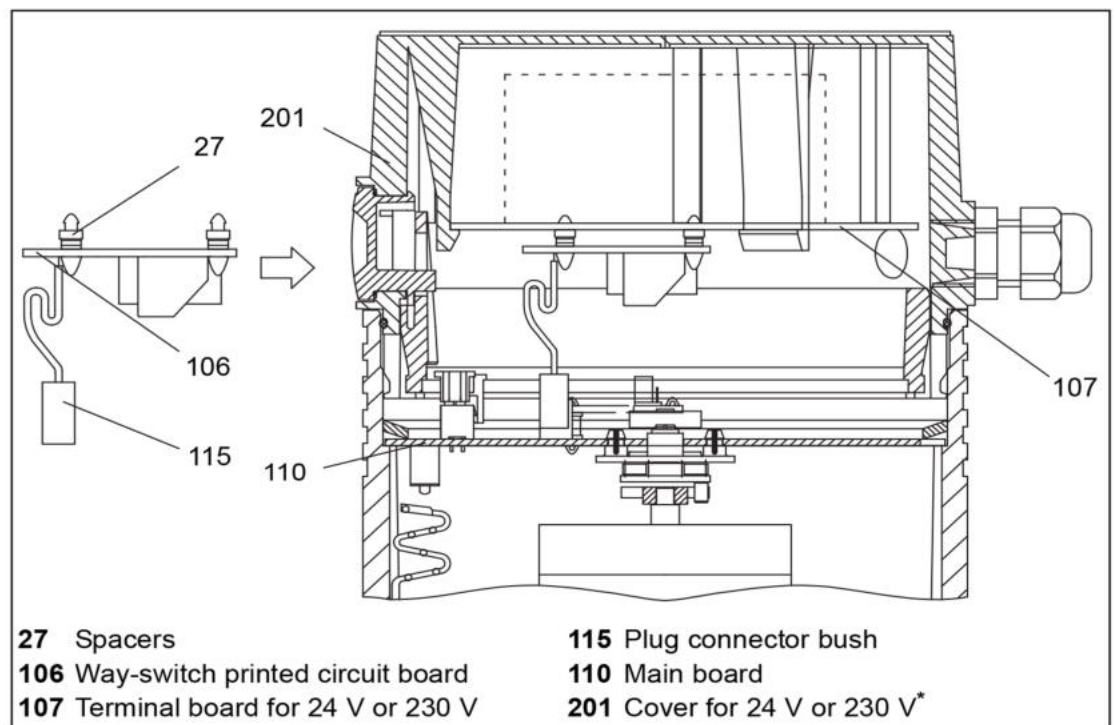

diagram 10 Installation of the way-switch printed circuit board in the cover

- 3 Place the plug connector bush **(115)** for the way-switch printed circuit board **(106)** on the pin strip **(123)** on the **(110)** motherboard. Pay attention to the grooves in the pin strip and plug connector bush.

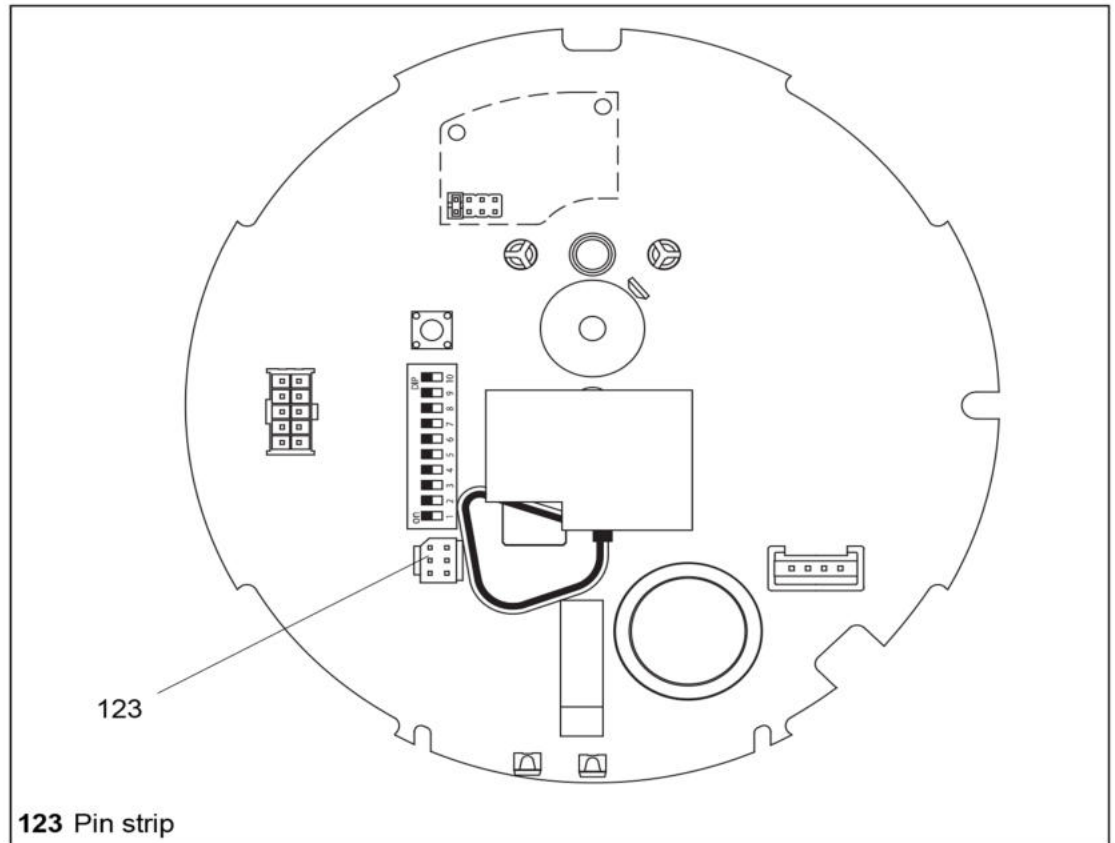

diagram 11 Pin strip for way-switch printed circuit board on the motherboard

- 4 Adjust the way-switch.
⇒ 5.8 Set potential-free way-switch on page 27

4.6.2 Fit the printed circuit board for mA output signal.



WARNING

Electric shock due to live components!

If the power supply is switched off, there is danger of electric shock due to live components.

- Prior to starting work ensure that the actuator is disconnected safely from the mains power supply.
- Secure against unauthorised switching-on.

- 1 Open the cover (**201**) and remove the printed circuit board cover (**Type plate**).
⇒ 4.4 Assembling/disassembling the cover on page 17
⇒ 4.6 Optional extras installation on page 21
- 2 Remove the jumper (**JP1**) from the motherboard (**110**).
- 3 Put the jumper (**JP1**) onto the plug-in bridge (**113**) for the printed circuit board for mA output signal.
- 4 Plug the printed circuit board for mA output signal (**111**) together with its pin strip into the plug-in bridge (**113**) on the motherboard (**110**).
- 5 Lock the spacers (**27**) into the holes in the motherboard.

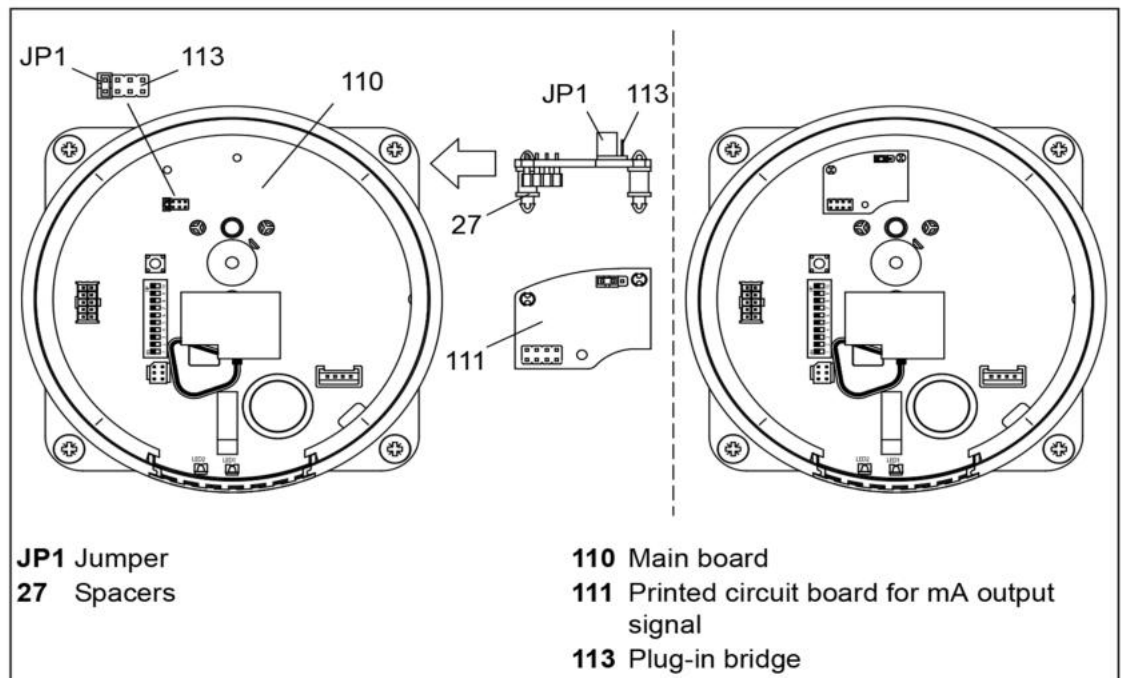

diagram 12 Installation of the printed circuit board for mA output signal

6 Select the output signal range with the jumper (**JP1**):

- Jumper right: 0 ... 20 mA
- Jumper left: 4 ... 20 mA

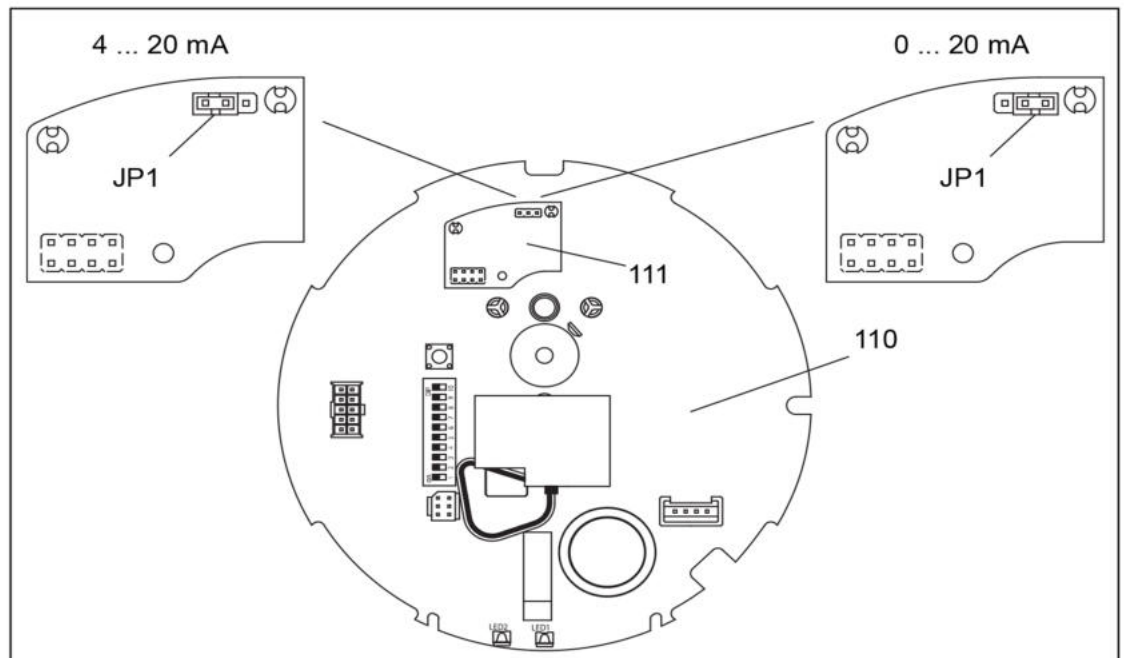

diagram 13 Set signal range for mA output signal X

5 Commissioning



Electric shock due to live components!

If the power supply is switched off, there is danger of electric shock due to live components.

- Prior to starting work ensure that the actuator is disconnected safely from the mains power supply.
- Secure against unauthorised switching-on.

The operating parameters are set **(116)** on the coding switches. The coding switches are located on the Main board **(110)**.

⇒ 4.4 *Assembling/disassembling the cover* on page 17

⇒ 4.6 *Optional extras installation* on page 21

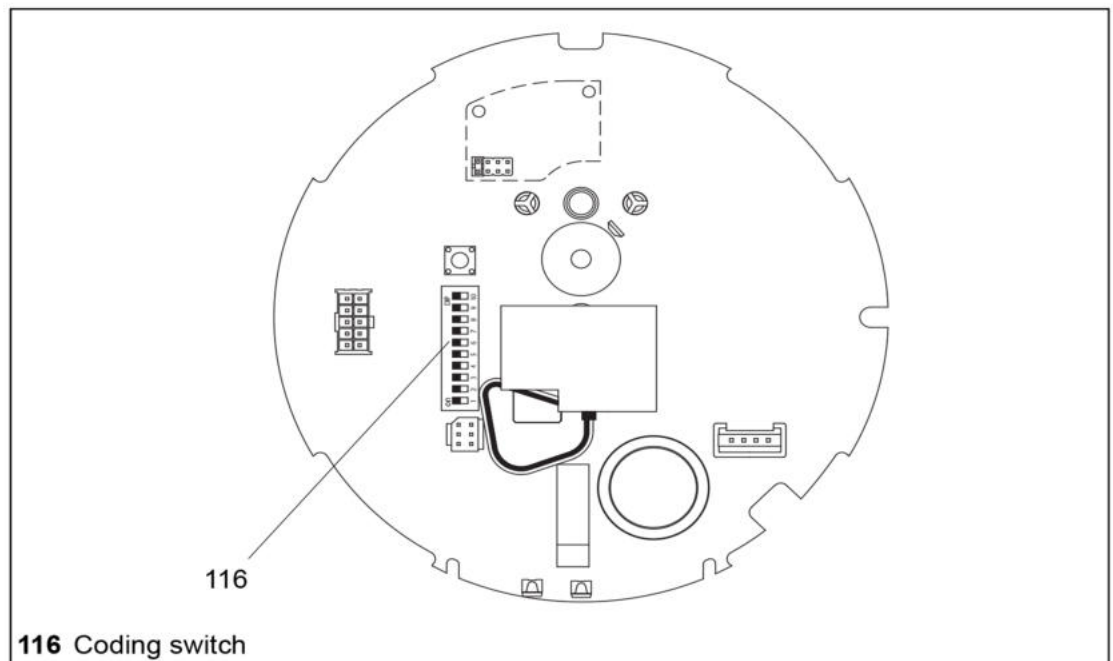

diagram 14 Printed circuit board cover and coding switches

5.1 Operating parameters and coding switch positions

The operating parameters must be set with the coding switches before the linear actuator can be operated.



Malfunctions due to incorrect switch position S1

Switch S1 must always be at "on".

- Ensure that switch S1 is at "on".

| Switch | on | off |
|--------|--|---|
| S1 | Ready for operation | - |
| S2 | X characteristic curve  | X characteristic curve  |
| S3 | Y characteristic curve  | Y characteristic curve  |
| S4 | Input signal (Y) 0 ... 10 V DC or 0 ... 20 mA | Input signal (Y) 2 ... 10 V DC or 4 ... 20 mA |
| S5 | Actuating time 2.5 s/mm | Actuating time 5 s/mm |
| S6 | Autotest and Autopause on | Autotest and Autopause off |
| S7 | Limit position for actuator spindle extended | Limit position for actuator spindle retracted |
| S8, S9 | The hysteresis (0.05 ... 0.5 V) is set using S8 and S9. | |
| S10 | Input signal (Y) in mA | Input signal (Y) in V |

Table 4 Coding switch positions

5.2 Set input signal

Diagram 15 Set input signal

 ⇒ Further information: *Input signal (Y)* on page 9

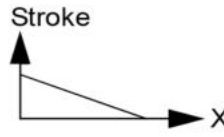
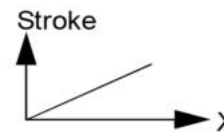
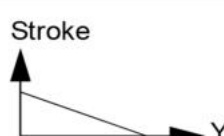
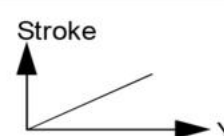
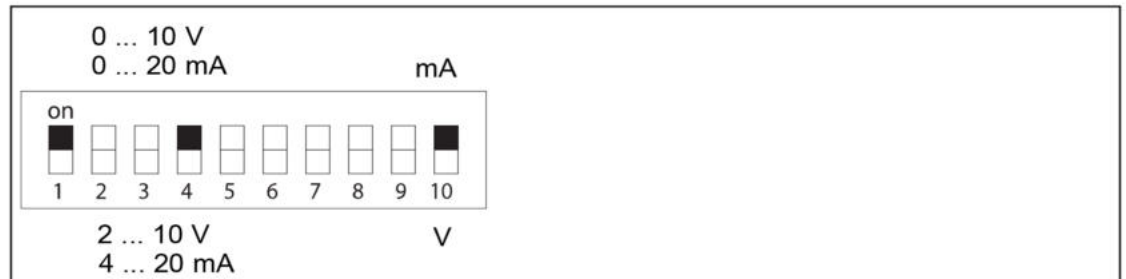
5.3 Set actuating time

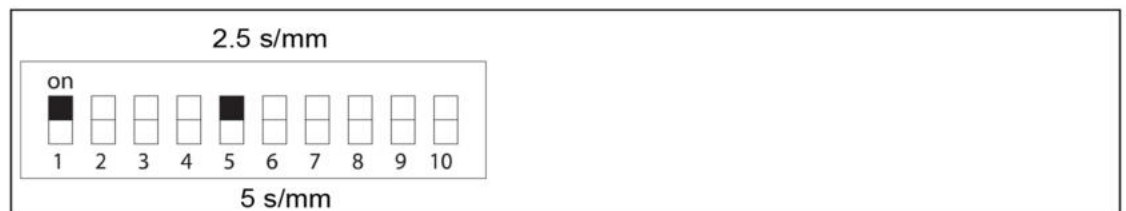
Diagram 16 Set actuating time

 ⇒ Further information: 2.4.5 *Set time* on page 10

5.4 Set hysteresis

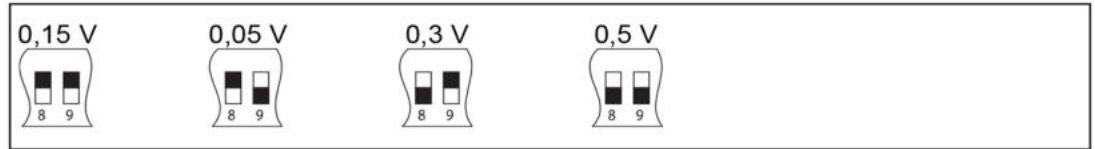

Diagram 17 Set hysteresis

⇒ For further information 2.4.6 *Hysteresis* on page 10

5.5 Set actuating direction

The actuating direction of the linear actuator can be reversed at the coding switch (inverted operation).

| Actuator position | Normal operation | Inverted operation (X and Y inverted) |
|-------------------|--|--|
| | Y = 10 V DC Y = 20 mA | Y = 0 V DC Y = 2 V DC Y = 0 mA Y = 4 mA |
| | Y = 0 V DC Y = 2 V DC Y = 0 mA Y = 4 mA | Y = 10 V DC Y = 20 mA |

Coding switch S2: X (output signal), coding switch S3: Y (input signal)

Table 5 Set actuating direction

5.6 Set Autotest and Autopause

If coding switch S6 is at ON, Autotest and Autopause are active.

Approaching the limit switch in rapid traverse is triggered approx. every 10 days in Autotest. A new zero balance is carried out automatically.

A 3-second pause (2-minute measuring cycle) is carried out in Autopause after more than 20 actuator commands in different directions per minute.

It is not possible to select these two functions separately.

5.7 Set limit position

Select the limit position for the linear actuator using coding switch S7:

- S7 ON: Limit position with extended spindle nut
- S7 OFF: Limit position with retracted spindle nut

The limit position is approached in the following situations:

- In the event of open-circuit detection by the Y signal (only for 2 ... 10 V DC or 4 ... 20 mA),
- In the event of a binary signal (circuit is broken between terminals B1 and B2),
- in Autotest,
- upon disruption of the power supply (manual adjustment).

5.8 Set potential-free way-switch

Set the two way-switches via trimmer potentiometers P1/P2 independently from one another. Carry out the specified working steps for each way-switch once.

■ Proceed as follows to set a way-switch:

- 1 Ensure that the linear actuator has been started up and initialised.

⇒ 5.10 Commissioning on page 30

⇒ 5.9 Initialising the path measuring system on page 29



Malfunction due to inaccurately set way-switch!

If the actuator has been set to Manual mode (without power supply), the way-switch can only be set inaccurately (Centre position of the arm corresponds to the switching point for approx. 50% lift in this instance).

- Switch the actuator to Automatic mode in order to set the way-switch accurately.

- 2 Move the actuator into a position where a switching event should be triggered. The following working steps must be carried out with the power supply switched on.



Electric shock due to live components!

Once the power supply has been switched on, there is risk of electric shock due to live components.

- Take care not to touch any live components.
- Take care not to cause a short circuit on a printed circuit board with the tool.

- 3 Open the cover **(201)**.
 ⇒ 4.4 Assembling/disassembling the cover on page 17
 The way-switch printed circuit board is located in the cover **(106)**.
- 4 Use a screwdriver to turn the trimmer potentiometer until the way-switch switches. The associated LED goes on or off during this operation.
 Use potentiometer P1 **(105 P1)** to set way-switch 1.
 LED 1 indicates the switching status.
 Use potentiometer P2 **(105 P2)** to set way-switch 2.
 LED 2 indicates the switching status.

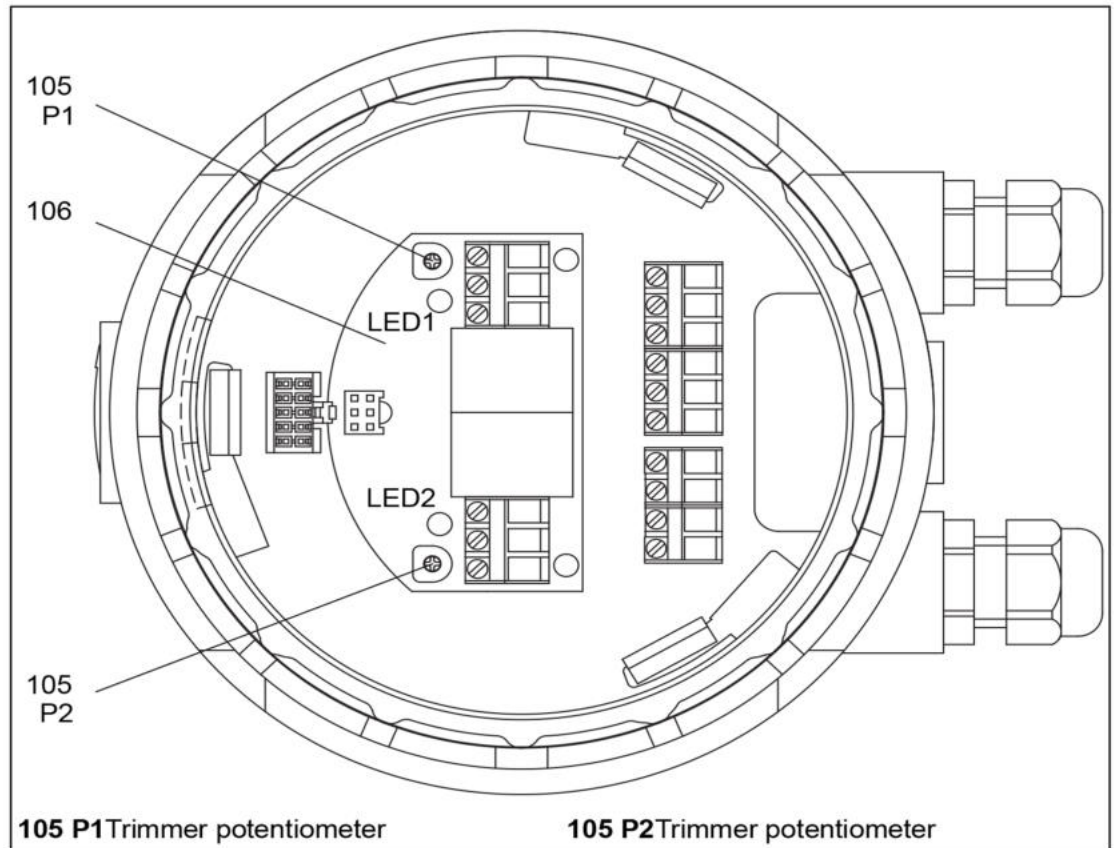

diagram 18 Way-switch printed circuit board in cover

- 5 Observe the permitted way-switch contact load:

| | |
|--------------------------|--------------------------------|
| Nominal load | 8 A, 250 V AC 8 A, 30 V DC |
| Switching voltage | max. 400 V AC max. 125 V DC |

Table 6 Way-switch contact load

- 6 Switch off the power supply to the actuator and connect the way-switch contacts.
- 7 Close the linear actuator **(201)** cover
 ⇒ How to attach the cover on page 17

5.9 Initialising the path measuring system



Linear actuator starts automatically!

The linear actuator starts immediately after being connected to the supply voltage and automatically moves to a reference point of the path measuring system.

- Wait until this reference point has been reached and the linear actuator has stopped.

The path measuring system has to be initialised after the following:

- At initial commissioning
- After repairs to the valve or actuator
- After a replacement of valve or actuator

Initialisation may be triggered in two different ways.

■ How to initialise via the initialising button



Risk of injury from electric shock by live parts!

When the supply voltage is turned on there is a risk of electric shock from live parts.

- Take care not to touch any live parts.
- Take care to apply the tool in a way that does not cause short-circuit.

- 1 Open the cover **(201)**.
⇒ 4.4 Assembling/disassembling the cover on page 17
- 2 Ensure that supply voltage is applied.
- 3 After applying the supply voltage the emergency actuating unit (NE) will automatically be tensed by the actuator. After tensing the actuator will remain in bottom limit position.
- 4 After a waiting period of c. 25 seconds push and hold the initialising button **(118)** for at least 2 seconds (stopping time). After the initialising cycle the actuator will follow the actuating signal.

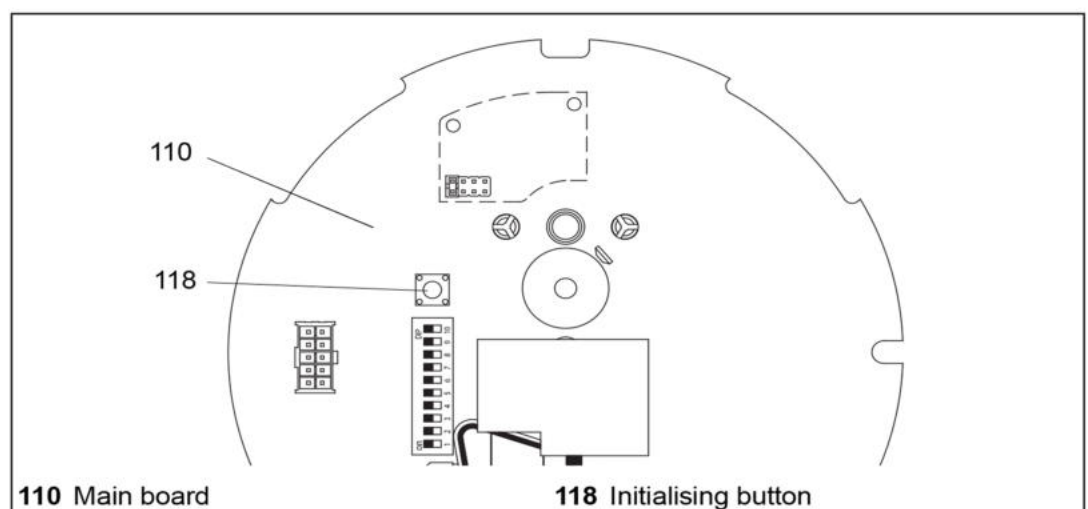

diagram 19 Initialising the path measuring system

■ **Proceed as follows to initialise via the connecting terminals**

- 1 Connect the power supply simultaneously to terminals 2 and 3. Ensure that the power supply remains on for at least 1 second.
⇒ *diagram 8* on page 19

5.10 Commissioning

- 1 Check that all installation and assembly tasks have been completed correctly.
⇒ *4 Assembly* on page 14
- 2 Ensure that the electric actuation of the linear actuator is ensured without danger to persons or equipment or the system.
- 3 Ensure that the linear actuator is correctly fixed and the linear actuator cover is closed.
⇒ *4.4 Assembling/disassembling the cover* on page 17
- 4 Ensure that the linear actuator is switched to Automatic mode.
⇒ *6.1 Changing between manual and automatic mode* on page 31
- 5 Ensure that the operating parameters have been correctly set.
⇒ *5.1 Operating parameters and coding switch positions* on page 24
- 6 Ensure that the path-measuring system has been initialised.
⇒ *5.9 Initialising the path measuring system* on page 29
- 7 Connect the power supply. Then the linear actuator moves to the reference point.
The linear actuator is ready for operation.

6 Operation

Prior to commissioning the linear actuator you will have to initialise it and select the operating mode.

⇒ 5 Commissioning on page 24

⇒ 5.9 Initialising the path measuring system on page 29

6.1 Changing between manual and automatic mode

It is possible to run the linear actuator in automatic mode or manual mode (manual adjustment). During manual mode you will only be able to change the lift when voltage is applied and the spring of the response unit is in a tensed state.

- In automatic mode the spindle nut moves to the position set by the controller.
- In manual mode it is possible to set the spindle manually, e. g. for control purposes. Output signal (X) is not available in manual mode.

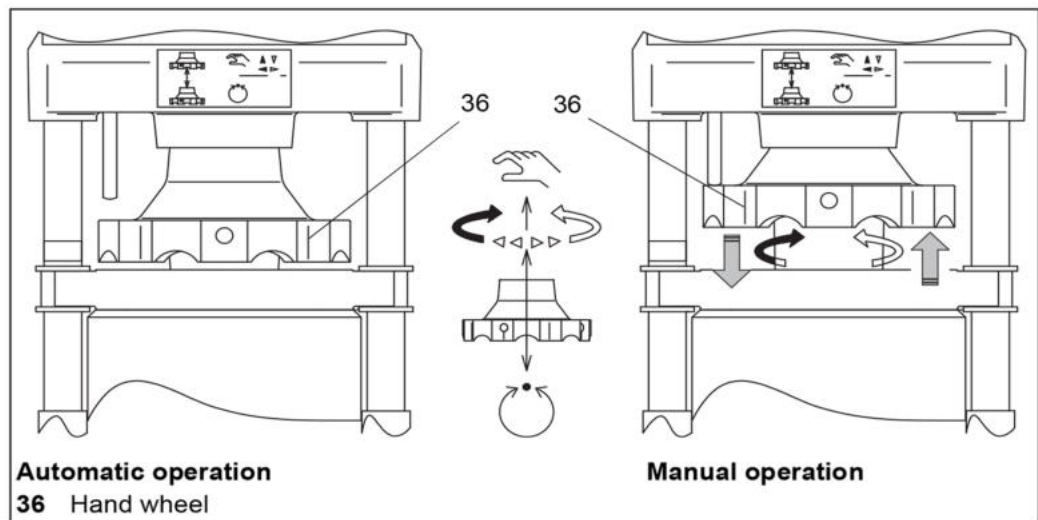

diagram 20 Selecting automatic mode

■ Proceed as follows to switch to Manual mode

- 1 Move the handwheel **(36)** into the manual mode position and rotate it until the handwheel locks.



Risk of damage to valve and actuator in Manual mode!

The valve can get damaged if it is pressed too firmly into its seat when closing in Manual mode.

- Do not rotate the handwheel any further if the amount of effort needs to be increased!
- Never use force.

- 2 Use the handwheel to rotate the spindle nut into the required position. Rotate the handwheel until the rotational resistance increases. Do not use force!

■ Proceeds as follows to switch to Automatic mode

- 1 Move the handwheel **(36)** into the automatic mode position.
- 2 The linear actuator moves first of all into the position specified by coding switch S7 and then into the position specified by the control.

6.2 LED display

The LEDs in the viewing window **(60)** indicate operating states or faults.

⇒ 10.2 Operating faults checklist on page 34

















| Green LED | Operating status / fault |
|---|---|
|  duration | Normal operation, standby The LED illuminates continuously, actuator awaits drive command. |
|     0,5s 0,5s 0,5s 0,5s | Standard Operation Actuator carries out drive command. |
|     0,2s 1,5s 0,2s 1,5s Short - long rhythm | Open-circuit detection In operating modes 2 ... 10 V DC or 4 ... 20 mA, the input signal has dropped below 1 V or below 2 mA. ⇒ 2.4.4 Open-circuit detection on page 10 |
|     2,5s 2,5s 2,5s 2,5s Long - long rhythm | Lock detection (only in Continuous mode) The linear actuator is mechanically locked. ⇒ 2.4.2 Lock detection on page 9 |
|     1,5s 0,2s 1,5s 0,2s Long - short rhythm | Continuous signal on terminals 2 and 3 An initialisation run starts in the event of simultaneous control signal on terminals 2 and 3 (max. 4 attempts). The linear actuator switches off automatically after 4 failed attempts. |

Table 7 Green LED display







| Red LED | Operating status / fault |
|---|---|
|  OFF | Temperature within normal range |
|  duration | Heating operation ⇒ Actuator heating on page 10 |
|     0,25s 0,25s 0,25s 0,25s Flashes regularly | Actuator overheats ⇒ Overheating protection on page 9 |

Table 8 Red LED display

7 Maintenance, Care and Repairs

The linear actuator is low-maintenance. No routine or periodic maintenance is required.

8 Spare parts

Check the data on the linear actuator rating plate when ordering optional extras or spare parts. The data on the rating plate is decisive for linear actuator technical data and mains power supply requirements.



Equipment damage due to defective spare parts!

Spare parts must comply with the technical requirements specified by the manufacturer.

- Use only original spare parts.

⇒ 2.1 Components on page 7

⇒ 2.2 Accessories on page 8

9 Shutdown and Disposal

Dispose of the linear actuator in accordance with national regulations and legislation.

10 Troubleshooting

The path-measuring system needs to be re-initialised after troubleshooting.

⇒ 5.9 Initialising the path measuring system on page 29

10.1 Troubleshooting

If the linear actuator does not work perfectly, proceed as follows to eliminate the fault:

- 1** Check that the linear actuator was installed correctly.
- 2** Check the linear actuator settings and the rating plate data.
- 3** Eliminate the faults using the checklist.
⇒ 10.2 Operating faults checklist on page 34
- 4** If this fault still cannot be eliminated, contact the manufacturer.
- 5** Please quote the following for all queries and returning goods to the manufacturer:
 - F-No. (Fabrication No. = Contract No.)
 - Type designation
 - Power supply and frequency
 - Additional equipment
 - Error report
- 6** If the fault cannot be eliminated by the inquiry, the equipment can be returned to the manufacturer.

10.2 Operating faults checklist

| Fault | Cause/reason | Remedy |
|---|---|--|
| 1. Linear actuator does not work. | Handwheel (36) is in manual mode position | <input type="checkbox"/> Switch handwheel to automatic mode position. |
| | Mains power failure | <input type="checkbox"/> Establish cause and eliminate. |
| | Fuse defective. (in the electrical cabinet) | <input type="checkbox"/> Establish cause and eliminate, change fuse. |
| | Linear actuator incorrectly connected | <input type="checkbox"/> Rectify connection in accordance with circuit diagram (on the cover). |
| | Short circuit due to humidity | <input type="checkbox"/> Establish cause, dry the linear actuator, change hood seal and screw connections if necessary ad/or fit protective hood. |
| | Short circuit due to incorrect connection | <input type="checkbox"/> Rectify connection |
| | Motor has coil damage (burnt out) <ul style="list-style-type: none"> • e.g. due to too high voltage • Electronic system defective | <input type="checkbox"/> Establish cause, measure current data Compare with rating plate and table, Remove linear actuator and return to manufacturer for repair. |
| 2. Linear actuator runs in an unstable manner, i. e. switches between clockwise and counter-clockwise rotation. | Voltage drop due to too long connecting cables and/or too small cross-section. | <input type="checkbox"/> Measure linear actuator current data, recalculate and change connecting cables if necessary. |
| | Mains power fluctuations greater than permissible tolerance ⇒ 2.5 <i>Technical data</i> on page 12 | <input type="checkbox"/> Improve mains power ratios |
| 3. Linear actuator cuts out from time to time or initialises frequently. | Supply cable has loose contact | <input type="checkbox"/> Check and tighten connections (terminal strips) |
| 4. Linear actuator does not move to the limit positions. Valve does not close/open. | Valve jams | <input type="checkbox"/> Ensure smooth running valve |
| | Too high system pressure | <input type="checkbox"/> Correct system pressure |
| 5. Linear actuator does not move or does not move correctly to the position specified by input signal Y. | Input signal Y faulty: <ul style="list-style-type: none"> • Error signals • Signal fluctuations | <input type="checkbox"/> Check input signal Y on linear actuator, eliminate cause of fault |
| | Motherboard faulty | <input type="checkbox"/> Change motherboard, remove linear actuator and return to manufacturer for repair if necessary. |
| 6. Green LED flashes in long / long rhythm | Lock detection has responded | <input type="checkbox"/> Press INIT and observe actuator during initialisation. <input type="checkbox"/> Check valve for smooth running over entire lift range. |
| 7. Green LED flashes in short / long rhythm | Open circuit detected | <input type="checkbox"/> Measure reference value voltage or current on linear actuator. |
| 8. Green LED flashes in long / short rhythm | Relay contact adherence | <input type="checkbox"/> Check control |
| 9. Red LED flashes regularly | Actuator overheats | <input type="checkbox"/> Motor has switched off automatically. Automatic start-up after cooling down |

table 9 Operating faults checklist