

Operating Manual

Linear actuators

MLH400C • MLH400A • MLH403C • MLH403A

General information

Amendment	Version	Date	Modifications
	1.0	Mai 2006	Initial preparation
	2.0	July 2007	Complete revision and amendment
	2.1	July 2009	Amendment MC400
	2.2	March 2011	Revision

Copyright The copyright for this operating manual as well as all rights in case of patent awarding or registration of registered design remains with the manufacturer!

Subject to alteration The regulations, directives, standards etc. are compliant with the current state of information at the time of development and are not subject to modification service. They must be applied by the operator at his own responsibility in their latest valid version.

Concerning all data, information, and illustrations in this manual we reserve the right of technical modifications and improvements. No claims can be considered for alteration or rework of already delivered lift drives.

Table of contents

1 Safety	4	4 Assembly	12
1.1 Proper use	4	4.1 Checking the scope of delivery	12
1.2 Information for the operator	4	4.2 Preparing assembly	12
1.3 Personnel.....	5	4.3 Mount linear actuator on valve	13
1.4 Prior to starting work.....	5	4.4 Assembling/disassembling the cover.....	14
1.5 During operation	5	4.5 Electrical connection	15
1.6 Working environment.....	5	4.5.1 Controller independent circuit	17
		4.5.2 Removing the PCB cover	18
2 Product Specification	6	4.6 Fitting accessories	18
2.1 Component parts	6	4.6.1 Fitting a PCB for a path switch	19
2.2 Accessories	7	4.6.2 Fitting the PCB for the mA output signal.....	20
2.3 Operating modes	7	5 Commissioning	22
2.3.1 Continuous mode	7	5.1 Operating parameters and encoding	
2.3.2 Three-point mode	8	switch settings.....	22
2.4 Functions	8	5.2 Setting the input signal.....	23
2.4.1 Binary signal / frost protection function.....	8	5.3 Setting the actuating time.....	23
2.4.2 Blockage detection	8	5.4 Setting the hysteresis.....	24
2.4.3 Internal temperature control	8	5.5 Setting the actuating direction.....	24
2.4.4 Wire break detection.....	9	5.6 Setting auto test and auto pause	24
2.4.5 Actuating time.....	9	5.7 Setting the limit position	25
2.4.6 Hysteresis.....	9	5.8 Setting a potential-free path switch.....	25
2.4.7 Manual mode and response signal.....	9	5.9 Initialising the path measuring system	27
2.4.8 Auto test	10	5.10 Commissioning.....	28
2.4.9 Auto pause	10	6 Operation	29
2.4.10 Potential-free limit switch (accessory)	10	6.1 Changing between manual and automatic mode...29	
2.5 Technical data	10	6.2 LED display	30
2.6 Type plate	11	7 Maintenance, care and repairs	30
3 Transportation & Storage	11	8 Spare parts	30
		9 Decommissioning and disposal	31
		10 Removal of faults	31
		10.1 How to remedy faults	31
		10.2 Check list for breakdown.....	32

1 Safety

Read these Operating Instructions carefully particularly the following safety instructions prior to installation and operation.



DANGER

Directly threatening hazard leading to death or serious physical injuries.



WARNING

Potentially hazardous situation which may lead to death or serious physical injuries.



CAUTION

Potentially hazardous situation which could lead to minor physical injuries. Indicates a hazard which may cause material damage.



ATTENTION

Potentially hazardous situation where the product or an object in its environment may get damaged.

Hint: Utilisation instructions and other useful information.

1.1 Proper use

Linear actuators MLH400C - MLH400A - MLH403C - MLH403A are controlled by three-point control or constant control. Linear actuators in the series described in these Operating Instructions are used for valve stroke adjustment.

Concurrence of the above type designation with the linear actuator rating plate must be checked prior to starting any operations in order to guarantee utilisation in accordance with specification. The data on the rating plate is decisive for linear actuator technical data and mains power supply requirements.

Any utilisation for tasks other than the aforementioned usage in accordance with specification and operating with mains power supply ratios other than those permitted is not deemed to be utilisation in accordance with specification. The operator bears sole liability for the risk to persons and machine and other assets in the event of utilisation not in accordance with specification.

The intended use also includes the compliance with accident preventions, DIN VDE regulations and safe working practices for all measures described in these operating instructions in due consideration of prevailing rules.

1.2 Information for the operator

Always keep the Operating Instructions available at the linear actuator deployment site.

Observe the current health and safety, accident prevention and DIN VDE standards for installation, operation and maintenance.

Take into consideration any additional regional, local or in-house safety regulations.

Ensure that every person entrusted with one of the tasks specified in these Operating Instructions has read and understood these instructions.

1.3 Personnel

Only qualified personnel may work on these linear actuators or in their vicinity. Qualified persons are those persons entrusted with installation, assembly, commissioning and operation or maintenance of the linear actuators and possessing the appropriate qualifications for their activity. The necessary and prescribed qualifications include:

- Training / instruction or authorization to turn on /off circuits and appliances / systems according to EN 60204 (DIN VDE 0100 / 0113) and the standards of safety technology.
- Training or instruction according to the standards of the safety technology concerning care and use of adequate safety and work protection equipment.
- First Aid training.

Work in a safe manner and refrain from any working practice which endangers the safety of persons or damages the linear actuator or other assets in any way whatsoever.

1.4 Prior to starting work

Prior to starting any work, check that the type designations specified here concur with the data on the linear actuator rating plate.

Linear actuators MLH400C, MLH400A, MLH403C, MLH403A.

1.5 During operation

Safe operation is only possible if transportation, storage, installation, operation and maintenance are carried out safely and materially and professionally correctly.

Transportation, installation and assembly

Observe the general set-up and safety regulations for heating, ventilation, air-conditioning and pipework design. Use tools correctly. Wear the necessary personal and other safety equipment.

Repairs and maintenance

Ensure that qualified personnel switch off the linear actuator prior to maintenance or repair work in accordance with DIN VDE.

1.6 Working environment

Read the data concerning the working environment in the Technical Data.

2 Product Specification

The linear actuators control a stepper motor by means of a micro controller. The stepper motor's rotational movement is converted into a linear movement via planetary gears and a threaded spindle with spindle nut.

2.1 Component parts

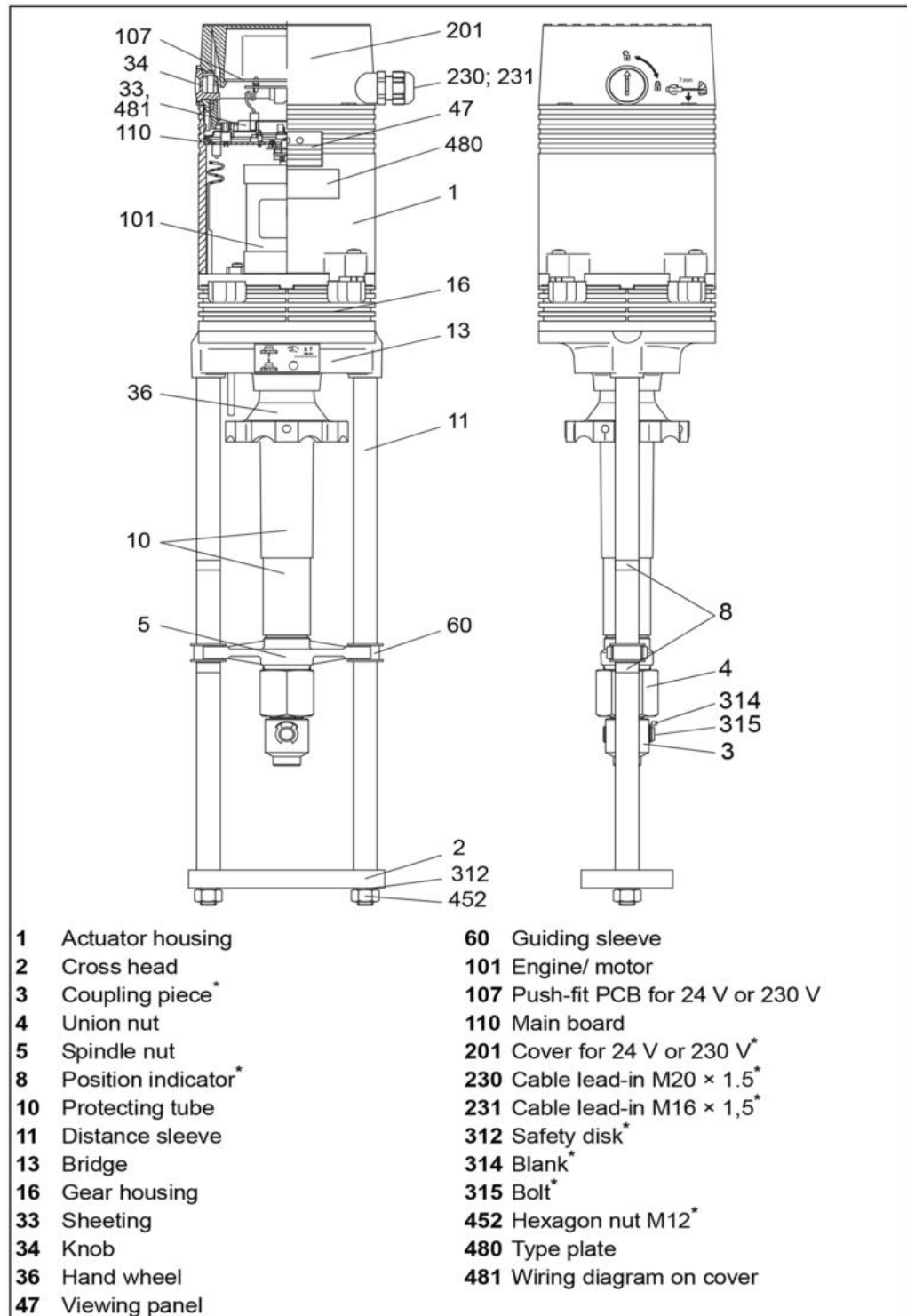
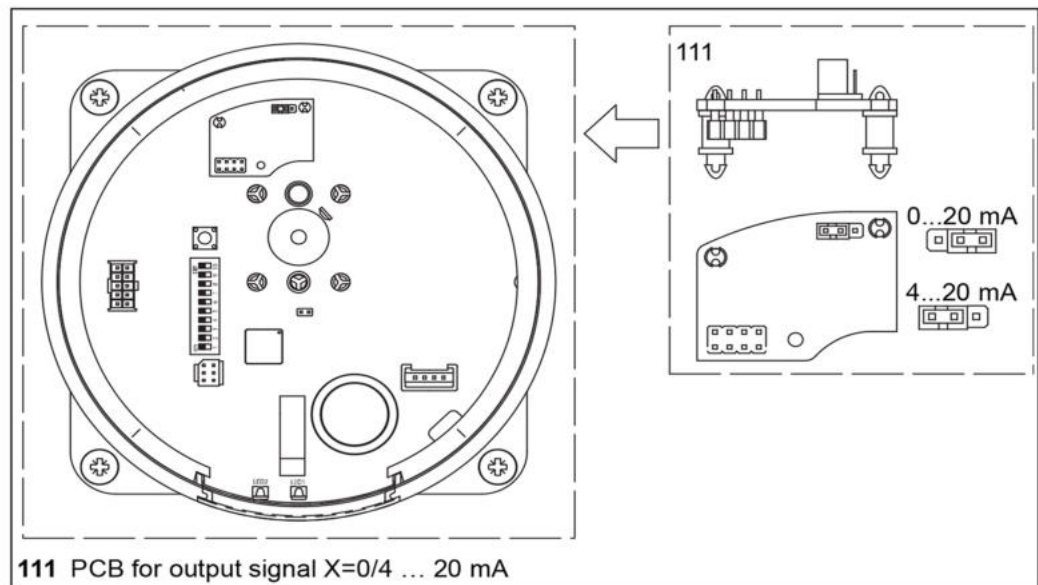

diagram 1 Component part denominations

* This component part is available as a spare part!

2.2 Accessories



111 PCB for output signal X=0/4 ... 20 mA

diagram 2 PCB for mA-output signal on main PCB

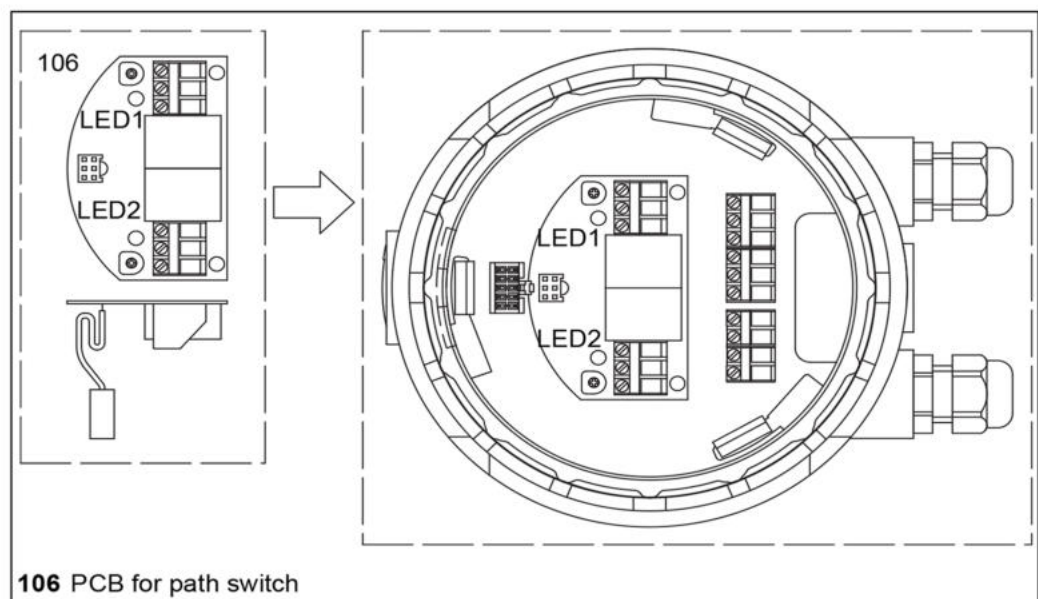

106 PCB for path switch

diagram 3 Position switch PCB in cover

2.3 Operating modes

The linear actuator can be operated manually or automatically.

- In manual mode stroke is adjusted via the hand wheel.
- In automatic mode stroke is controlled electrically.

2.3.1 Continuous mode

In continuous mode the system control presets the position of the linear actuator whilst inside the linear actuator the input signal (Y) of the system control is continuously compared with the output signal (X) of the linear actuator. In doing so the output signal depends on the position of the linear actuator (travel).

The linear actuator keeps moving until the input signal and the output signal match.

Input signal (Y) The input signal (Y) of the system control specifies the desired position for the linear actuator. It is applied in the form of an analogue signal to terminal Y.

Possible input signals:

- 0 ... 10 V DC / 2 ... 10 V DC
- 0 ... 20 mA / 4 ... 20 mA

Output signal (X) The output signal (X) determines the actual position of the linear actuator. It is applied to terminal X in the form of an analogue signal.

0% to 100% valve lift is put out as:

- 0 ... 10 V DC
- 0 ... 20 mA or 4 ... 20 mA (accessory PCB for output signal **(111)**)

2.3.2 Three-point mode

The direction of rotation is set via the control voltage at terminal 2 and terminal 3 on the main PCB:

- When the control voltage is applied to terminal 2, the spindle nut will be extended.
- When the control voltage is applied to terminal 3, the spindle nut will be retracted.

2.4 Functions

2.4.1 Binary signal / frost protection function

The terminals B1 and B2 on the main PCB are bridged during normal operation. If the electric circuit between B1 and B2 is interrupted, the linear actuator will store the current position and afterwards move automatically to its limit position.

All other control signals will be ignored during this process.

The linear actuator will remain in limit position until the electric circuit between B1 and B2 has closed.

- In three-point mode the linear actuator will automatically return to the stored position.
- In continuous mode the desired value of the input signal will be restarted.

2.4.2 Blockage detection

If the linear actuator is blocked manually, the linear actuator will briefly move back and then retry to reach the required position. If this is still unsuccessful after a total of 7 attempts the linear actuator will be turned off in order to prevent damage to the linear actuator and the control element.

A blockage detection is indicated by the green LED on the viewing panel **(47)**.

⇒ *table 7* on page 30

2.4.3 Internal temperature control

The actuator has an internal temperature control system.

Overheating protection When the temperature inside the actuator housing exceeds a certain limit the motor will be turned off. After the motor has cooled down it will be automatically restarted.

Actuator heating When the temperature inside the actuator drops below 15 °C the motor will be switched to act as heating unit during stoppages. The actuator heating will automatically switch off at a continuous temperature of c. 22 °C. The actuator heating does not affect the functions of the actuator.

Heating capacity:

- 12.5 W for temperatures from c. 8 °C to c. 15 °C
- 18 W for temperatures under 8 °C

Heating the actuator prevents the formation of condensation inside the actuator and ensures the ease of movement for the gears even at temperatures up to c. - 10°C.

Heating operation and motor stoppage are displayed by the red LED on the viewing panel. **(47)**

⇒ *table 8 Display red LED on page 30*

2.4.4 Wire break detection

Wire break detection is only available for continuous mode with an input signal 2 ... 10 V DC and 4 ... 20 mA.

When the input signal drops below 1 V or 2 mA during continuous mode, the linear actuator will move to the limit position set by encoding switch 7.

Wire break detection is displayed by the green LED on the viewing panel **(47)**.

⇒ *table 7 Display green LED on page 30*

2.4.5 Actuating time

The time required for the spindle nut to travel a defined distance is called actuating time. Actuating time is specified in s/mm. Encoding switch S5 is used to set the actuating force.

⇒ *5.3 Setting the actuating time on page 23*

2.4.6 Hysteresis

Hysteresis equals the difference of the input signal (Y) that is required after a reversal of signal direction in order to move the spindle nut.

It serves to prevent permanent oscillation of the actuator motor around a certain hoisting position during minor input signal alterations.

⇒ *5.4 Setting the hysteresis on page 24*

2.4.7 Manual mode and response signal

In manual mode it is possible to change the stroke without supply voltage.

- Motor and control electronics are turned off in manual mode to make hoisting movements of the control impossible.
- The moment you set the linear actuator to manual mode the control switches a signal to terminal R, provided supply voltage is applied.

⇒ *6.1 Changing between manual and automatic mode on page 29*

2.4.8 Auto test

If a valve is not actuated for a long time the valve cone may get stuck. The auto test function acts as a preventative measure. When you start the auto test function for the linear actuator the linear actuator will after c. 10 days of inactivity move in rapid traverse mode to the limit position set by encoding switch S 7 and then return to the initial position.

⇒ 5.6 *Setting auto test and auto pause* on page 24

2.4.9 Auto pause

This function is used by the actuator to count the traverse commands per minute that involve a change of direction. If there are more than 20 direction varying traverse commands per minute this will result in a compulsory pause of 3 s.

⇒ 5.6 *Setting auto test and auto pause* on page 24

2.4.10 Potential-free limit switch (accessory)

The optional path switch PCB allows you **(106)** to set two actuating positions within which a potential-free contact is opened or closed.

⇒ 5.8 *Setting a potential-free path switch* on page 25

2.5 Technical data

Type	MLH400C MLH403C	MLH400A MLH403A
Supply voltage:	24 V AC ± 10% 24 V DC ± 10%	115 V AC ± 10% 230 V AC + 6% -10%
Power consumption	max. 50 VA	max. 63 VA
Weight	9.2 kg	9.6 kg
Dimensions	See technical data sheets	
Stroke	max. 60 mm	max. 60 mm
Frequency	50/60 Hz ± 5%	50/60 Hz ± 5%
Ambient temperature/ mode of operation	-10 to +50°C / S3 - 40 % ED -10 to +60°C / S3 - 30 % ED	
Enclosure protection	IP 54	IP 54
Actuating time	0.4 or 0.6 s/mm	0.4 or 0.6 s/mm
Actuating force	4.0 kN During 24 V DC the specified actuating force can only be reached with the help of an aligned AC voltage.	

table 1 Technical data

Input signal Y/ Resistance of load	<ul style="list-style-type: none"> • 0 ... 10 V DC / 77 kΩ • 2 ... 10 V DC / 77 kΩ • 0 ... 20 mA / 510 Ω • 4 ... 20 mA / 510 Ω
Output signal X/ Load rating	<ul style="list-style-type: none"> • 0 ... 10 V DC / resistance of load \geq 1200 Ω, I_{max}. 8 mA • 0 ... 20 mA / resistance of load \leq 500 Ω - with accessory PCB for output signal (111) • 4 ... 20 mA / resistance of load \leq 500 Ω - with accessory PCB for output signal (111)
Response signal R/ load rating	<ul style="list-style-type: none"> • 24 V DC / minimum impedance \geq 480 Ω / I_{max}. 35 mA
Cable impedance between B1 and B2	<ul style="list-style-type: none"> • max. 10 Ω

table 2 Technical data signals

2.6 Type plate

The type plate is attached to the housing of the linear actuator.

It bears the type denomination, serial number (s/no) and date of manufacture (last four digits).

⇒ 2.1 Component parts on page 6

		
MLH403A		
F.-Nr.: 07204142/01/0607		
AC 50 Hz 230 V	max. 63 VA	4 kN
Y=0...10 V DC	IP 54	0,4 s/mm
X=0...10 V DC	S3-50% ED	Stroke 60 mm

diagram 4 Example of type plate

3 Transportation & Storage



Non-compliance with safety regulations may result in injury!

- Wear the required personal and other safety equipment.
- Avoid impacts, blows, vibrations etc. to the linear actuator.
- Store the linear actuator (and, where appropriate, the entire controlling device) in a dry place.
- Keep to the specified transport and storage temperatures between -20 to +65°C.

4 Assembly

Prior to assembling the linear actuator:

⇒ 4.1 *Checking the scope of delivery* on page 12

⇒ 4.2 *Preparing assembly* on page 12

The following sequence of operations is part of the linear actuator assembly:

⇒ 4.3 *Mount linear actuator on valve* on page 13

⇒ 4.4 *Assembling/disassembling the cover* on page 14

⇒ 4.5 *Electrical connection* on page 15

4.1 Checking the scope of delivery

- 1 Check the packaging for damage.
- 2 Dispose of packaging in an environmentally friendly manner.
- 3 Check the delivered items against the delivery note in order to see whether the delivery is complete.
- 4 Report any missing or damaged products to the manufacturer.

4.2 Preparing assembly



A non-attached valve causes damage!

If you operate the linear actuator without valve, the spindle nut may fall off due to the missing stop.

- Always operate the linear actuator with a valve attached.

- 1 Allow for about 200 mm space above the cover at the site of installation.
- 2 Check the working environment before assembling and commissioning the linear actuator:
- 3 Ensure that the valve is correctly fitted. For details please see assembly instructions for valve.
- 4 Determine the assembly position of the linear actuator. Do not arrange linear actuators in a hanging position.

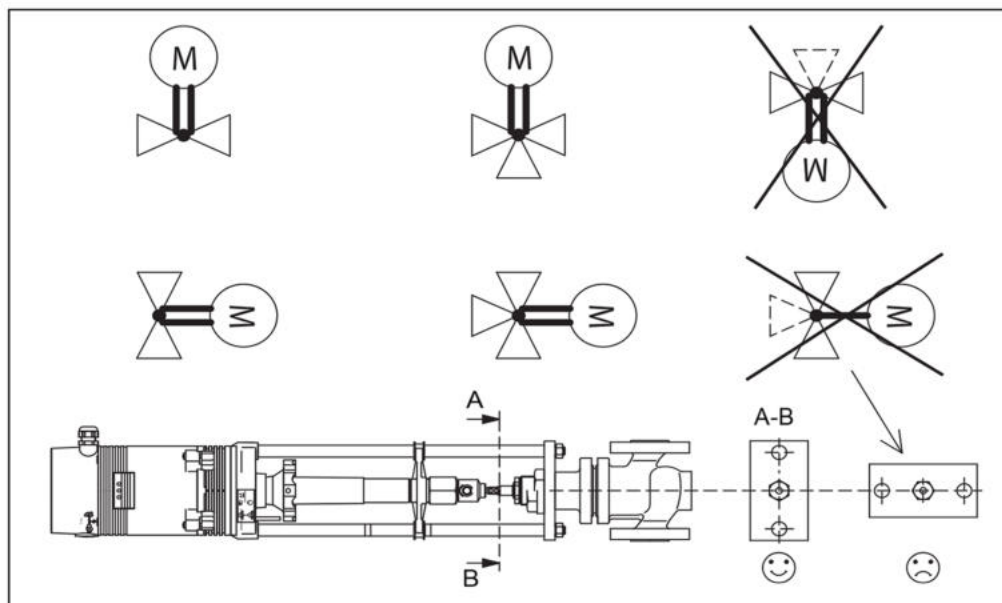

Diagram 5 Assembly positions for linear actuator and valve

4.3 Mount linear actuator on valve

If the linear actuator and the valve are delivered separately, the linear actuator must then be mounted on the valve.

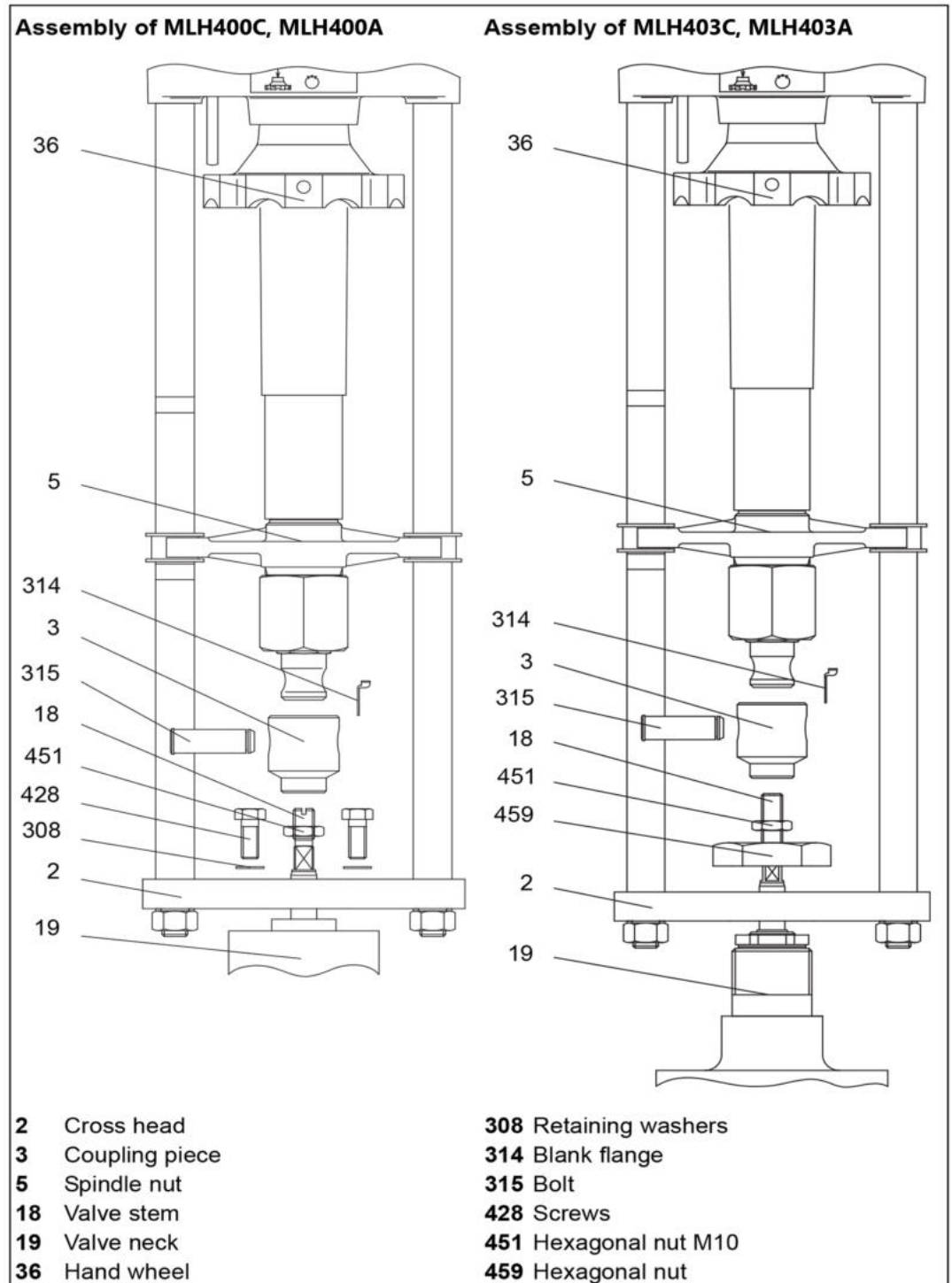

Diagram 6 Mount linear actuator on valve

■ **Proceed as follows to install the linear actuator:**

- 1** Remove the blank (**314**) flange.
⇒ *Diagram 6* on page 13
- 2** Remove the bolt (**315**) from the coupling (**3**) or force it out.

- 3 Rotate the hexagonal nut M10 (451) wrench size 17 onto the valve spindle (18).
 - 4 Rotate the coupling (3) onto the valve spindle (18).
 - 5 Use the flat hexagonal nut to lock the valve spindle (18) to secure it against distortion.
 - 6 Place the actuator with traverse (2) onto the valve neck (19).
 - 7 **For Types MLH403 :**
Fix the traverse (2) with a hexagonal nut (459) wrench size 50.
 - 8 **For Types MLH400 :**
Fix the traverse (2) of the actuator with screws (428) wrench size 13 and retaining washers (308) on the valve neck (19).
 - 9 Use the handwheel (36) to adjust the spindle nut (5) upwards so that the bolt(315) can be refitted.
 - 10 Fit the blank (314) flange!
- **Proceed as follows to dismantle the linear actuator:**
- 1 Carry out the installation sequence steps in reverse order.

4.4 Assembling/disassembling the cover

The cover contains the terminals for electric connection.



Risk of injury from electric shock by live parts!

When the power supply is on there is a danger of electric shock due to live parts.

- Prior to commencing any work, ensure that the actuator is safely disconnected from the power supply system.
- Secure against unauthorised restarting.
- Remove the cover only momentarily.

■ **How to remove the cover**

- 1 Unlock the cover (201). To this end use a screwdriver to turn the knob (34) anti-clockwise by 90° up to the stop pin.

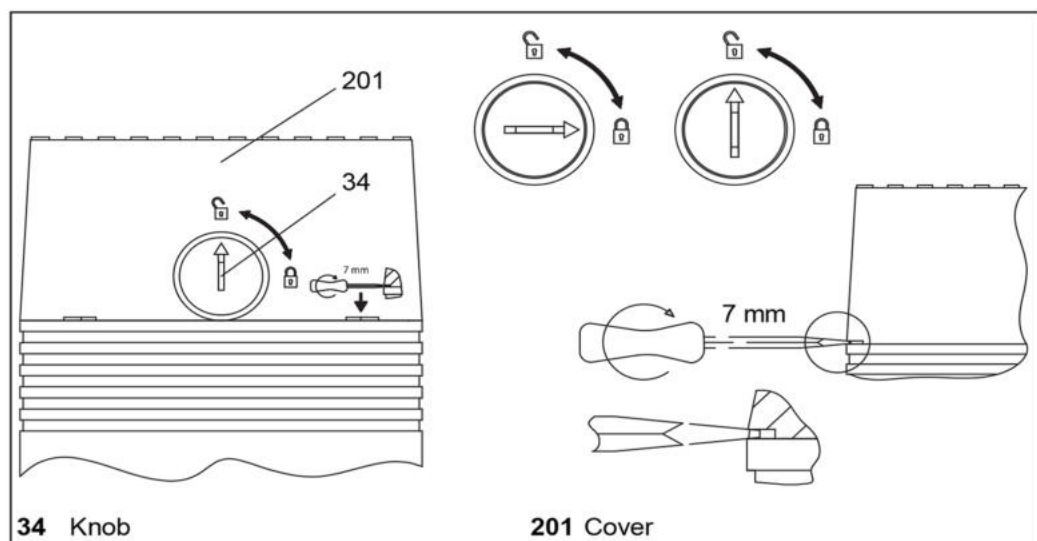

diagram 7 Removing the cover

- 2 Put a screwdriver into one of the notches and lift the cover (201).



Damaged cables result in damage to devices!

When lifting the cover you may tear off or damage the cabling inside the cover.

- Carefully remove the cover.

- 3 Remove the cover **(201)** carefully.
- 4 Disconnect the plug-in connection between the main PCB and the **(110)** cover **(201)**.

■ How to attach the cover

- 1 Plug the previously pulled off cables back into the main PCB **(110)**.
Pay attention to the notches on plug and socket.

Hint: You can mount the cover **(201)** in four, different, positions each of which is transposed by 90°. This allows the best possible laying of the connecting cable for different installations of the linear actuator.

- 2 Place the cover **(201)** on top and push it down to make it fit by applying moderate force.
- 3 Check the cover for correct fit to ensure air-tightness for the actuator housing.
- 4 Lock the cover **(201)**. To this end turn the knob, **(34)** with the help of a screwdriver by 90° right up to the stop pin.

4.5 Electrical connection



Danger of life caused by incompetent staff!

Electrical connections carried out by unqualified staff may result in death, severe bodily injury or considerable material damage.

- Make sure that such all work is carried out by qualified staff.

⇒ 1.3 Personnel on page 5



Risk of injury from electric shock by live parts!

When the supply voltage is turned on there is a risk of electric shock from live parts.

- Prior to commencing any work, ensure that the actuator is safely disconnected from the power supply system.
- Secure against unauthorised restarting.

■ How to prepare the electric connection

- 1 Ensure that the supply voltage matches the specifications on the type plate of the linear actuator.
- 2 To avoid breakdown, construct the line diameter according to actuating performance and required line length.
- 3 Lay the mains for a supply voltage of > 48 V separate from the signal and control wires.

When laying cables in a joint cable duct, use shielded control wires.

- 4 Check the supply voltage.
If the required tolerance is not achieved by a power transformer you will have to use an AC voltage stabilizer.
⇒ 2.5 Technical data on page 10

■ **How to establish electrical connection**

- 1 Remove the cover (201).
⇒ How to remove the cover on page 14
- 2 Run the cable through the screw joint in the cover to the terminal.
- 3 Connect the power supply according to the wiring diagram.
⇒ diagram 8 on page 16

Hint: The wiring diagram (481) is on the PCB cover(33).



Malfunctions caused by incorrect zero potential!

If the electric power supply for the linear actuator is fed by transducing sensors with varying zero potentials this may result in incorrect automatic controller action.

- Ensure that the zero potential is properly applied.

⇒ table 3 on page 17

- 4 Tighten the screw joints.

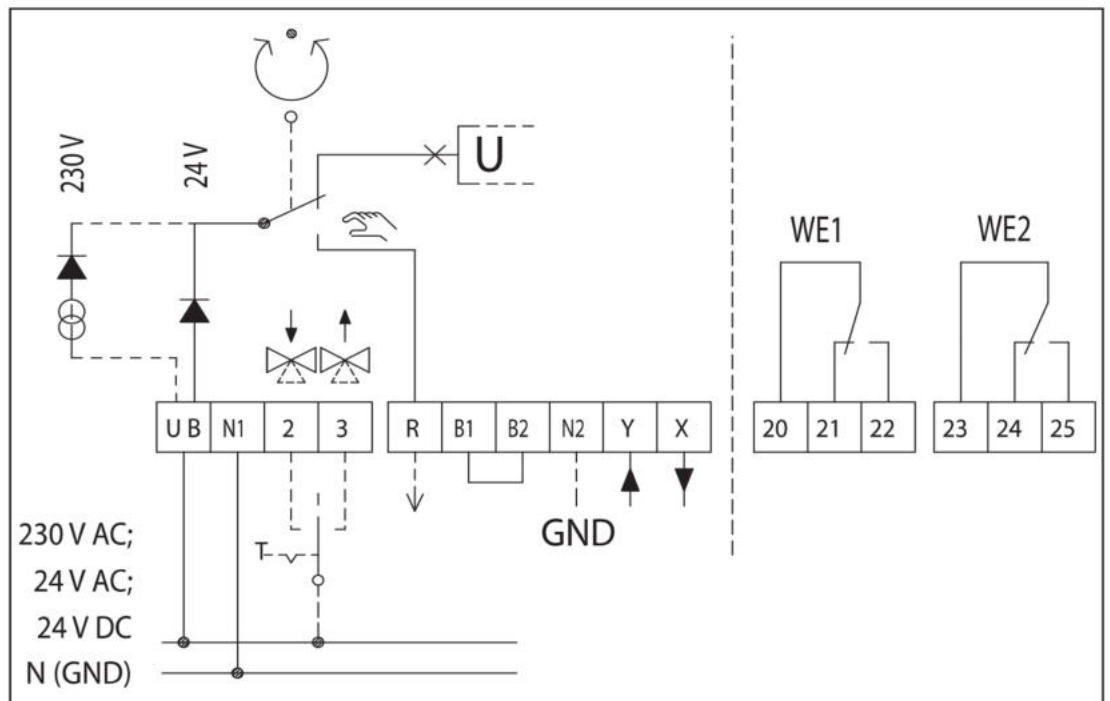

diagram 8 Circuit diagram

Terminal	Description
UB, N1	Supply voltage:
2	Control voltage for downward movement during three-point mode
3	Control voltage for upward movement during three-point mode
R	Response signal during “manual” mode • R= 24 V DC max. 35 mA
B1, B2	Binary input / frost protection function
N2	Zero potential of signals X, Y and R • When the zero potentials of signals X, Y and R are identical to the zero potential of the supply voltage it is possible to bridge terminals N1 and N2. • If you run the actuator in continuous mode at 230 V you will have to connect N2. • If you run the actuator in three-point mode at 230 V you will have to connect N2 if you wish to use X or R at the same time.
Y	Input signal continuous mode
X	Output signal continuous mode
20, 21, 22	Terminals path switch unit PS1
23, 24, 25	Terminals path switch unit PS2

table 3 Key to wiring diagram

4.5.1 Controller independent circuit

When working with 24 V supply voltage and 0 ... 10 V DC / 2 ... 10 V DC input signal you can switch the actuator controller-independently via a three-step toggle switch in the control cabinet.

■ How to switch the actuator controller-independently

- 1 Run the supply voltage 24 V AC via a diode and a three-step toggle switch to terminal Y.

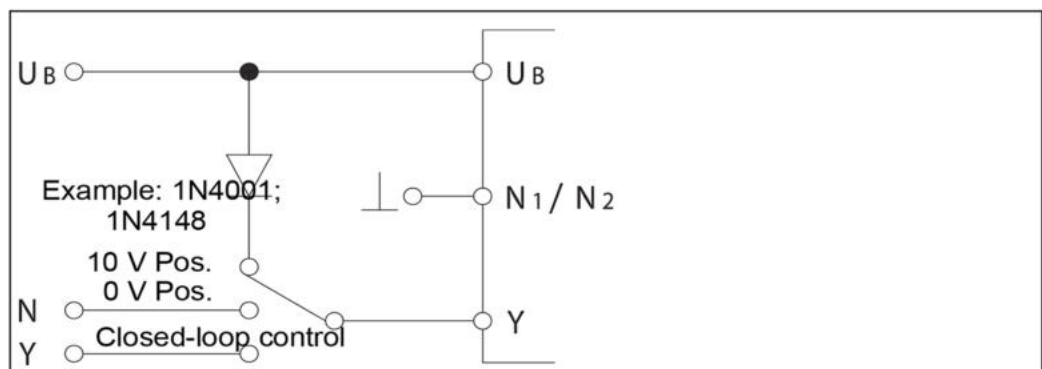

diagram 9 Controller independent circuit

- 2 Using the toggle you can move the linear actuator to the following positions:
 - Closed-loop control by input signal Y (normal operation)
 - 10 V-position
 - 0 V-position, linear actuator can be moved to position selected by encoding switch S7 at 2 ... 10 V .
- ⇒ 5.1 Operating parameters and encoding switch settings on page 22
⇒ 5.7 Setting the limit position on page 25

4.5.2 Removing the PCB cover

To set the linear actuator by using the encoding switch you will first have to remove the PCB cover. **(33)**



Risk of injury from electric shock by live parts!

When the power supply is on there is a danger of electric shock due to live parts.

- Prior to commencing any work, ensure that the actuator is safely disconnected from the power supply system.
- Secure against unauthorised restarting.

- 1 Insert the screwdriver in one of the notches on the cover **(201)** and lift off the cover **(201)**.
- 2 Insert a small screwdriver in the designated notch on the printed circuit cover **(33)** and lift it off.

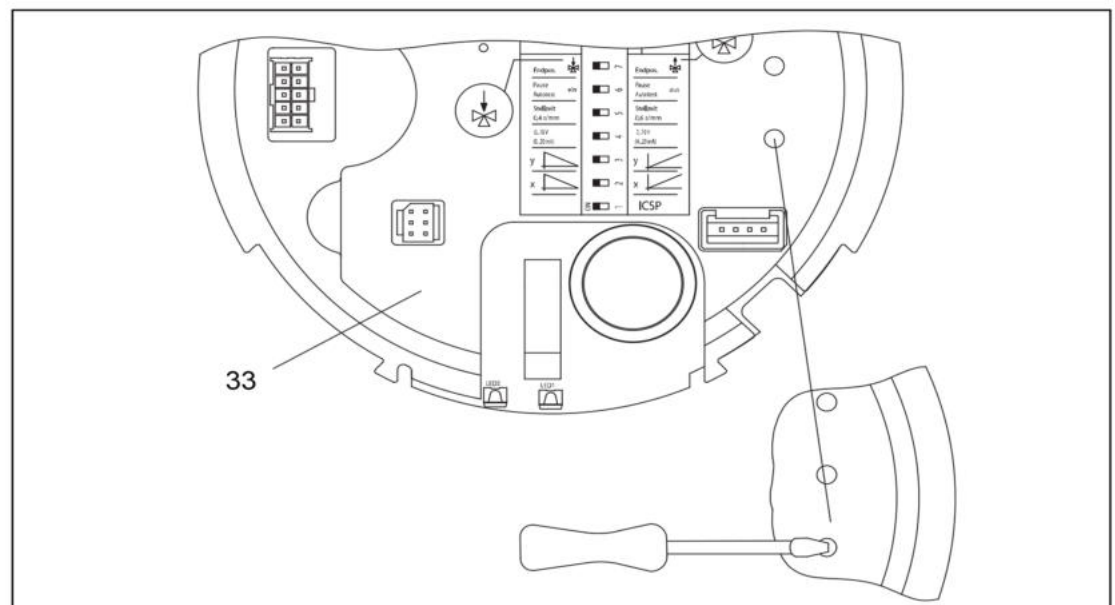

diagram 10 Remove the PCB cover in the actuator housing

- 3 Removing the PCB cover **(33)** in the actuator housing gives you access to **(1)** encoding switches S1 to S10.

4.6 Fitting accessories

Accessories are not part of the scope of delivery for the linear actuator unless expressly ordered! The linear actuators are prepared for retro-fitting with:

- PCB for path switch **(106)**
 - PCB for output signal $X=0/4 \dots 20 \text{ mA}$ **(111)**
- ⇒ 2.2 Accessories on page 7

4.6.1 Fitting a PCB for a path switch



Risk of injury from electric shock by live parts!

When the power supply is on there is a danger of electric shock due to live parts.

- Prior to commencing any work, ensure that the actuator is safely disconnected from the power supply system.
- Secure against unauthorised restarting.

- 1 Open the cover **(201)** of the linear actuator.
⇒ 4.4 Assembling/disassembling the cover on page 14
- 2 Push the path switch PCB **(106)** with the help of the three spacers **(27)** onto the push-fit PCB **(107)**.

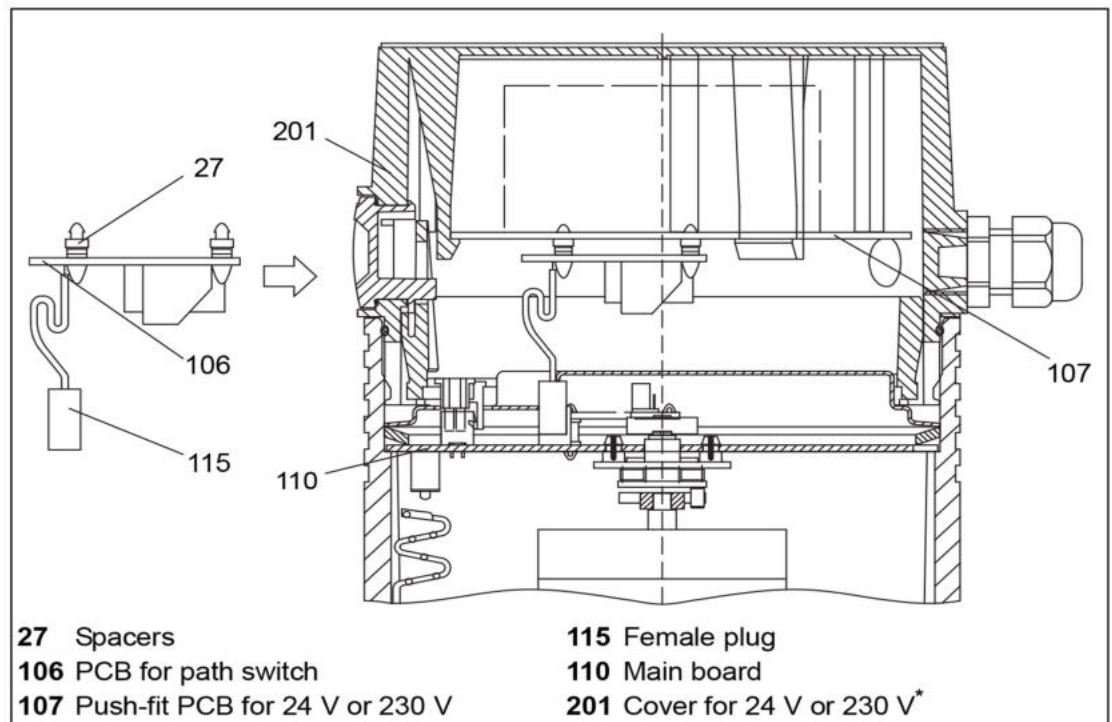

diagram 11 Fitting the position switch PCV inside the cover

- 3 Plug the female plug into the **(115)** path switch PCB **(106)** on the socket board **(123)** of the main PCB **(110)**. In the process pay attention to the notches on the socket board and female plug.

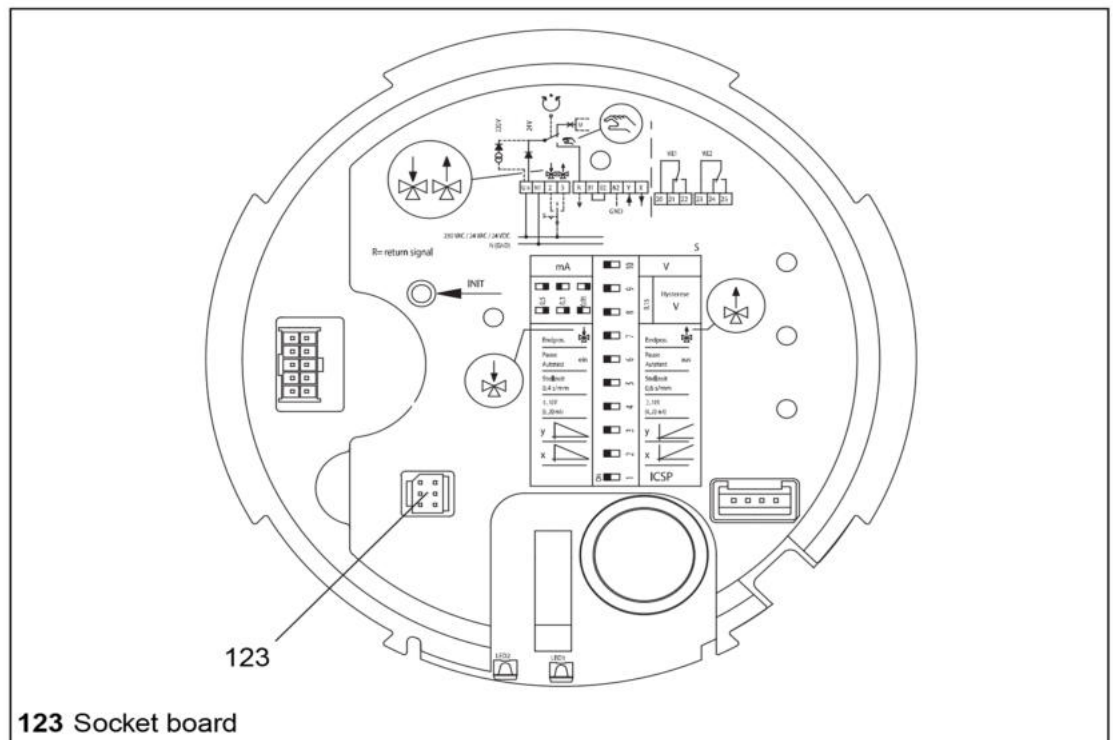

diagram 12 Socket board for position switch PCB on main PCB

- 4 Set the position switches.
⇒ 5.8 *Setting a potential-free path switch* on page 25

4.6.2 Fitting the PCB for the mA output signal



Risk of injury from electric shock by live parts!

When the power supply is on there is a danger of electric shock due to live parts.

- Prior to commencing any work, ensure that the actuator is safely disconnected from the power supply system.
- Secure against unauthorised restarting.

- 1 Open the cover (**201**) and remove the PCB cover(**481**).
⇒ 4.4 *Assembling/disassembling the cover* on page 14
⇒ 4.5.2 *Removing the PCB cover* on page 18
- 2 Remove the jumper (**JP1**) from the main PCB (**110**).
- 3 Push the jumper (**JP1**) onto the plug-in jumper (**113**) of the PCB for the mA output signal.
- 4 Plug in the PCB for the mA output signal (**111**) by pushing its socket board into the plug-in jumper (**113**) of the main PCB (**110**).
- 5 Lock the spacers (**27**) inside the holes of the main PCB.

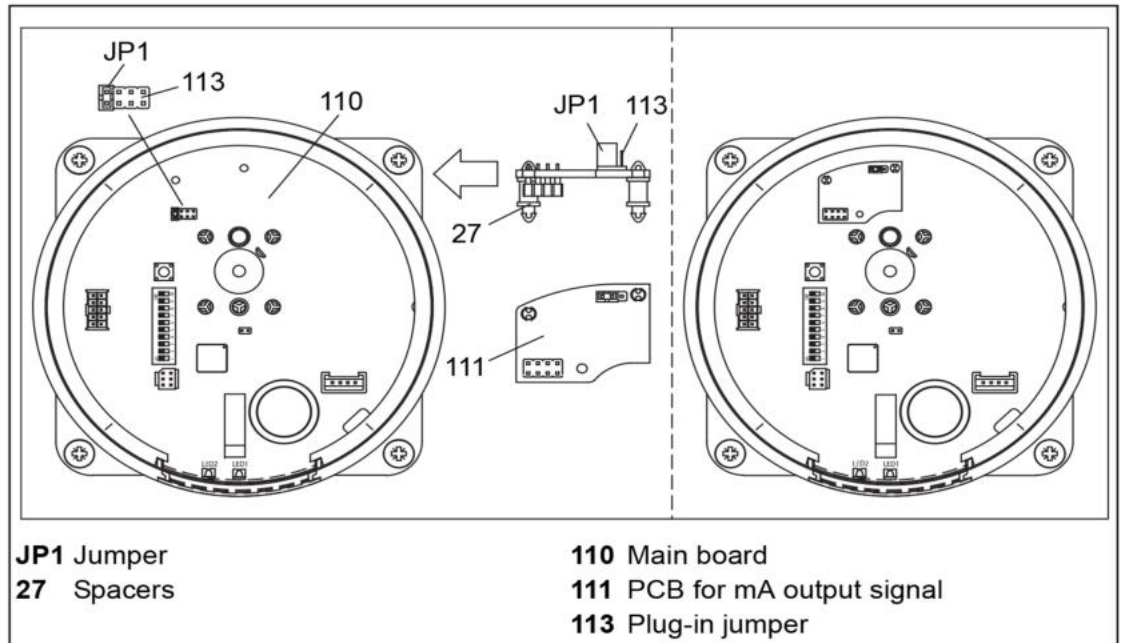

diagram 13 Fitting the PCB for the mA output signal

- 6** Select the signal range for the output signal with the help of the jumper (**JP1**):
- Jumper right: 0 ... 20 mA
 - Jumper left: 4 ... 20 mA

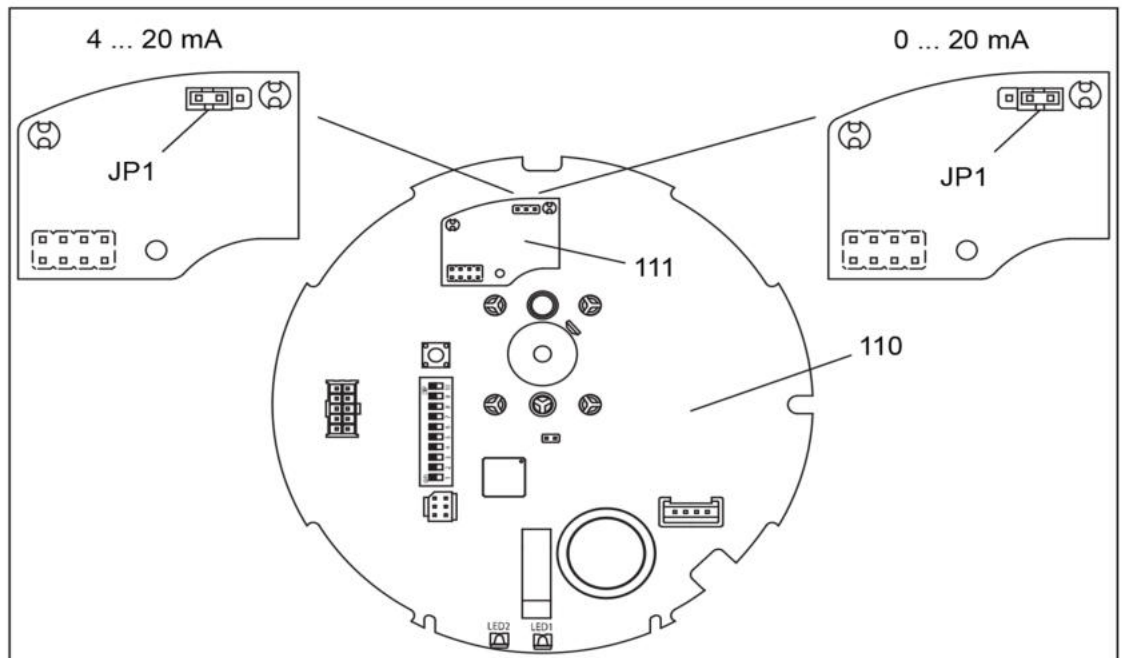

diagram 14 Setting the signal range for mA output signal X

5 Commissioning



Risk of injury from electric shock by live parts!

When the power supply is on there is a danger of electric shock due to live parts.

- Prior to commencing any work, ensure that the actuator is safely disconnected from the power supply system.
- Secure against unauthorised restarting.

The encoding switches (**116**) are used to set the operating parameters. The encoding switches are under the PCB cover (**33**) inside the actuator housing (**1**).

⇒ 4.4 Assembling/disassembling the cover on page 14

⇒ 4.5.2 Removing the PCB cover on page 18

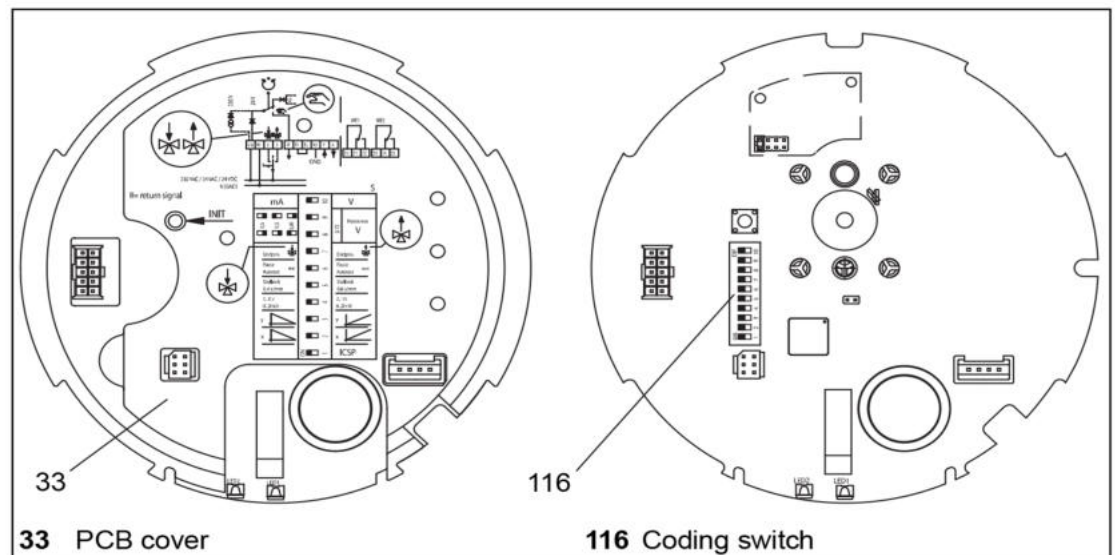

diagram 15 PCB cover and encoding switch

5.1 Operating parameters and encoding switch settings

Prior to return commissioning the linear actuator you will have to set the operating parameters on the encoding switches.



Malfunction caused by incorrect switch position S1

Switch S1 has to be set to "on" at all times.

- Ensure that switch S1 is set to "on"

Switch	on	off
S1	Ready for operation	-
S2	X-characteristic line 	X-characteristic line 
S3	Y-characteristic line 	Y-characteristic line 
S4	Input signal (Y) 0 ... 10 V DC or 0 ... 20 mA	Input signal (Y) 2 ... 10 V DC or 4 ... 20 mA
S5	Actuating time 0.4 s/mm	Actuating time 0.6 s/mm
S6	Auto test and auto pause on	Auto test and auto pause off
S7	Limit position actuator spindle extended	Limit position actuator spindle retracted
S8, S9	S8 and S9 are used to set the hysteresis (0.05 ... 0.5 V).	
S10	Input signal (Y) in mA	Input signal (Y) in V

table 4 Positions of encoding switch

5.2 Setting the input signal

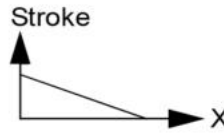
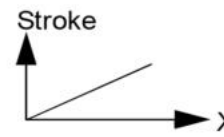
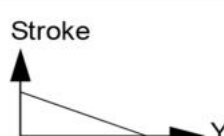
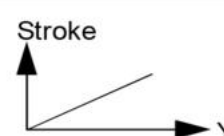
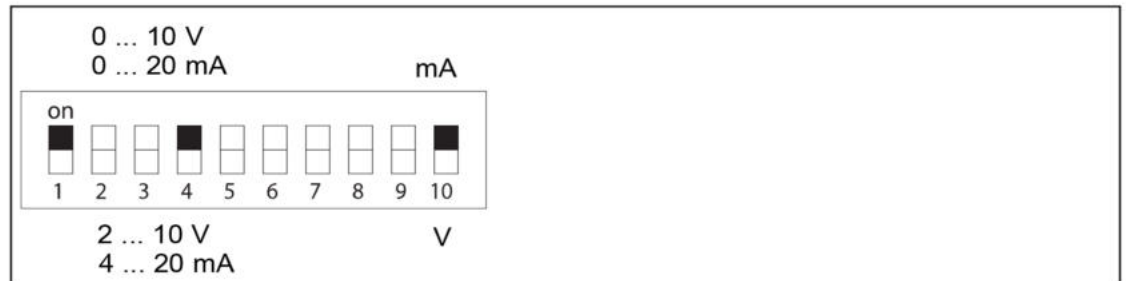

diagram 16 Setting the input signal

⇒ Additional information: *Input signal (Y)* on page 8

5.3 Setting the actuating time

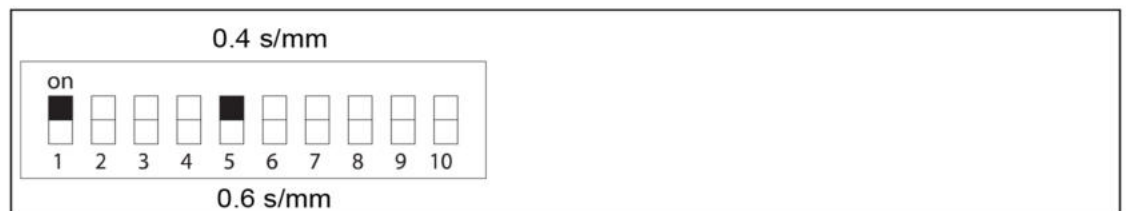

diagram 17 Set actuating time

⇒ Additional information: *2.4.5 Actuating time* on page 9

5.4 Setting the hysteresis

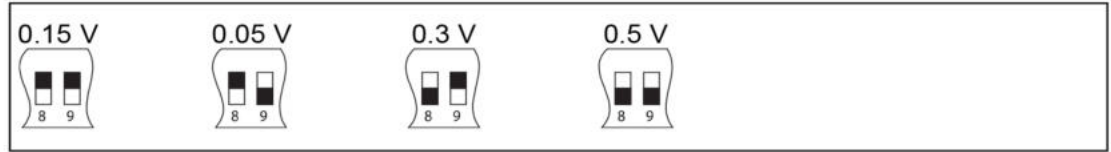

diagram 18 Set hysteresis

⇒ For further information see 2.4.6 Hysteresis on page 9

5.5 Setting the actuating direction

You can use the encoding switch (reverse operation) to reverse the actuating direction of the linear actuator.

Actuator setting	Normal operation	Reverse operation (X and Y reversed)
	Y = 10 V DC Y = 20 mA	Y = 0 V DC Y = 2 V DC Y = 0 mA Y = 4 mA
	Y = 0 V DC Y = 2 V DC Y = 0 mA Y = 4 mA	Y = 10 V DC Y = 20 mA

Encoding switch S2: X (output signal), encoding switch S3: Y (input signal)

table 5 Setting the actuating direction

5.6 Setting auto test and auto pause

Auto test and auto pause are enabled when encoding switch S6 is set to ON. Approximately every 10 days the auto test triggers a start-up towards the limit position in rapid traverse mode. Rebalancing takes place at the same time. During auto pause a break of 3 seconds (measuring cycle 2 min) takes place after more than 20 direction varying traverse commands per minute. These two functions cannot be selected individually.

5.7 Setting the limit position

Encoding switch S7 is used to select the limit position for the linear actuator:

- S7 ON: Limit position with extended spindle nut
- S7 OFF: Limit position with retracted spindle nut

The limit position is approached in the following situations:

- Due to wire break detection by the Y signal (2 ... 10 V DC or 4 ... 20 mA only),
- Due to a binary signal (When electric circuit between terminal B1 and B2 is interrupted),
- During auto test,
- After a cut in supply voltage (manual adjustment)

5.8 Setting a potential-free path switch

Trim-pots P1/P2 is used to set the path switches independently. Try out the sequence of operations for each position switch once.

■ How to set a path switch

- 1 Ensure that the linear actuator has been commissioned and initialised.

⇒ 5.10 Commissioning on page 28

⇒ 5.9 Initialising the path measuring system on page 27



Malfunction caused by imprecisely set path switches!

If you have set the actuator to manual mode (without supply voltage) it is only possible to set the path switch approximately (central setting is the equivalent of a switch point of c. 50% lift).

- To set the path switch accurately, set the actuator to automatic mode.

- 2 Move the actuator to the position where the switch event is to be triggered. Follow the sequence of operations below with the supply voltage turned on.



Risk of injury from electric shock by live parts!

When the supply voltage is turned on there is a risk of electric shock from live parts.

- Take care not to touch any live parts.
 - Take care to apply the tool in a way that does not cause short-circuit.
-

- 3 Open the cover **(201)**.
 ⇒ 4.4 Assembling/disassembling the cover on page 14
 Inside the cover is the path switch PCB **(106)**.
- 4 Use a screwdriver to adjust the trim-pot until the path switch switches. The related LED will either light up or switch off.
 Potentiometer P1 **(105 P1)** is used to set path switch 1.
 LED 1 shows the switching status.
 Potentiometer P2 **(105 P2)** is used to set path switch 2.
 LED 2 shows the switching status.

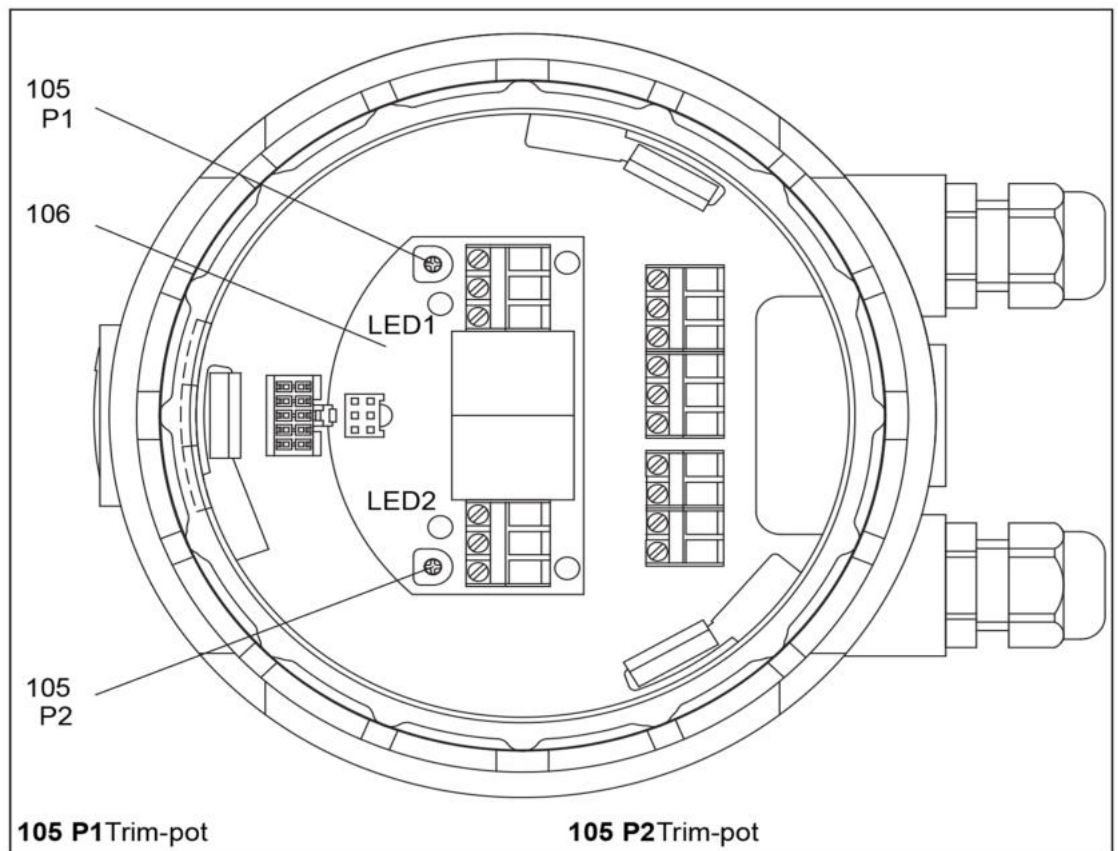

diagram 19 Position switch PCB in cover

- 5 Comply with the allowable contact load for the path switch:

Nominal load	8 A, 250 V AC 8 A, 30 V DC
Switch voltage	max. 400 V AC max. 125 V DC

table 6 Contact load of path switch

- 6 Disconnect the actuator from the supply and connect the path switch contacts.
- 7 Close the cover **(201)** of the linear actuator
 ⇒ How to attach the cover on page 15

5.9 Initialising the path measuring system



Linear actuator starts automatically!

The linear actuator starts immediately after being connected to the supply voltage and automatically moves to a reference point of the path measuring system.

- Wait until this reference point has been reached and the linear actuator has stopped.

The path measuring system has to be initialised after the following:

- At initial commissioning
- After repairs to the valve or actuator
- After a replacement of valve or actuator

Initialisation may be triggered in two different ways.

■ How to initialise via the initialising button



Risk of injury from electric shock by live parts!

When the supply voltage is turned on there is a risk of electric shock from live parts.

- Take care not to touch any live parts.
- Take care to apply the tool in a way that does not cause short-circuit.

- 1 Open the cover (**201**).
⇒ 4.4 Assembling/disassembling the cover on page 14
- 2 Ensure that supply voltage is applied.
- 3 Press the initialising button (**118**) and keep it pressed for at least 1 second.

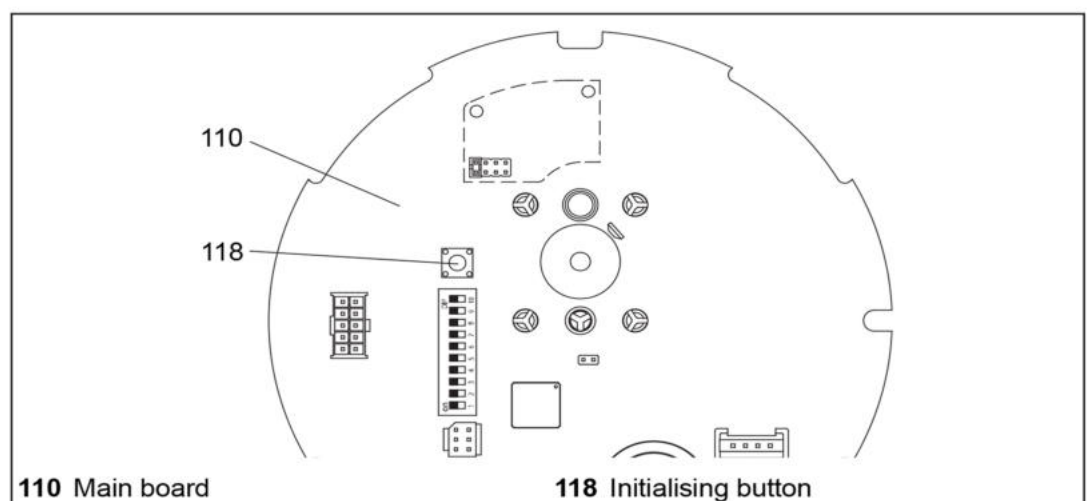

diagram 20 Initialising the path measuring system

■ How to initialise via the connecting terminals

- 1 Apply supply voltage simultaneously to terminals 2 and 3, making sure that supply voltage is applied for at least 1 second.
⇒ *diagram 8* on page 16

5.10 Commissioning

- 1** Check whether all fitting and assembly work has been competently finished.
⇒ *4 Assembly on page 12*
- 2** Ensure that the electrical actuation of the linear actuator can take place safely without putting people or devices at risk.
- 3** Ensure that the linear actuator is attached correctly and that the cover of the linear actuator is closed.
⇒ *4.4 Assembling/disassembling the cover on page 14*
- 4** Ensure that the linear actuator is set to automatic mode.
⇒ *6.1 Changing between manual and automatic mode on page 29*
- 5** Ensure that the operating parameters are set correctly.
⇒ *5.1 Operating parameters and encoding switch settings on page 22*
- 6** Ensure that the path measuring system is initialised.
⇒ *5.9 Initialising the path measuring system on page 27*
- 7** Apply supply voltage. The linear actuator will now move to the reference point.
The linear actuator is ready for operation.

6 Operation

Prior to commissioning the linear actuator you will have to initialise it and select the operating mode.

⇒ 5 Commissioning on page 22

⇒ 5.9 Initialising the path measuring system on page 27

6.1 Changing between manual and automatic mode

It is possible to run the linear actuator in automatic mode or manual mode (manual adjustment).

- In automatic mode the spindle nut moves to the position set by the controller.
- In manual mode it is possible to set the spindle manually, e. g. for control purposes. Output signal (X) is not available in manual mode.

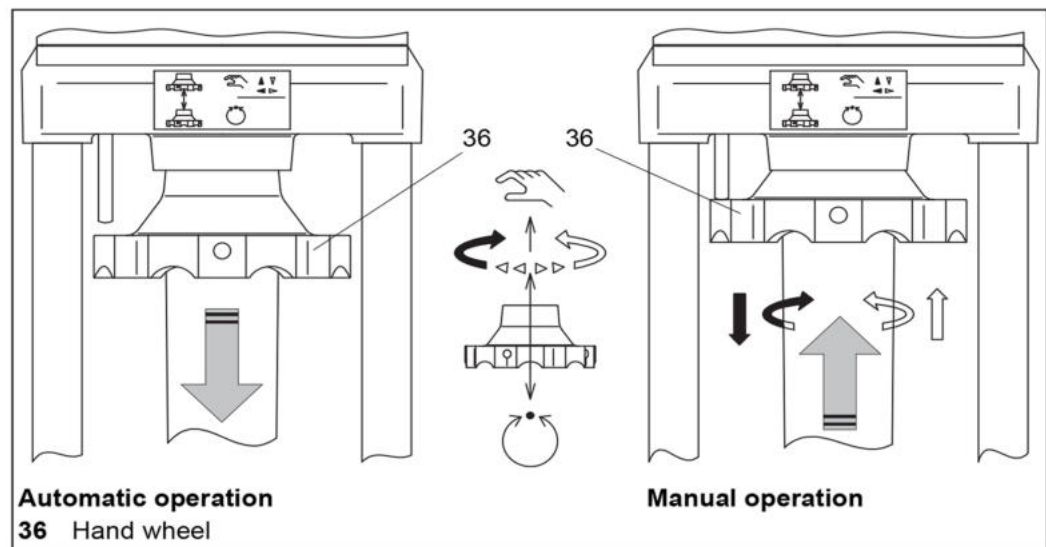

diagram 21 Selecting automatic mode

■ How to change-over in manual mode

- 1 Move the hand wheel (36) to manual mode position by turning until the hand wheel locks noticeably.



Risk of damage to valve and actuator during manual mode!

The valve may get damaged if it is pushed too hard into its receptacle during manual mode.

- Do not try and keep turning the hand wheel when you realise that the required effort increases noticeably!
- Never use force !

- 2 Use the hand wheel to turn the spindle nut to the desired position. Turn the hand wheel until the preset potentiometer increases. Do not use force!

■ How to change-over in automatic mode

- 1 Push the hand wheel (36) to automatic mode position.
- 2 The linear actuator first moves to the position specified by encoding switch S7 and afterwards to the position set by the controller.

6.2 LED display

The LEDs on the viewing panel (47) show the operating status or errors.

⇒ 10.2 Check list for breakdown on page 32









Green LED	Operating status / error
 Duration	Normal operation, ready for operation The LED is permanently lit, actuator waiting for traverse command.
  0,5s 0,5s 0,5s 0,5s	Standard Operation Actuator carries out traverse command.
  0,2s 1,5s 0,2s 1,5s Short – long rhythm	Wire break detection Input signal has dropped below 1 V or below 2 mA in operating modes 2 ... 10 V DC or 4 ... 20 . ⇒ 2.4.4 Wire break detection on page 9
  2,5s 2,5s 2,5s 2,5s Long – long rhythm	Blockage detection (continuous mode only) The linear actuator is mechanically blocked. ⇒ 2.4.2 Blockage detection on page 8
  1,5s 0,2s 1,5s 0,2s Long – long rhythm	Continuous signal on terminal 2 and 3 A simultaneous control signal at terminal 2 and 3 will result in an initialising cycle (max. 4 attempts). The linear actuator will automatically switch off after 4 unsuccessful attempts.

table 7 Display green LED





Red LED	Operating status / error
 off	Temperature in normal range
 Duration	Heating mode ⇒ Actuator heating on page 9
  0,25s 0,25s 0,25s 0,25s Flashed regularly	Actuator overheating ⇒ Overheating protection on page 8

table 8 Display red LED

7 Maintenance, care and repairs

The linear actuator requires little maintenance. You do not have to carry out continuous or periodical maintenance.

8 Spare parts

When ordering accessories and spare parts please quote the specifications engraved on the type plate of your linear actuator. The specifications on the type plate are standard for the technical date of linear actuators as well as the requirements for the public power supply.



Damage to device caused by faulty spare parts!

Spare parts must match the technical data specified by the manufacturer.

- Use genuine spare parts at all times.
-

⇒ 2.1 *Component parts* on page 6

⇒ 2.2 *Accessories* on page 7

9 Decommissioning and disposal

Dispose of the linear actuator according to national regulations and laws.

10 Removal of faults

After remedying faults you will have to re-initialise the path measuring system.

⇒ 5.9 *Initialising the path measuring system* on page 27

10.1 How to remedy faults

If the linear actuator does not work properly follow the sequence of operations described below in order to remedy the fault:

- 1 Check whether the linear actuator was correctly assembled.
- 2 Check the settings for the linear actuator against the specifications on the type plate.
- 3 Remedy the fault by following the check list.
⇒ 10.2 *Check list for breakdown* on page 32
- 4 If you are unable to remedy the fault contact the manufacturer.
- 5 For all queries at the manufacturer's and when sending back the device please quote the following :
 - SN (serial number = order number)
 - Type denomination
 - Supply voltage and frequency
 - Accessory equipment
 - Error report
- 6 If you are unable to remedy the fault despite inquiry you can send the device to the manufacturer.

10.2 Check list for breakdown

Fault	Cause/reason	Remedy
1. Linear actuator is not working.	Hand wheel (36) is in position manual mode	<input type="checkbox"/> Turn hand wheel to position automatic mode.
	Power cut	<input type="checkbox"/> Determine cause and remedy.
	Fuse defective (in control cabinet)	<input type="checkbox"/> Determine cause and remedy, replace fuse.
	Linear actuator incorrectly connected	<input type="checkbox"/> Set connection correctly according to wiring diagram (on cover).
	Short circuit due to humidity	<input type="checkbox"/> Determine cause, dry the linear actuator; replace cover seal or screw joints and/or attach protective cover, as required.
	Short circuit due to incorrect connection	<input type="checkbox"/> Correct setting for connection
	Motor has winding damage (burnt-out) <ul style="list-style-type: none"> • e.g. voltage too high • Electronic system defective 	<input type="checkbox"/> Determine cause, measure current data, Compare to type plate and table, Disassemble linear actuator and send it in for repairs.
2. Linear actuator running unsteadily, i. e. veering between clockwise and anti-clockwise rotation.	Drop of voltage due to excessively long connecting cables and / or insufficient diameter.	<input type="checkbox"/> Measure the current data; if required, recalculate and replace connecting cables!
	Public power supply fluctuations greater than admissible tolerance ⇒ 2.5 <i>Technical data</i> on page 10	<input type="checkbox"/> Improve public power supply conditions
3. Linear actuator pauses intermittently or initialises frequently	Slack contact in feeder line	<input type="checkbox"/> Check and tighten connections (terminal strips)
4. Linear actuator does not move to limit position. Valve does not open/close.	Valve is stuck	<input type="checkbox"/> Provide smooth-running valve
	Excessive system pressure	<input type="checkbox"/> Adjust system pressure
5. Linear actuator does not move at all or not correctly to the position preset by input signal Y	Input signal Y is faulty: <ul style="list-style-type: none"> • Interfering signals • Signal variations 	<input type="checkbox"/> Check input signal Y on linear actuator, remove cause of fault
	Main PCB defective	<input type="checkbox"/> Replace main PCB or disassemble linear actuator and send it in for repair
6. Green LED is flashing in long / long rhythm	Blockage detection was triggered	<input type="checkbox"/> Press INIT and observe actuator during initialisation.
		<input type="checkbox"/> Check valve for smooth-running along entire traverse range
7. Green LED is flashing in short / long rhythm	Wire break was detected	<input type="checkbox"/> Measure desired value voltage and current on linear actuator
8. Green LED is flashing in long / short rhythm	Relay contact adhesive	<input type="checkbox"/> Check controller
9. Red LED flashing evenly	Actuator overheating	<input type="checkbox"/> Motor has switched off automatically. After cooling down, automatic start-up

table 9 Check list breakdown