

Operating Manual

Linear actuator

MLH2503

General Informations

Amendment	Version	Date	Modifications
	1.0	December 2015	Initial preparation

Copyright The copyright for this operating manual as well as all rights in case of patent awarding or registration of registered design remains with the manufacturer!

Subject to alteration The regulations, directives, standards etc. are compliant with the current state of information at the time of development and are not subject to modification service. They must be applied by the operator at his own responsibility in their latest valid version.

Concerning all data, information, and illustrations in this manual we reserve the right of technical modifications and improvements. No claims can be considered for alteration or rework of already delivered lift drives.

Table of contents

1 Safety	4	4 Assembly	12
1.1 Proper use	4	4.1 Checking the scope of delivery	12
1.2 Information for the operator	4	4.2 Preparing assembly	12
1.3 Personnel	5	4.3 Mounting the linear actuator on the valve	13
1.4 Prior to starting work	5	4.4 Assembling/disassembling the cover	14
1.5 During operation	5	4.4.1 Function head disassemble / assemble	16
1.6 Working environment	5	4.5 Electrical connection	17
2 Product Specification	6	4.5.1 Screw plug-in terminals	19
2.1 Component parts	6	4.5.2 Plug / Harness assignment	20
2.2 Accessories	7	4.6 Fitting accessories	21
2.3 Operating modes	7	4.6.1 Fitting a PCB for a path switch	21
2.3.1 Continuous mode	7	4.6.2 Fitting the PCB for the mA output signal	22
2.3.2 Three-point mode	8	5 Commissioning	24
2.3.3 Local control	8	5.1 Operating param. and encoding switch settings ..	24
2.4 Functions	8	5.2 Setting the input signal	25
2.4.1 Binary signal	8	5.3 Setting the hysteresis	25
2.4.2 Wire-break detection	9	5.4 Setting the actuating direction	26
2.4.3 Actuating time	9	5.5 Setting end position in a binary event	26
2.4.4 Hysteresis	9	5.6 Setting a potential-free path switch	26
2.4.5 Manual mode and response signal	9	5.7 Initialising the path measuring system	29
2.4.6 Potential-free limit switch (accessory)	9	5.7.1 Basic setting of position measuring system ..	30
2.5 Technical data	10	5.8 Commissioning	31
2.6 Type plate	11	6 Operation	32
3 Transportation and Storage	11	6.1 Changing between manual and automatic mode ..	32
		6.2 LED display	33
		6.2.1 Light signals optional	34
		7 Maintenance, care and repairs	34
		8 Spare parts	34
		9 Decommissioning and disposal	35
		10 Removal of faults	35
		10.1 How to remedy faults	35
		10.2 Check list for breakdown	36
		11 Notes	37

1 Safety

Read these Operating Instructions carefully particularly the following safety instructions prior to installation and operation.



DANGER

Directly threatening hazard leading to death or serious physical injuries.



WARNING

Potentially hazardous situation which may lead to death or serious physical injuries.



CAUTION

Potentially hazardous situation which could lead to minor physical injuries. Indicates a hazard which may cause material damage.



ATTENTION

Potentially hazardous situation where the product or an object in its environment may get damaged.

Hint: Utilisation instructions and other useful information.

1.1 Proper use

Linear actuators are controlled by three-point control or constant control. Linear actuators in the series described in these Operating Instructions are used for valve stroke adjustment.

Concurrence of the above type designation with the linear actuator rating plate must be checked prior to starting any operations in order to guarantee utilisation in accordance with specification. The data on the rating plate is decisive for linear actuator technical data and mains power supply requirements.

Any utilisation for tasks other than the aforementioned usage in accordance with specification and operating with mains power supply ratios other than those permitted is not deemed to be utilisation in accordance with specification. The operator bears sole liability for the risk to persons and machine and other assets in the event of utilisation not in accordance with specification.

The intended use also includes the compliance with accident preventions, DIN VDE regulations and safe working practices for all measures described in these operating instructions in due consideration of prevailing rules.

1.2 Information for the operator

Always keep the Operating Instructions available at the linear actuator deployment site.

Observe the current health and safety, accident prevention and DIN VDE standards for installation, operation and maintenance.

Take into consideration any additional regional, local or in-house safety regulations.

Ensure that every person entrusted with one of the tasks specified in these Operating Instructions has read and understood these instructions.

1.3 Personnel

Only qualified personnel may work on these linear actuators or in their vicinity. Qualified persons are those persons entrusted with installation, assembly, commissioning and operation or maintenance of the linear actuators and possessing the appropriate qualifications for their activity. The necessary and prescribed qualifications include:

- Training / instruction or authorization to turn on /off circuits and appliances / systems according to EN 60204 (DIN VDE 0100 / 0113) and the standards of safety technology.
- Training or instruction according to the standards of the safety technology concerning care and use of adequate safety and work protection equipment.
- First Aid training.

Work in a safe manner and refrain from any working practice which endangers the safety of persons or damages the linear actuator or other assets in any way whatsoever.

1.4 Prior to starting work

Prior to starting any work, check that the type designations specified here concur with the data on the linear actuator rating plate.

Linear actuator MH2503.

1.5 During operation

Safe operation is only possible if transportation, storage, installation, operation and maintenance are carried out safely and materially and professionally correctly.

Transportation, installation and assembly

Observe the general set-up and safety regulations for heating, ventilation, air-conditioning and pipework design. Use tools correctly. Wear the necessary personal and other safety equipment.

Repairs and maintenance

Ensure that qualified personnel switch off the linear actuator prior to maintenance or repair work in accordance with DIN VDE.

1.6 Working environment

Read the data concerning the working environment in the Technical Data.

2 Product Specification

The linear actuators control a stepper motor by means of a micro controller. The stepper motor's rotational movement is converted into a linear movement via planetary gears and a threaded spindle with spindle nut.

2.1 Component parts

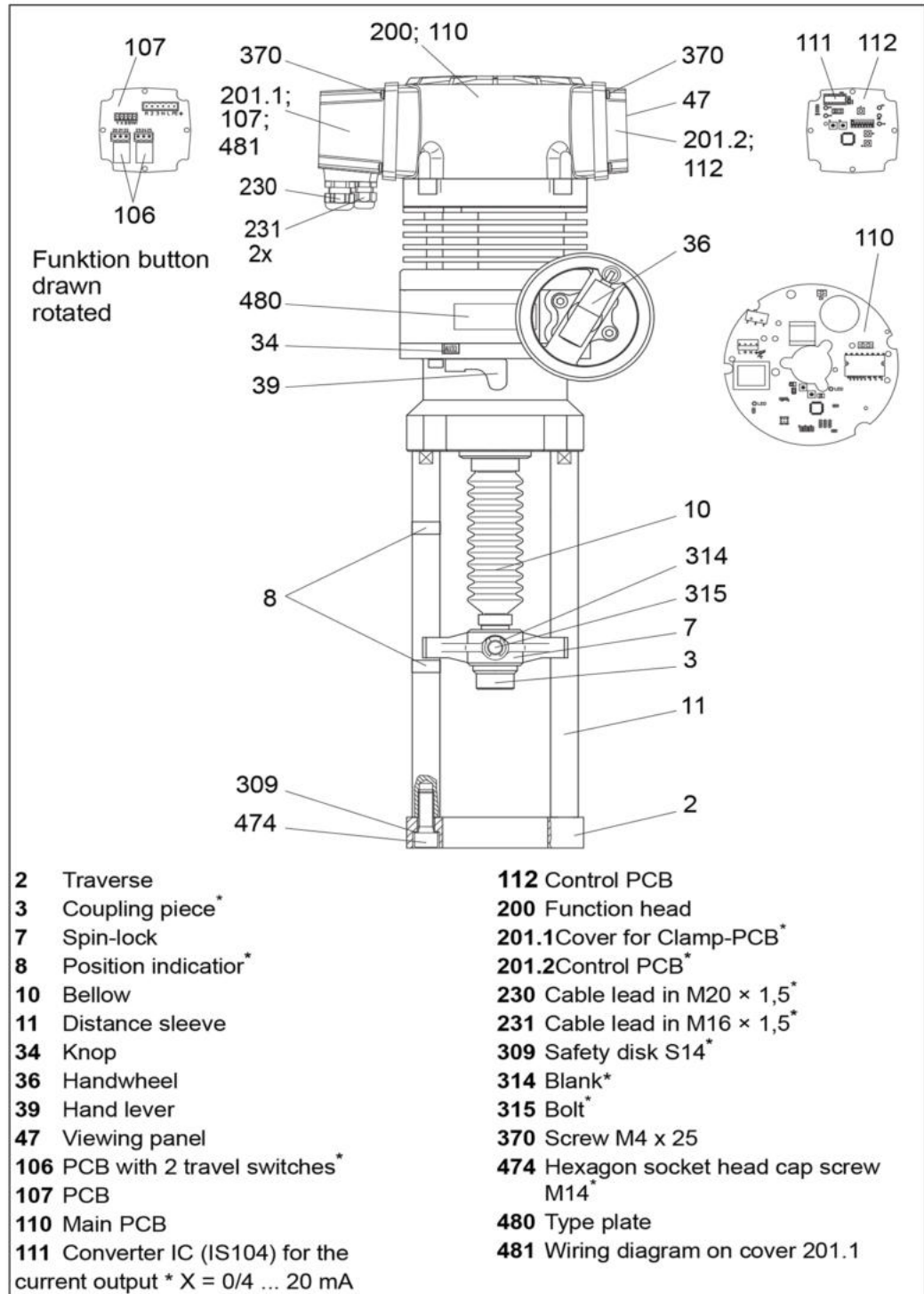

diagram 1 Component part denominations

* This component is available as a spare part!

2.2 Accessories

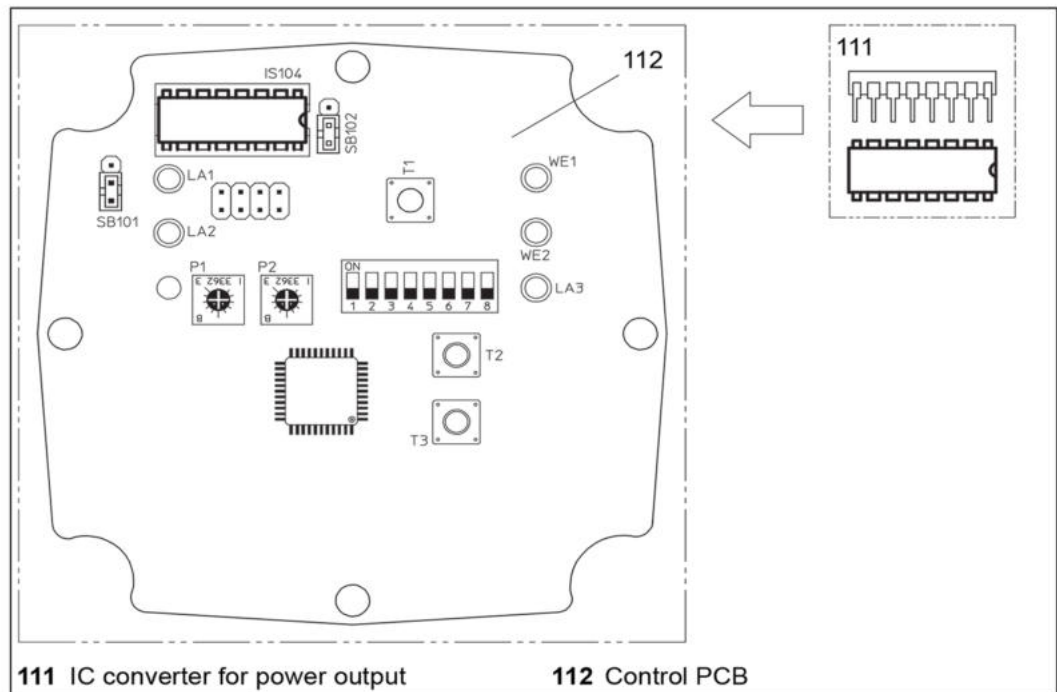

diagram 2 Converter IC (111) for current output signal on the control board (112)

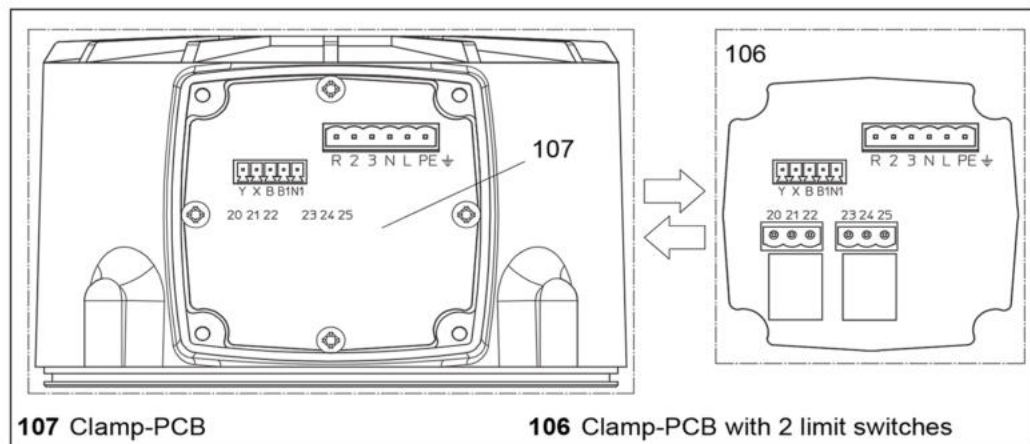

diagram 3 Clamp with 2 position switch-PCB(107) under the cover (201.1)

2.3 Operating modes

The linear actuator can be operated manually or automatically.

- In manual mode stroke is adjusted via the hand wheel.
- In automatic mode stroke is controlled electrically.

2.3.1 Continuous mode

In continuous mode the system control presets the position of the linear actuator. The built-in drive positioner compares the predetermined desired position (Y) with the actual position of the driving spindle (X). The driving spindle is moved until its position to the target value (y).

The output-signal X is the current position of the spindle.

In continuous mode a driving command carried out the green and orange LED light up continuously. The actuator is indicated by a flashing green LED light.

input signal(Y) The analog input signal (Y) of the system control specifies the desired position for the linear actuator. It is applied in the form of an analogue signal to terminal Y.

Possible analog input signals:

- 0 ... 10 V / 2 ... 10 V
- 0 ... 20 mA / 4 ... 20 mA

output signal (X) The analog output signal (X) determines the actual position of the linear actuator. It is applied to terminal X in the form of an analogue signal.

0% to 100% valve lift is put out as:

- 0 ... 10 V or 2 ... 10 V
- 0 ... 20 mA or 4 ... 20 mA (Accessories IC converter for current output(111)on terminal X)

2.3.2 Three-point mode

The direction of rotation is set via controlvoltage at terminal 2 and terminal 3:

- When the control voltage is applied to terminal 2, the spindle nut will be extended.
- When the control voltage is applied to terminal 3, the spindle nut will be retracted.
- In the three-point mode, the green LED lights up permanently. If a move command carried out, the green LED flashes.

2.3.3 Local control

Local control mode allows the operator to adjust the actuator "locally",. The direct adjustment on the actuator is possible. Except the „MAN“-mode (manual adjustment). The local control mode is superior to all other operating modes. The operating mode local control is indicated by alternating flashing (flashing alternately) the green and the orange LED.

Button 3 (T3) = actuator spindle retracts

Button 2 (T2) = drive extends

The function of the limit switch and the X signal is maintained.

Simultaneous pressing of the keys T2 and T3 → drive changes to normal operation (alternating flashing of the green and the orange LED ends).

2.4 Functions

2.4.1 Binary signal

Terminals B and B1 at screw terminal (SK1) are bridged it not in use. If the connection between B and B1 interrupted, the actuator stem move in the end position which was selected by DIL switch 5.

The operating mode „binary mode“ (interruption of low impedance connection between B and B1) is indicated by flashing of green and orange LED in unision.

⇒ 4.5.1Screw plug-in terminals on page 17

If the connection between B and B1 ist restored, the actuator resumes following the the controlling signals at terminal 2,3 (TP) or Y

2.4.2 Wire-break detection

Wire break detection is only available for continuous mode with an input signal 2 ... 10 V DC and 4 ... 20 mA.

If the input signal drops below 1V/2mA the actuator stem remains in it's current position. The wire-break is indicated by the red LED flashing.

An increase of the input signal above 1 V or 2 mA causes a return to the continuous operation mode. If there is a binary signal while the actuator is in wire-break operating mode, the binary signal has priority. The wire break is still displayed.

During a wire-break the actuator stem can be moved by hand.

2.4.3 Actuating time

The time required for the spindle nut to travel a defined distance is called actuating time. Actuating time is specified in s/mm.

2.4.4 Hysteresis

Hysteresis equals the difference of the input signal (Y) that is required after a reversal of signal direction in order to move the spindle nut.

It serves to prevent permanent oscillation of the actuator motor around a certain hoisting position during minor input signal alterations.

⇒ 5.3 Setting the hysteresis on page 23

2.4.5 Manual mode and response signal

In manual mode it is possible to change the lift without supply voltage.

- Motor and control electronics are turned off in manual mode to make hoisting movements of the control impossible.
- The moment you set the linear actuator to manual mode the control switches a signal to terminal R, provided supply voltage is applied.

⇒ 4.5.1 screw plug terminal on page 17



The feedback voltage at terminal "R" has the power supply potential of the conductor L!

2.4.6 Potential-free limit switch (accessory)

The path switch relay allow you to set up separate elays in relation to the stroke. The adjustment of the switching point can be done with the potentiometer P1 and P2 (105) located on the control-PCB. The switching status of the path switch relay (106) is indicated by the yellow-colored LED's (1 or 2).

2.5 Technical data

Typ	MLH2503
Supply Voltage	230 V +6% -10% Control mode for a short time ≤ 500 VA
Input	Motor without load ≤ 25 VA standby power ≤ 10 VA
Weight (with "standard" mounting kit)	~24 kg
Dimensions	See technical data sheets
Stroke	100 mm
Frequency	50 Hz ± 10 Hz
Ambient temperature	-10°C ... +60°C
Operating mode	S3 50% ED
Enclosure protection	IP 65
Actuating time	0,5 s/mm
Actuating force	25 kN

table 1 Technical specifications

Input signal Y / Resistance of load	<ul style="list-style-type: none"> • 0 ... 10 V / 77 kΩ • 2 ... 10 V / 77 kΩ • 0 ... 20 mA / 510 Ω • 4 ... 20 mA / 510 Ω
Output X / Load rating	<ul style="list-style-type: none"> • 0 ... 10 V / burden ≥ 1200 Ω, I_{max}. 8 mA • 0 ... 20 mA / burden ≤ 500 Ω - converter IC with accessories for power output (111) • 4 ... 20 mA / burden ≤ 500 Ω - converter IC with accessories for power output (111)
Response signal R / load rating	• 230 V AC / I_{max} . 1 A
Cable impedance between B1 and B2	• max. 10 Ω

table 2 Technical data signals

2.6 Type plate

The type plate is attached to the housing of the linear actuator. It bears the type denomination, serial number (s/no) and date of manufacture (last four digits).

⇒ 2.1 Component parts on page 6



		 
MLH2503		
F.-Nr.: 07204142/01/0607		
AC 50 Hz 230 V	max. 500 VA	25 kN
Y=0...10 V	IP 65	0,5 s/mm
X=0...10 V	S3 50% ED	Stroke 100 mm

diagram 4 Example of type plate

3 Transportation and Storage



Non-compliance with safety regulations may result in injury!

- Wear the required personal and other safety equipment.
- Avoid impacts, blows, vibrations etc. to the linear actuator.
- Store the linear actuator (and, where appropriate, the entire controlling device) in a dry place.
- Keep to the specified transport and storage temperatures between -20 to +65°C

4 Assembly

Prior to assembling the linear actuator:

- ⇒ 4.1 *Checking the scope of delivery* on page 12
- ⇒ 4.2 *Preparing assembly* on page 12

The following sequence of operations is part of the linear actuator assembly:

- ⇒ 4.3 *Mounting the linear actuator on the valve* on page 13
- ⇒ 4.4 *Assembling/disassembling the cover* on page 14
- ⇒ 4.5 *Electrical connection* on page 17

4.1 Checking the scope of delivery

- 1 Check the packaging for damage.
- 2 Dispose of packaging in an environmentally friendly manner.
- 3 Check the delivered items against the delivery note in order to see whether the delivery is complete.
- 4 Report any missing or damaged products to the manufacturer.

4.2 Preparing assembly



A non-attached valve causes damage!

If you operate the linear actuator without valve, the spindle nut may fall off due to the missing stop.

- Always operate the linear actuator with a valve attached.

- 1 Allow for about 200 mm space above the cover at the site of installation.
- 2 Check the working environment before assembling and commissioning the linear actuator:
- 3 Ensure that the valve is correctly fitted. For details please see assembly instructions for valve.
- 4 Determine the assembly position of the linear actuator. Do not arrange linear actuators in a hanging position.

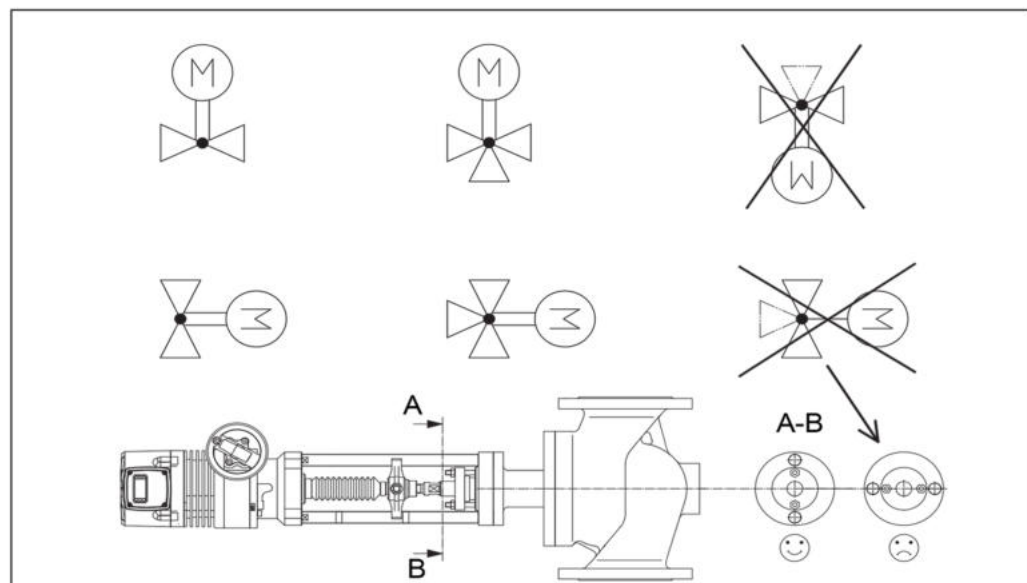

diagram 5 Assembly positions of linear actuator and valve

4.3 Mounting the linear actuator on the valve

If the linear actuator and the valve are supplied separately, the linear actuator must be mounted on the valve.

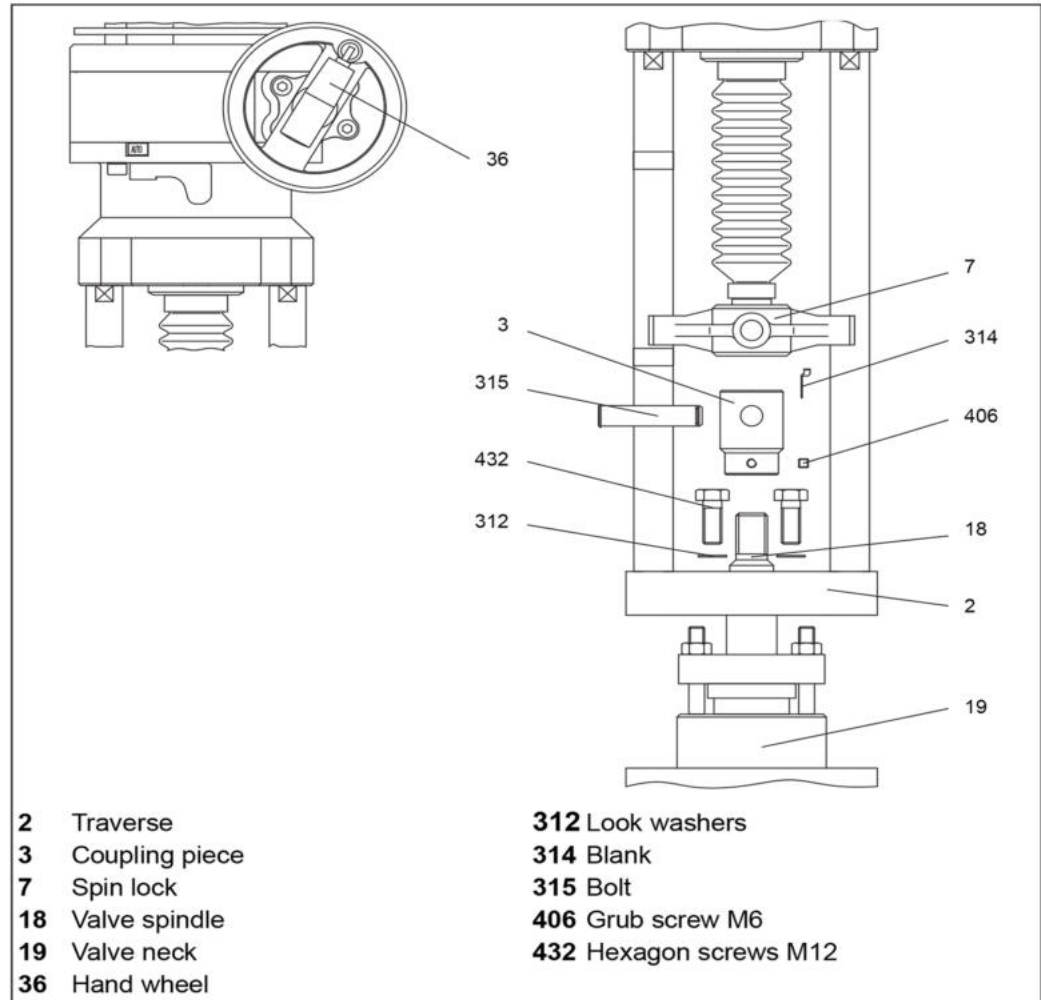

diagram 6 Mounting the linear actuator on the valve

■ How to mount the linear actuator

- 1** Pull of the blank (314).
⇒ diagram 6 on page 13
- 2** Pull out the bolt (315) from the coupling piece (3) or drive it out.
- 3** Turn the coupling piece (3) onto the valve spindle (18).
- 4** Put the traverse (2) on the valve neck (19).
- 5** Fix the traverse (2) using the screws (432) (wrench size 19) and blanking plate (312) on the valve neck (19).
- 6** Insert the spin lock (7) on the coupling piece (3).
- 7** Hold the actuator spindle against rotation and adjust them by hand wheel (36) in height so until the holes for the bolts (315) in spin lock (7) and actuator spindle are aligned.
- 8** Mount the bolts (315).
- 9** Insert the blank (314)!
- 10** Tighten the hexagon screw (406) in the coupling piece (3) firmly.

■ **How to disassemble the linear actuator**

- 1 Perform the steps in the reverse order of assembly.

4.4 Assembling/disassembling the cover

The terminals for the electrical connection are under the cover (201.1).

The coding (116) are under the cover (201.2).



WARNING

Risk of injury from electric shock by live parts!

When the power supply is on there is a danger of electric shock due to live parts.

- Prior to commencing any work, ensure that the actuator is safely disconnected from the power supply system.
- Secure against unauthorised restarting.
- Remove the cover only momentarily.

■ **How to remove the cover**

- 1 Loosen the screws (370) (Torx T20 ®) on the cover.

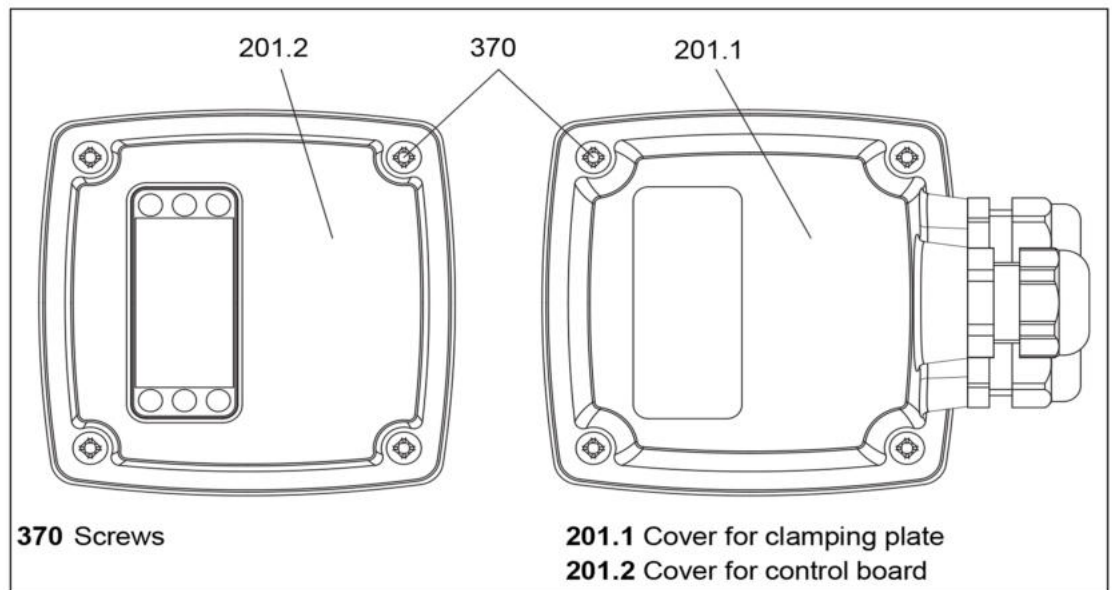

diagram 7 Removing the cover

- 2 Remove the cover (201.1 / 201.2) carefully.

Damage cables result in damage to devices !

When removing or replacing the cover, you may tear off or damage the cabling inside the cover.

- Remove the cover carefully and put it on gently.

- 3 Pull the screw clamp terminals (106) on the determined connectors.

⇒ 4.5.1 Screw plug-in terminals on page 13

- **To put the cover on**
 - 1 Insert the previously stripped screw clamp terminals (106) in the corresponding connector of the terminal board (107).
 - 2 Pay attention to the notch on the plug and socket!
 - 3 Put the cover (201.1 / 201.2) and tighten the screws (370) (Torx T20 ®) evenly to strong.
Pay attention to the correct position of the cable glands and the viewing window.
Pay attention to the correct fit of the grooved rubber seal in the cover.
 - 4 Check the proper fit of the lid, so that tightness is guaranteed.
⇒ 4.5.1 Screw plug-in terminals on page 19

4.4.1 Function head disassemble / assemble



Read instruction manual and pay attention!
Risk of injury by electric shock!

- The device reliably disconnected from the mains.
 - Unplug!
 - Wait 10 minutes until the capacitor is discharged!
 - Secure against unauthorized switching.
 - Take the function head (200) from only temporarily.
-

■ **To remove a function header**

- 1 Loosen the screws (465) (Allen Gr. 4) the function head (200). Ensure that the disks (305) are not lost.
 - 2 Raise the functional head (200) carefully, possibly with a screwdriver or similar, carefully pry off.
 - 3 Pull the plug (3, 4, 5, 7, 9) on the motherboard (110) and the control board (112).
⇒ diagram 11 connector / cable harness on page 20 Assignment
 - 4 Take the function head (200) carefully in direction of the arrow.
-



Damaged cables result in damage to devices!

When lifting the cover you may tear off or damage the cabling inside the cover.

- carefully remove the cover
-

■ **To reset the function head**

- 1 Raise the functional head (200) about the components and decrease it in the retained position.
-



Pay attention to the correct seat of the O-ring in the groove. The O-ring must not be damaged.

- 2 Insert the plug (3, 4, 5, 7, 9) back onto the motherboard (110) and the control board (112).
⇒ diagram 11 connector / plug/harness assignment on page 18
- 3 Be when installing the heatsink (A) on the main board must using the wall of the function head (200) is engaged (in the direction of center of the board), only then the function head (200) can be placed.
- 4 Insert the discs (305) on the screws (465) and tighten the screws (465) (hexagonal socket Gr. 4).
- 5 Check the proper fit of the function head (200) so that the tightness is ensured.

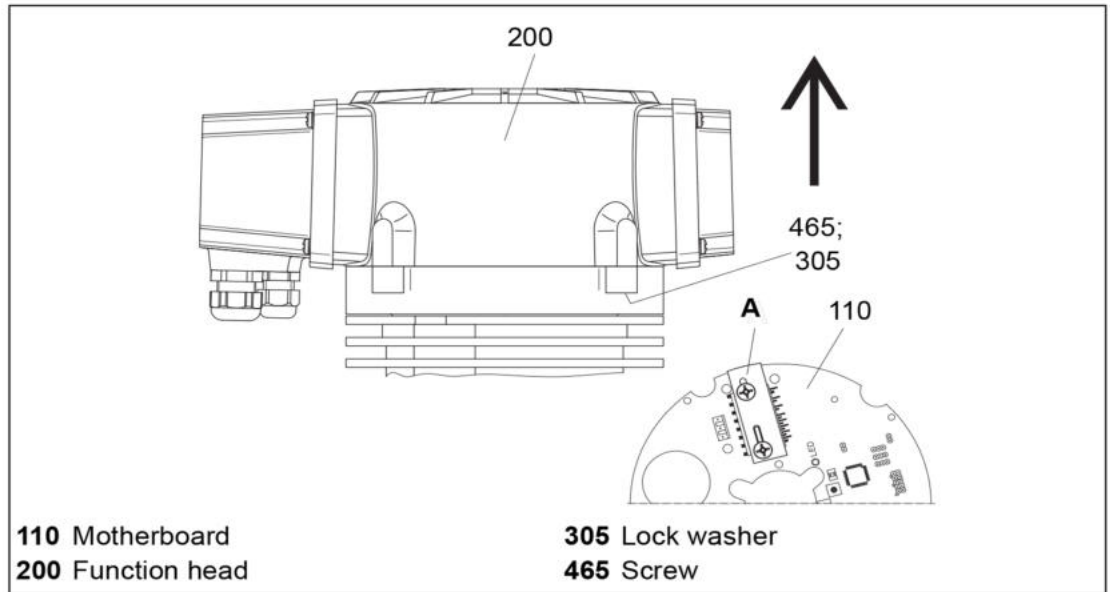

diagram 8 Detaching the function head

4.5 Electrical connection



WARNING

Danger of life caused by incompetent staff!

Electrical connections carried out by unqualified staff may result in death, severe bodily injury or considerable material damage.

- Make sure that such all work is carried out by qualified staff.
- ⇒ 1.3 Personnel on page 5



WARNING

Risk of injury from electric shock by live parts!

When the supply voltage is turned on there is a risk of electric shock from live parts.

- Prior to commencing any work, ensure that the actuator is safely disconnected from the power supply system.
- Secure against unauthorised restarting.

■ **How to prepare the electric connection**

- 1 Ensure that the supply voltage matches the specifications on the type place of the linear actuator.
- 2 To avoid breakdown, construct the line diameter according to actuating performance and required line length.
- 3 Lay the mains for a supply voltage of > 48 V separate from the signal and control wires.

When laying cables in a joint cable duct, use shielded control wires.

- 4 Check the supply voltage.

If the required tolerance of the supply voltage with a power transformer can not be met, the usage of a AC voltage stabilizer is needed.

⇒ 2.5 Technical data on page 9

Terminal	Description
L	Supply voltage
N	Neutral
2	Control voltage for downward movement during three-point mode
3	Control voltage for upward movement during three-point mode
R	Feedback voltage in "Manual mode" <ul style="list-style-type: none"> • R = 230 V max. 1 A
B, B1	Binary-input / frost protection function
N1	Zero potential of the signals X, Y <ul style="list-style-type: none"> • If the zero potentials of signals X, Y are identical to the zero potential of the supply voltage, you can use the terminals N1 and N2 bridge. • If you operate the drive in continuous operation with 230V, then you have to connect N2. • If you operate the drive in three-point operation with 230V, then you have to connect N2 if you wish to use additional X.
PE	Protective conductor
Y	Modulating control operation
X	Output steady operation
20, 21, 22	Terminals path switch relay WE1
23, 24, 25	Terminals path switch relay WE1

table 3 Legend to wiring diagram

4.5.1 Screw plug-in terminals

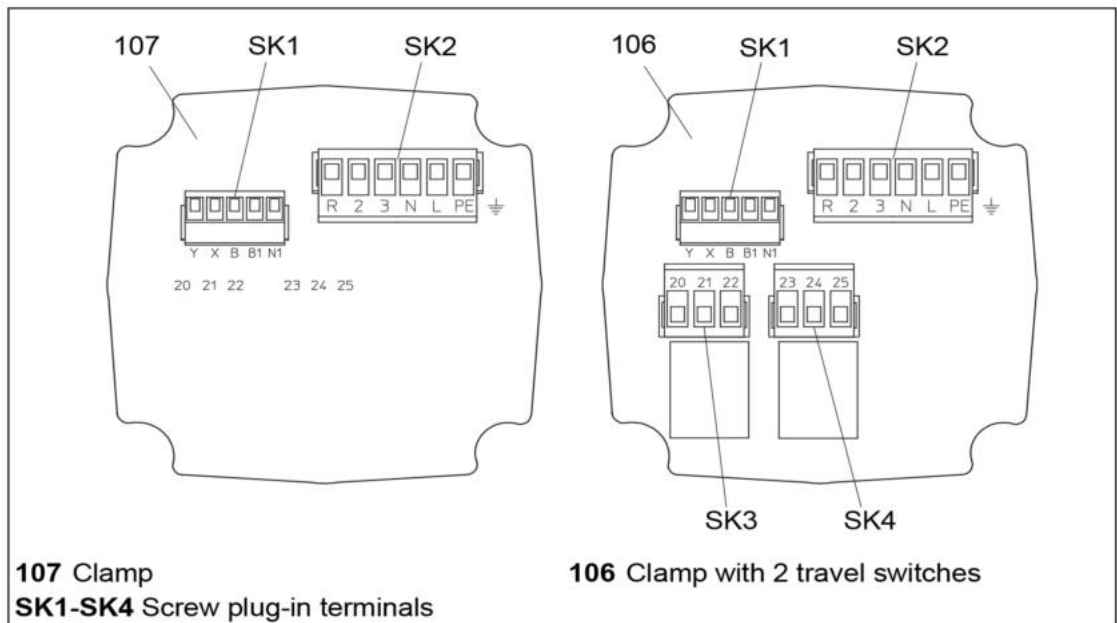

diagram 10 Screw plug-in terminals

4.5.2 Plug / Harness assignment

(1) Motor connection	→ (1) Plugged plug on the motherboard
(2) Signal line	→ (2) Plugged plug on the motherboard
(3) Position measuring system	→ (3) Plugged plug on the control board
(4) Choke in the function header (200)	→ (4) Plugged plug on the motherboard
(5) Connecting cable on the clamping plate with 2 limit switches	→ (5) Plugged plug on the motherboard
(6) Connecting cable on the clamping plate with 2 limit switches	→ (6) Plugged plug on the control board
(7) Line on the control board	→ (7) Plugged plug on the motherboard
(8) Line to the clamping plate with 2 limit switches (optional)	→ (8) Connector plugged on the control board (optional)
(9) Connector plugged into the motherboard (optional)	→ (10) Connector plugged on the control board (optional)

table 4 Plug / Harness assignment

Pay attention to the correct position of the plug.

To disassemble the function head (200), the connector 3, 4, 5, 7, 9, have to be deduced.

⇒ diagram 11 connector / cable harness on harness assignment 20

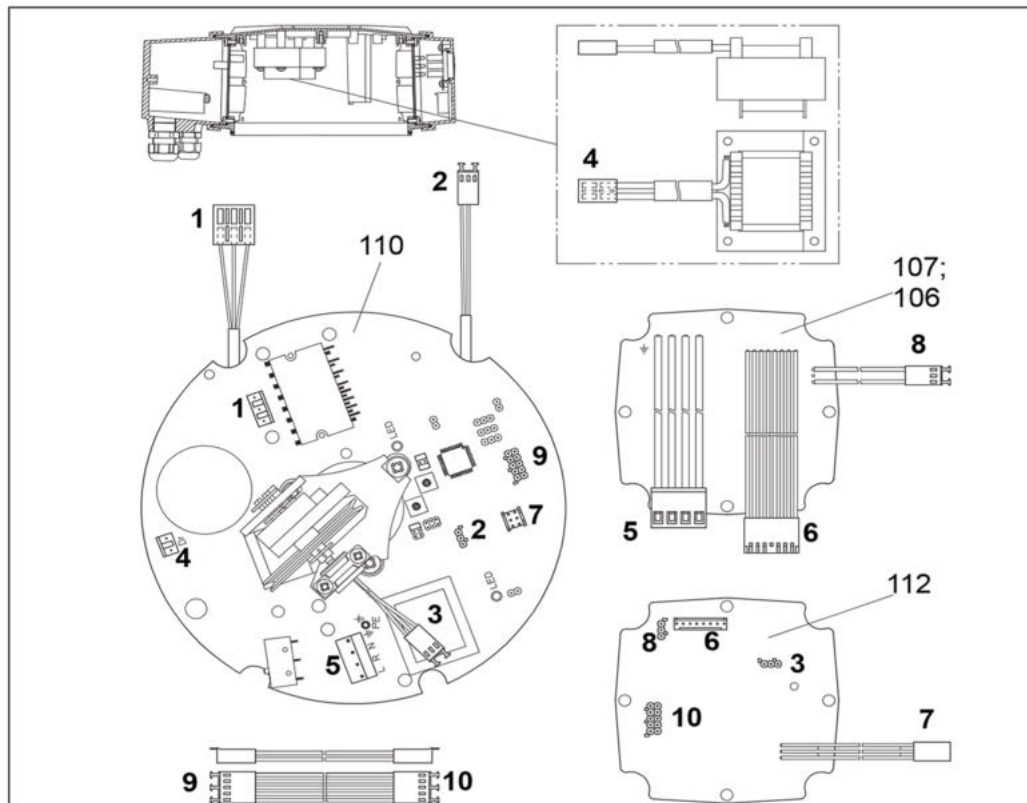

diagram 11 Plug / Harness assignment

4.6 Fitting accessories

Accessories are not part of the scope of delivery for the linear actuator unless expressly ordered! The linear actuators are prepared for retro-fitting with:

- Clamp with 2 limit switches (106)
- Converter IC (IS104) (Integrated Circuit) (111) for current output signal $X = 0/4 \dots 20 \text{ mA}$

⇒ 2.2 Accessories on page 7

4.6.1 Fitting a PCB for a path switch



Risk of injury from electric shock by live parts!

When the power supply is on there is a danger of electric shock due to live parts.

- Prior to commencing any work, ensure that the actuator is safely disconnected from the power supply system.
 - Secure against unauthorised restarting.
-

- 1 Loosen the screws (370) (Torx T20 ®) on the cover.
- 2 Remove the cover (201.1) carefully. Loosen the screw terminals while (106) on the terminal board (107).
- 3 Remove the function head (200).
⇒ 4.4.1 Function Head disassemble / assemble on page 16
- 4 Loosen the screws (369) (Torx T20 ®) on the terminal board. Make sure that the serrated lock washers (307) will not be lost.
- 5 Remove the terminal board (107) carefully and carry it out the harnesses.
- 6 Remove the terminal board with 2 limit switches (106) and run the cables down strands in the function head (200) and connect the appropriate plug to the control board.
⇒ Table 4 Plug / Harness Assignment on page 20
- 7 Place the serrated lock washers (307) under the screws (369) (® Torx T20) and tighten the screws (369) to the terminal board with 2 travel switches.
- 8 Place the function head (200).
⇒ 4.4.1 Function Head disassemble / assemble on page 16
- 9 Replace the cover (201.1) and insert it the
⇒ To put the cover on page 15
Screw plug (SK1-SK4) back to the terminal board with 2 limit switches (106).
- 10 Tighten the screws (370) (Torx T20 ®) on the cover (201.1) firmly.
Pay attention to the correct position of the cable glands.
- 11 Check the proper fit of the lid, so that tightness is guaranteed.
- 12 Set the limit switch.
⇒ 5.6 Setting Potential free limit switches on page 26

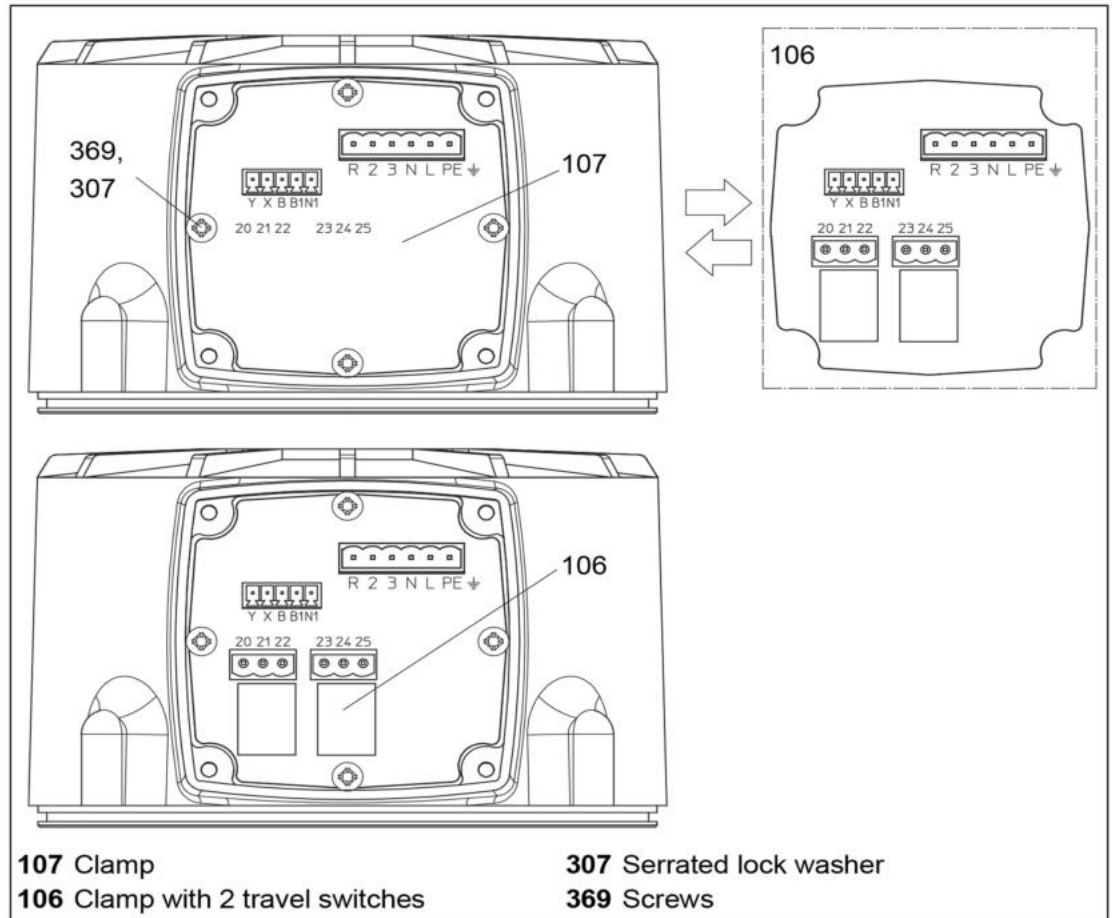

diagram 12 Installation of the clamping plate with 2 travel switches under the cover

4.6.2 Fitting the PCB for the mA output signal

Risk of injury from electric shock by live parts!

When the power supply is on there is a danger of electric shock due to live parts.

- Prior to commencing any work, ensure that the actuator is safely disconnected from the power supply system.
- Secure against unauthorised restarting.

- 1 Open the cover (201.2).
⇒ 4.4 Assembling/disassembling the cover on page 14
- 2 Put the converter IC for the current output signal to the terminal legs into the socket on the control board (112).
- 3 Pay attention to the correct installation position of the converter IC!
⇒ diagram 13 converter IC (111) for current output signal on the control board (112) on page 23

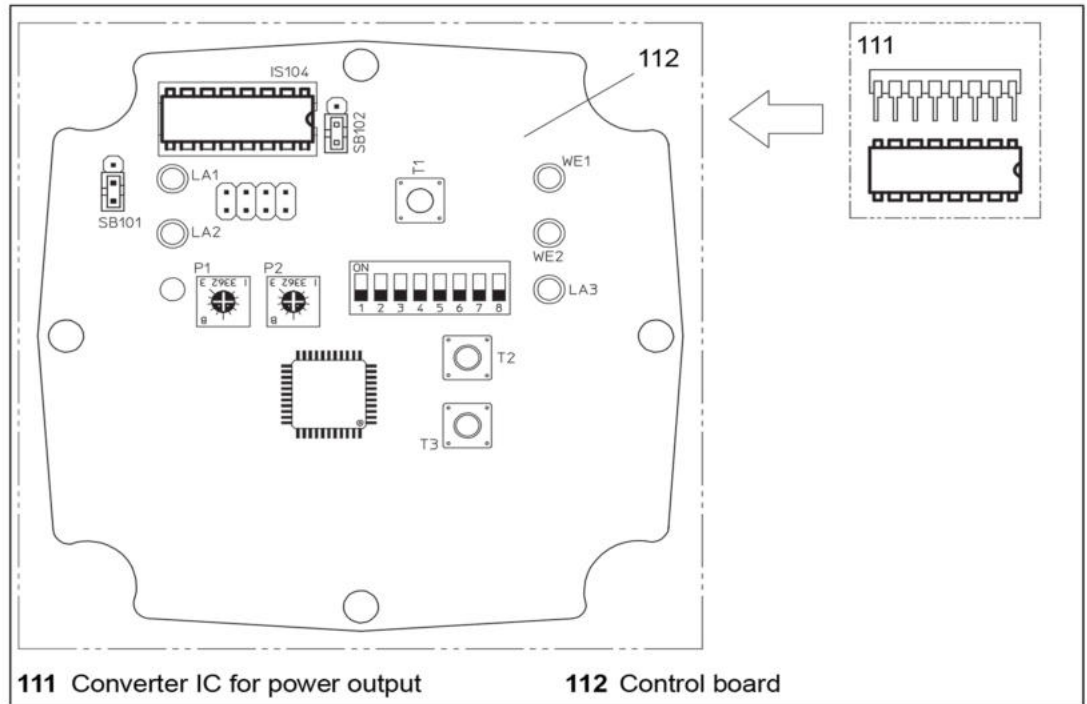

diagram 13 Converter IC (111) for current output signal on the control board (112)

- 4** Select the signal range of the output signal with the jumper (SB 101):
 - SB101 up: 0 ... 20 mA
 - SB101 down: 4 ... 20 mA

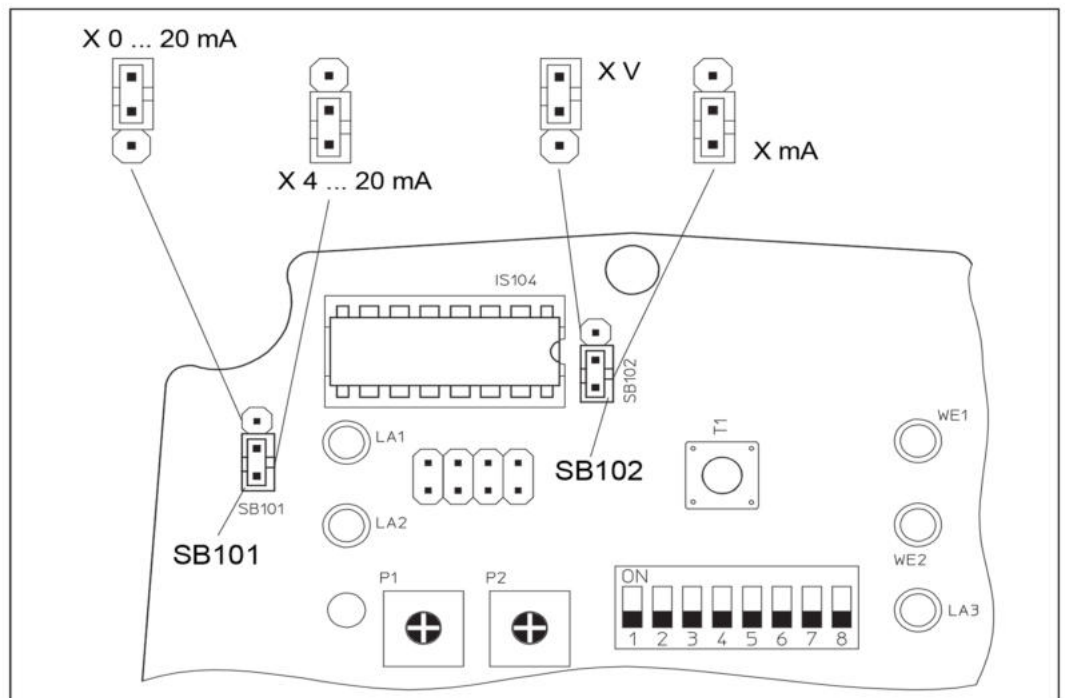

diagram 14 Setting the signal range for mA output signal X

- 5** Select the signal range of the output signal with the jumper (SB 102):
 - SB102 up: V
 - SB102 down: mA

5 Commissioning

Risk of injury from electric shock by live parts!

When the power supply is on there is a danger of electric shock due to live parts.

- Prior to commencing any work, ensure that the actuator is safely disconnected from the power supply system.
- Secure against unauthorised restarting.

During commissioning, the device is in the operation mode continuous operation. Is applied to a three-point inputs 2 and 3 the control voltage, the drive goes to the three-point operation mode.

After a shutdown of the actuator (by switching on the manual mode or shutdown or power failure), the operating mode remains the same.

The instrument is in principle after each initialization, in the steady operation mode.

With the DIP switches (116) the operating parameters are selected. The Encoding switches are located under the cover (201.2).

⇒ 4.4 Assembling/disassembling the cover on page 13

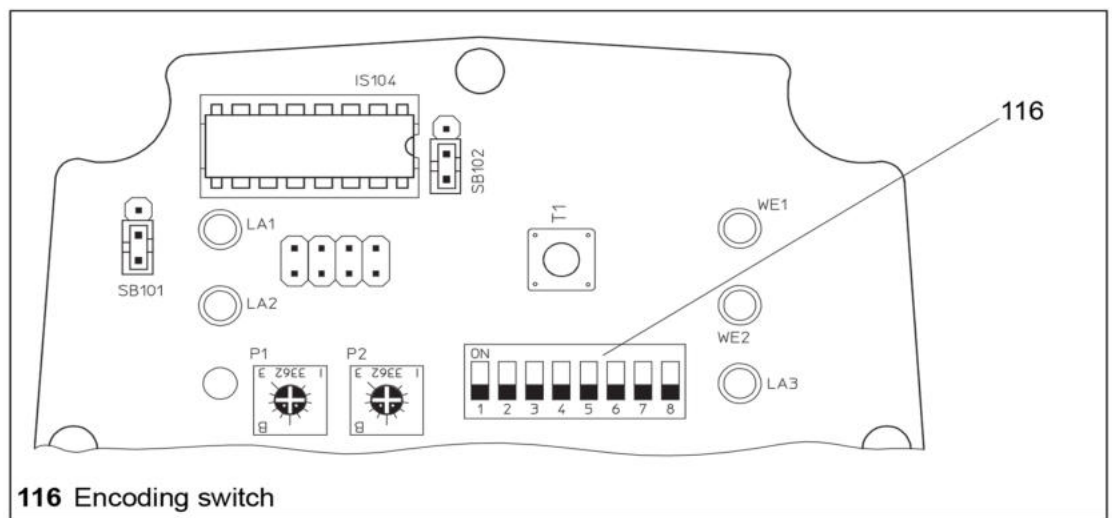

diagram 15 Encoding switch

5.1 Operating parameters and encoding switch settings

Prior to commissioning the linear actuator you will have to set the operating parameters on the encoding switches.

Malfunction caused by incorrect switch settings S1

Switch S1 has to be set to "on" at all times.

- Ensure that switch S1 is set to "on"



switch / Jumper	on	off
S1	Ready	-
S2	X-characteristic line 	X-characteristic line 
S3	Y-characteristic line 	Y-characteristic line 
S4	Input (Y) 0 ... 10 V DC or. 0 ... 20 mA	Input(Y) 2 ... 10 V DC or. 4 ... 20 mA
S5	Limit position actuator spindle extended	Limit position actuator spindle retracted
S6, S7	With S6 and S7, the hysteresis (0.05 ... 0.5 V) is set	
S8	Input signal (Y) in mA	Input signal (Y) in V

table 5 Positions of encoding switch

5.2 Setting the input signal

diagram 16 Setting the input signal

⇒ For more information: input signal (Y) on page 18

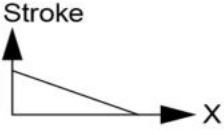
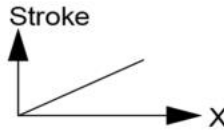
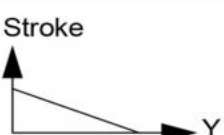
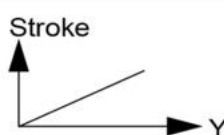
5.3 Setting the hysteresis

Bild 17 Set hysteresis

⇒ Further information 2.4.4 Hysteresis on page 9

5.4 Setting the actuating direction

You can use the encoding switch (reverse operation) to reverse the actuating direction of the linear actuator.

drive control	Normal operation	Reverse operation (X and Y reversed)
	Y = 10 V DC Y = 20 mA	Y = 0 V DC Y = 2 V DC Y = 0 mA Y = 4 mA
		Y = 0 V DC Y = 2 V DC Y = 0 mA Y = 4 mA

Encoding switch S2: X (output signal), encoding switch S3: Y (input signal)

table 6 Setting the actuating direction

5.5 Setting end position in a binary event

The coding switch S5 select the final position of the linear actuator when entering a Binärereignisses:

- S5: Final position with extended spindle nut
- S5 OFF: Final position with retracted spindle nut

The end position is approached in the following situations:

- in a binary event (circuit between terminals B and B1 is interrupted).

5.6 Setting a potential-free path switch

Trim-pots P1/P2 is used to set the path switches independently. Try out the sequence of operations for each position switch once.

■ To set a path switch

- 1 Ensure that the linear actuator has been commissioned and initialised.
 - ⇒ 5.8 Getting started on page 28
 - ⇒ 5.7 Initialising the path measuring system on page 26



Malfunction caused by imprecisely set path switches!

If you have set the actuator to manual mode (without supply voltage) it is only possible to set the path switch approximately (central setting is the equivalent of a switch point of c. 50% lift).

- To set the path switch accurately, set the actuator to automatic mode.
-

The following steps you have to perform when power is being supplied.

- 2 Move the actuator to the position where the switch event is to be triggered. Follow the sequence of operations below with the supply voltage turned on.
-

**Risk of injury from electric shock by live parts!**

When the supply voltage is turned on there is a risk of electric shock from live parts.

- Take care not to touch any live parts.
 - Take care to apply the tool in a way that does not cause short-circuit.
-

- 3 Open the cover (201.2).

⇒ 4.4 Assembling/disassembling the cover on page 14

Under the lid is the control board (112).

Recommendation:

Adjust the stroke of the actuator with the local control.

The position can be checked on the basis of the X signal.

Prerequisite: actuator is initialized.

- 4 Twist the trimmer with a screwdriver until the path switch switches. The switching status is indicated by the associated LED hearing.

With the potentiometer P1 (105) to set the path switch. 1

The LED WE 1 (yellow) indicates the switching status

With the potentiometer P2 (105) set the path switch. 2

The LED WE 2 (yellow) indicates the switching status.

Turn the potentiometer clockwise until it stops → Limit switch always switched on

Turning the potentiometer counter-clockwise until it stops → Limit switch always off

In between any shift position can be selected with the potentiometer.

⇒ diagram 18 control board under the cover on page 28

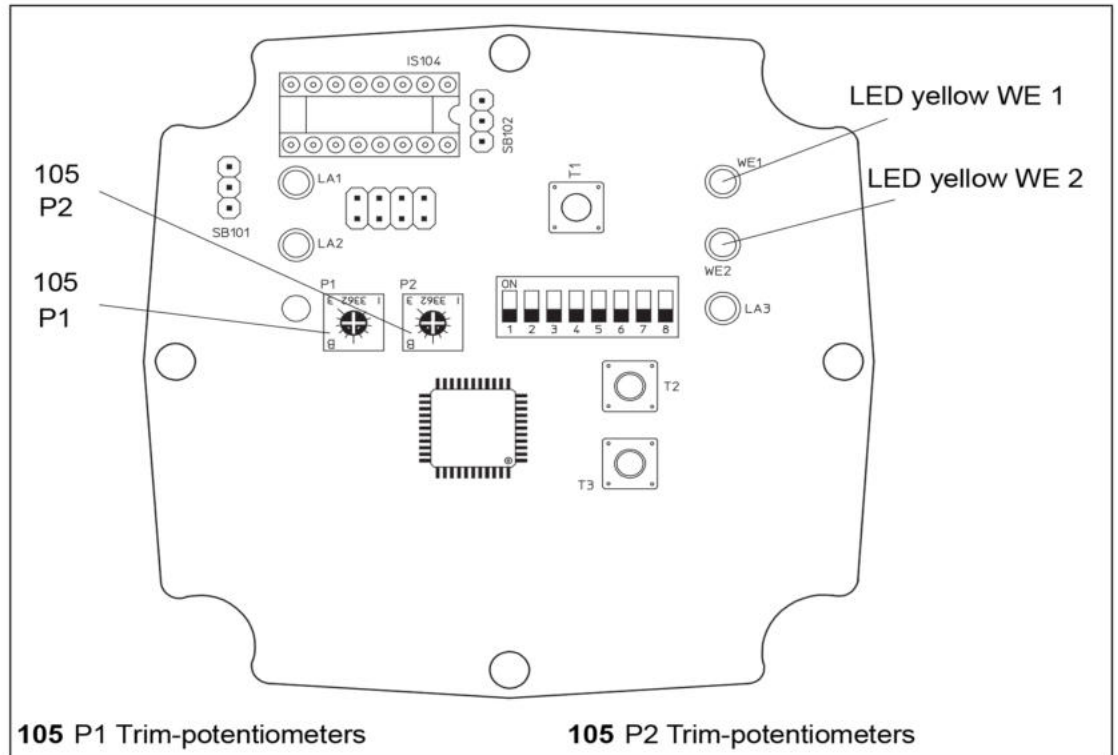

diagram 18 Control Board under the cover

- 5** Comply with the allowable contact load for the path switch:

Nominal load	8 A, 250 V AC 8 A, 30 V DC
Switch voltage	max. 400 V AC max. 125 V DC

table 7 Contact load of the path switch

- 6** Disconnect the actuator from the supply and connect the path switch contacts.
7 Close the cover (201.2) of the linear actuator
 ⇒ To replace the cover on page 15

5.7 Initialising the path measuring system



Linear actuator starts automatically!

The linear actuator starts immediately after being connected to the supply voltage and automatically moves to a reference point of the path measuring system. Wait until this reference point has been reached and the linear actuator has stopped.

The path measuring system has to be initialised after the following:

- At initial commissioning
- After repairs to the valve or actuator
- After a replacement of valve or actuator

Initialisation may be triggered in two different ways.

■ How to initialise via the initialising button



Risk of injury from electric shock by live parts!

When the supply voltage is turned on there is a risk of electric shock from live parts.

- Take care not to touch any live parts.
- Take care to apply the tool in a way that does not cause short-circuit.

- 1 Open the cover (201.2).
⇒ 4.4 Assembling/disassembling the cover on page 14
- 2 Make sure that the supply voltage is applied.
- 3 Press the initialization key (118) and hold it pressed it until the green LED at high frequency (about 10s-1) to flash (flicker) starts (about 2 seconds).

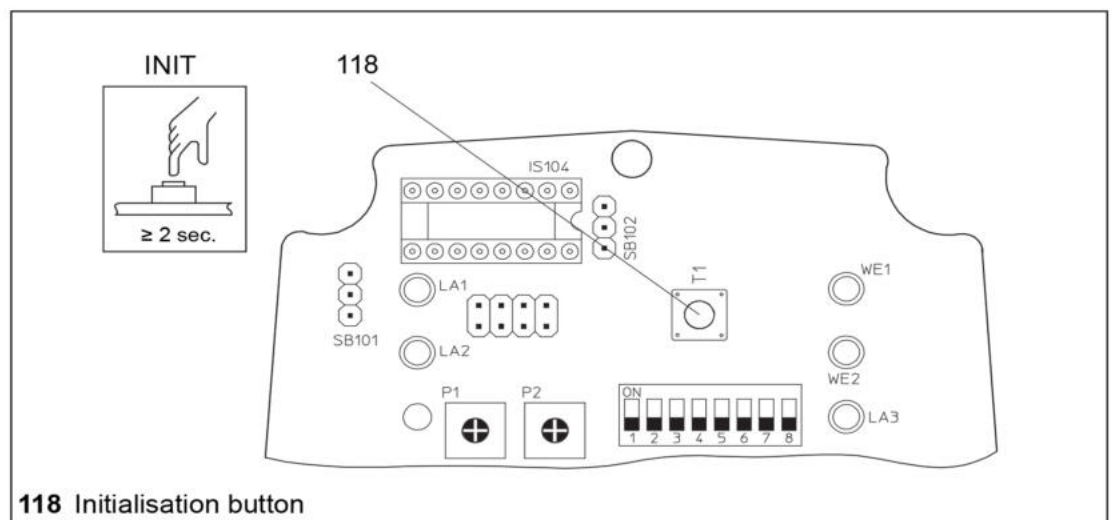

diagram 19 Initialize position measuring system

■ **To install on the terminals**

- 1 Insert the supply voltage simultaneously to terminals 2 and 3. Make sure that the supply voltage is applied for at least 2 seconds.

⇒ diagram 9 on page 18

The initialization procedure is indicated by the high-frequency (about 10s-1) flashing (flickering) LED.

During the installation process, the X signal is 0 and the function of the limit switch is inoperative.

After each initialization, the device is basically in steady operation.

5.7.1 Basic setting of position measuring system



The position measuring system has been calibrated at the factory before delivery. A readjustment is not usually required.

The following description is for information only to the user.

- 1 Bring the actuator spindle with position measuring system coupled to it into the maximum or minimum possible position. This can also be detected at the position of the pulley (position the cable crimping sleeve (A) Figure 20 on page 31).
- 2 Turn off the device and bring the red handle (39) from position AUTO into position MAN.
- 3 Press the button (T3) and hold it down.
- 4 turning the red handle (39) in the AUTO position. Then turn on the device by release the button (T3).
- 5 Insert the screwdriver (2mm) gently into the hollow shaft of the rotary encoder, the driving leg of the coil spring over it.
- 6 If you have fulfilled the angle of rotation sensor magnetic foil the slot, (Figure 20 on page 31), rotate until the green LED turns off and the LED lights up orange directly and vice versa. Prevent by holding the pulley from rotating the same. The optimal position is reached when both LEDs are flashing same time. Avoid higher axial pressure on the handle of the screwdriver to avoid pushing the angle of rotation sensor magnetic wave from its seat in the hollow shaft of the starter pulley.
- 7 Press the button (T2) to return to normal operation of the device (green LED and possibly orange LED lit).
 - If the device was previously in continuous mode, the orange LED lights up continuously.
 - If the device was previously in three-point mode, the orange LED turns off after a short time (about 3 sec.).

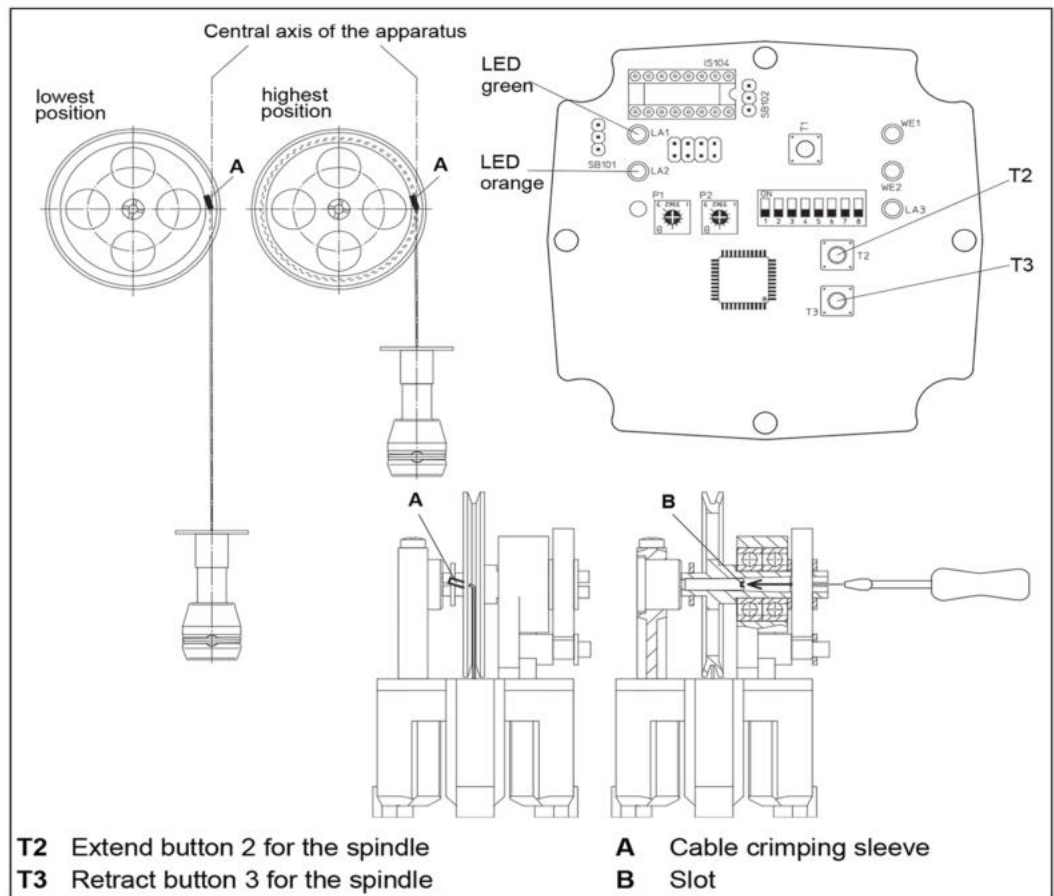

diagram 20 Basic setting of the position measuring system

5.8 Commissioning

- 1 Check whether all fitting and assembly work has been competently finished.
⇒ 4 Assembly on page 12
- 2 Ensure that the electrical actuation of the linear actuator can take place safely without putting people or devices at risk.
- 3 Ensure that the linear actuator is attached correctly and that the cover of the linear actuator is closed.
⇒ 4.4 Assembling/disassembling the cover on page 13/14
- 4 Ensure that the linear actuator is set to automatic mode.
⇒ 6.1 Changing between manual and automatic mode on page 29
- 5 Ensure that the operating parameters are set correctly.
⇒ 5.1 Operating parameters and coding switch positions on page 22
- 6 Ensure that the path measuring system is initialised.
⇒ 5.7 Initialising the path measuring system on page 26
- 7 Apply supply voltage. The linear actuator will now move to the reference point. The linear actuator is ready for operation.

Do not operate the actuator without fixed stops (eg valve).

There is a danger of a separation of distance measuring system and actuator spindle and a destruction of the bellows (particularly with extending drive the spindle).

6 Operation

Before using the linear actuator into operation, you need to initialize it, and select the operating mode.

- ⇒ 5 Commissioning on page 24
- ⇒ 5.7 Initialising the path measuring system on page 29

6.1 Changing between manual and automatic mode

It is possible to run the linear actuator in automatic mode or manual mode (manual adjustment).

- In automatic mode the spindle nut moves to the position set by the controller.
- In manual mode it is possible to set the spindle manually, e. g. for control purposes. Output signal (X) is not available in manual mode.

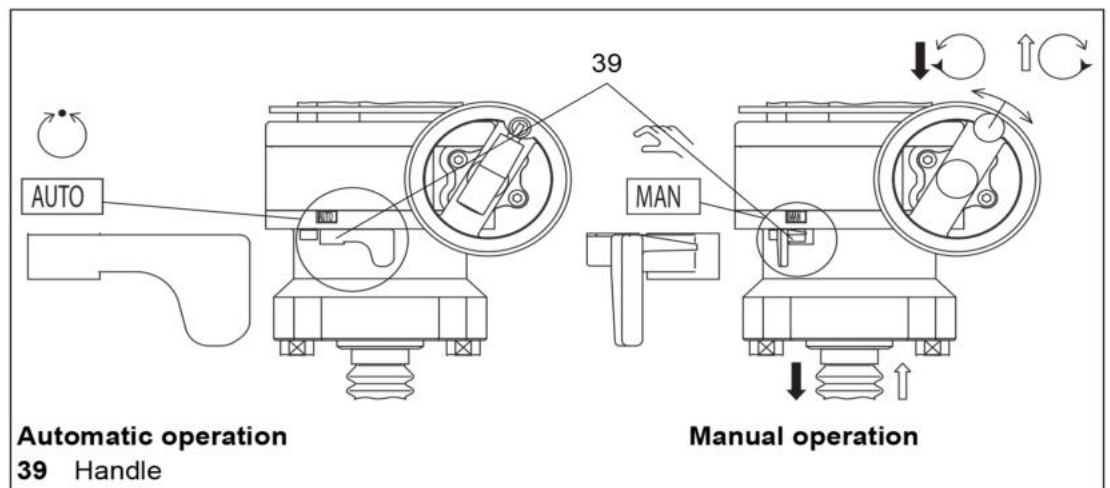

diagram 21 Switch to automatic mode

- **How to change-over in manual mode**
Insert the red handle (39) to position manual mode (MAN).
- **How to change-over in automatic-mode**
Insert the red handle (39) to position automatic mode (AUTO).

6.2 LED display

The LEDs on the viewing panel (47) show the operating status or errors.

⇒ 9 Decommissioning and disposal on page 35

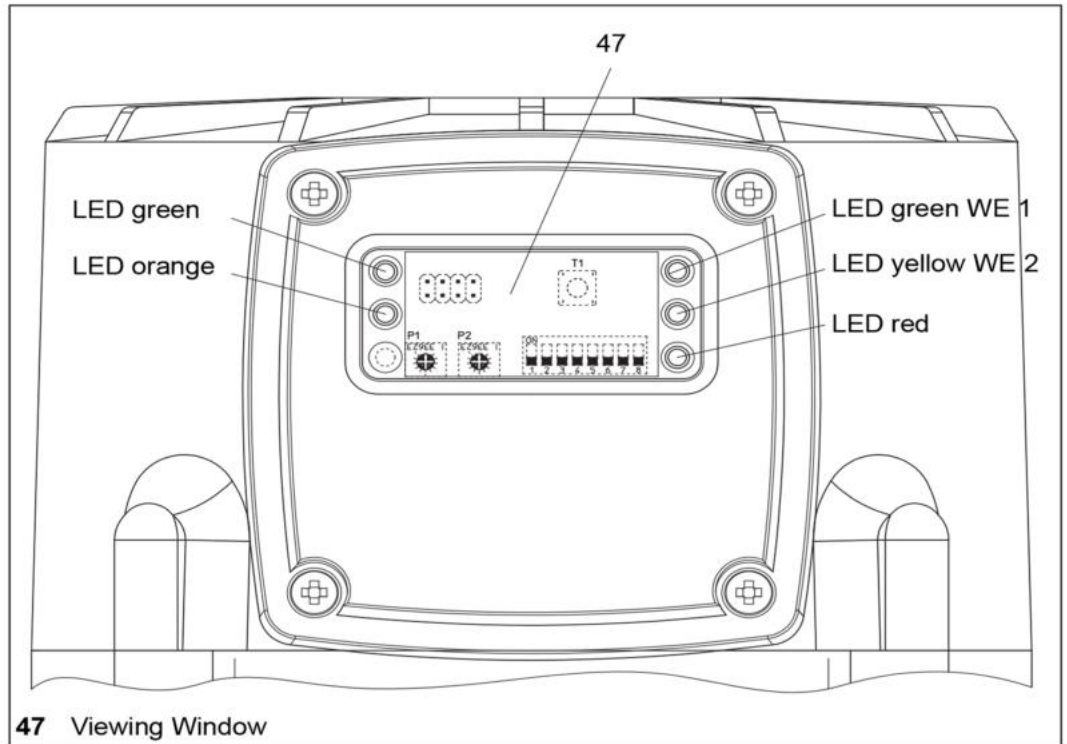

47 Viewing Window

diagram 22 LED-Display









Green LED	Operating status
 Continuously	Normal operation, standby The LED lights up continuously, actuator awaits drive command.
    0,3s 0,3s 0,3s 0,3s	Normal operation Drive executes operation commands.
    0,05s 0,05s 0,05s 0,05s	Initialization

table 8 Display green LED







Orange LED	Operating status
 Continuously	Continuous operation The LED lights up continusly
 off	Three-point operation The LED don't light up
    0,3s 0,3s 0,3s 0,3s	Binary incident The LED blinks with the green LED in unision

table 9 Display orange LED



Yellow LEDs	Operating status / error
 Continuously	Limit switch 1 Yellow LED W1 shows the switch condition (relay energized)
 Continuously	Limit switch 2 Yellow LED W2 shows the switch condition (relay energized)

table 10 Display yellow LED





Red LED	Operating status / error
    0,3s 0,3s 0,3s 0,3s	Wire break detection In the operating modes 2 ... 10 V or 4 ... 20 mA input signal drops below 1 V or below 2 mA. <i>2.4.2 Wire-break detection on page 9</i>

table 11 Display red LED

6.2.1 Light signals optional









LED green and orange	Operational status
    0,3s 0,3s 0,3s 0,3s     0,3s 0,3s 0,3s 0,3s	Local control active LEDs flash alternately.

table 12 Display green and orange LED

7 Maintenance, care and repairs

The linear actuator requires little maintenance. You need to perform a current or periodic maintenance. Thus, the driving spindle is greased sufficiently at any point, we recommend to drive the actuator once a day to an end position.

8 Spare parts

When ordering accessories and spare parts please quote the specifications engraved on the type plate of your linear actuator. The specifications on the type plate are standard for the technical date of linear actuators as well as the requirements for the public power supply.

Damage to device caused by faulty spare parts!

Spare parts must match the technical data specified by the manufacturer.

- Use genuine spare parts at all times.

⇒ 2.1 *Component parts* on page 6

⇒ 2.2 *Accessories* on page 7

9 Decommissioning and disposal

Dispose of the linear actuator according to national regulations and laws.

10 Removal of faults

After remedying faults you will have to re-initialise the path measuring system.

⇒ 5.7 Initialising the path measuring system on page 29

10.1 How to remedy faults

If the linear actuator does not work properly follow the sequence of operations described below in order to remedy the fault:

- 1 Check whether the linear actuator was correctly assembled.
- 2 Check the settings for the linear actuator against the specifications on the type plate.
- 3 Remedy the fault by following the check list.
⇒ 10.2 Check list for breakdown on page 36
- 4 If you are unable to remedy the fault contact the manufacturer.
- 5 For all queries at the manufacturer's and when sending back the device please quote the following :
 - SN (serial number = order number)
 - Type denomination
 - Supply voltage and frequency
 - Accessory equipment
 - Error report
- 6 If you are unable to remedy the fault despite inquiry you can send the device to the manufacturer.

10.2 Check list for breakdown

Fault	Cause/reason	Remedy
1. Linear actuator is not working.	Hand wheel (39) is in position manual mode	<input type="checkbox"/> Turn hand wheel (39) to position automatic mode.
	Power cut	<input type="checkbox"/> Determine cause and remedy.
	Fuse defective (in control cabinet)	<input type="checkbox"/> Determine cause and remedy, replace fuse.
	Linear actuator incorrectly connected	<input type="checkbox"/> Set connection correctly according to wiring diagram (on cover).
	Short circuit due to humidity	<input type="checkbox"/> Determine cause, dry the linear actuator; replace cover seal or screw joints and/or attach protective cover, as required.
	Short circuit due to incorrect connection	<input type="checkbox"/> Correct setting for connection
	Motor has winding damage (burnt-out) <ul style="list-style-type: none"> • e.g. voltage too high • Electronic system defective 	<input type="checkbox"/> Determine cause, measure current data, Compare to type plate and table, Disassemble linear actuator and send it in for repairs.
2. Linear actuator running unsteadily, i. e. veering between clockwise and anti-clockwise rotation.	Drop of voltage due to excessively long connecting cables and / or insufficient diameter.	<input type="checkbox"/> Measure the current data; if required, recalculate and replace connecting cables!
	Public power supply fluctuations greater than admissible tolerance ⇒ 2.5 <i>Technical data</i> on page 10	<input type="checkbox"/> Improve public power supply conditions
3. Linear actuator pauses intermittently or initialises frequently.	Slack contact in feeder line	<input type="checkbox"/> Check and tighten connections (terminal strips)
4. Linear actuator does not move to limit position. Valve does not open/close.	Valve is stuck	<input type="checkbox"/> Provide smooth-running valve
	Excessive system pressure	<input type="checkbox"/> Adjust system pressure
5. Linear actuator does not move at all or not correctly to the position preset by input signal Y .	Input signal Y is faulty: <ul style="list-style-type: none"> • Interfering signals • Signal variations 	<input type="checkbox"/> Check input signal Y on linear actuator, remove cause of fault
	Main PCB defective	<input type="checkbox"/> Replace main PCB or disassemble linear actuator and send it in for repair
6. Green LED is flashing in short/short rhythm.	Blockage detection was triggered	<input type="checkbox"/> Press INIT and observe actuator during initialisation.
		<input type="checkbox"/> Check valve for smooth-running along entire traverse range

table 13 Check list breakdown