

Operating Manual

Linear actuators

MLH220C • MLH220A • MLH223C • MLH223A

General information

Amendment	Version	Date	Modifications
	1.0	September 2021	Initial preparation

Copyright The copyright for this operating manual as well as all rights in case of patent awarding or registration of registered design remains with the manufacturer!

Subject to alteration The regulations, directives, standards etc. are compliant with the current state of information at the time of development and are not subject to modification service. They must be applied by the operator at his own responsibility in their latest valid version.

Concerning all data, information, and illustrations in this manual we reserve the right of technical modifications and improvements. No claims can be considered for alteration or rework of already delivered lift drives.

Table of contents

1 Safety	4	4 Assembly	12
1.1 Proper use	4	4.1 Checking the scope of delivery	12
1.2 Information for the operator	4	4.2 Preparing assembly	12
1.3 Personnel.....	5	4.3 Mounting the linear actuator on the valve	13
1.4 Prior to starting work.....	5	4.4 Assembling/disassembling the cover	15
1.5 During operation	5	4.5 Electrical connection	16
1.6 Working environment.....	5	4.5.1 Controller independent circuit.....	18
		4.5.2 Removing the PCB cover	19
2 Product Specification	6	4.6 Fitting accessories	20
2.1 Component parts	6	4.6.1 Fitting a PCB for a path switch	20
2.2 Accessories	7	4.6.2 Fitting the PCB for the mA output signal.....	21
2.3 Operating modes	7	5 Commissioning	24
2.3.1 Continuous mode	7	5.1 Operating parameters and encoding switch settings .	25
2.3.2 Three-point mode	8	5.2 Setting the input signal.....	25
2.4 Functions	8	5.3 Setting the hysteresis.....	25
2.4.1 Binary signal / frost protection function.....	8	5.4 Setting the actuating direction.....	25
2.4.2 Blockage detection	8	5.5 Setting auto test and auto pause	26
2.4.3 Wire break detection.....	8	5.6 Setting the limit position	27
2.4.4 Actuating time.....	9	5.7 Setting a potential-free path switch	27
2.4.5 Hysteresis.....	9	5.8 Initialising the path measuring system	29
2.4.6 Manual mode and response signal.....	9	5.9 Commissioning.....	30
2.4.7 Auto test	9	6 Operation	31
2.4.8 Auto pause	9	6.1 Changing between manual and automatic mode...31	
2.4.9 Potential-free limit switch (accessory)	9	6.2 LED display	32
2.5 Technical data	10	7 Maintenance, care and repairs	32
2.6 Type plate	11	8 Spare parts	32
3 Transportation & Storage	11	9 Decommissioning and disposal	33
		10 Removal of faults	33
		10.1 How to remedy faults	33
		10.2 Check list for breakdown.....	34

1 Safety

Read these Operating Instructions carefully particularly the following safety instructions prior to installation and operation.



DANGER

Directly threatening hazard leading to death or serious physical injuries.



WARNING

Potentially hazardous situation which may lead to death or serious physical injuries.



CAUTION

Potentially hazardous situation which could lead to minor physical injuries. Indicates a hazard which may cause material damage.



ATTENTION

Potentially hazardous situation where the product or an object in its environment may get damaged.

Hint: Utilisation instructions and other useful information.

1.1 Proper use

Linear actuators MLH220C - MLH220A - MLH223C - MLH223A are controlled by three-point control or constant control. Linear actuators in the series described in these Operating Instructions are used for valve stroke adjustment.

Concurrence of the above type designation with the linear actuator rating plate must be checked prior to starting any operations in order to guarantee utilisation in accordance with specification. The data on the rating plate is decisive for linear actuator technical data and mains power supply requirements.

Any utilisation for tasks other than the aforementioned usage in accordance with specification and operating with mains power supply ratios other than those permitted is not deemed to be utilisation in accordance with specification. The operator bears sole liability for the risk to persons and machine and other assets in the event of utilisation not in accordance with specification.

The intended use also includes the compliance with accident preventions, DIN VDE regulations and safe working practices for all measures described in these operating instructions in due consideration of prevailing rules.

1.2 Information for the operator

Always keep the Operating Instructions available at the linear actuator deployment site.

Observe the current health and safety, accident prevention and DIN VDE standards for installation, operation and maintenance.

Take into consideration any additional regional, local or in-house safety regulations.

Ensure that every person entrusted with one of the tasks specified in these Operating Instructions has read and understood these instructions.

1.3 Personnel

Only qualified personnel may work on these linear actuators or in their vicinity. Qualified persons are those persons entrusted with installation, assembly, commissioning and operation or maintenance of the linear actuators and possessing the appropriate qualifications for their activity. The necessary and prescribed qualifications include:

- Training / instruction or authorization to turn on /off circuits and appliances / systems according to EN 60204 (DIN VDE 0100 / 0113) and the standards of safety technology.
- Training or instruction according to the standards of the safety technology concerning care and use of adequate safety and work protection equipment.
- First Aid training.

Work in a safe manner and refrain from any working practice which endangers the safety of persons or damages the linear actuator or other assets in any way whatsoever.

1.4 Prior to starting work

Prior to starting any work, check that the type designations specified here concur with the data on the linear actuator rating plate.

Linear actuators MLH220C - MLH220A - MLH223C - MLH223A.

1.5 During operation

Safe operation is only possible if transportation, storage, installation, operation and maintenance are carried out safely and materially and professionally correctly.

Transportation, installation and assembly

Observe the general set-up and safety regulations for heating, ventilation, air-conditioning and pipework design. Use tools correctly. Wear the necessary personal and other safety equipment.

Repairs and maintenance

Ensure that qualified personnel switch off the linear actuator prior to maintenance or repair work in accordance with DIN VDE.

1.6 Working environment

Read the data concerning the working environment in the Technical Data.

2 Product Specification

The linear actuators control a stepper motor by means of a micro controller. The stepper motor's rotational movement is converted into a linear movement via planetary gears and a threaded spindle with rotary gurad.

2.1 Component parts

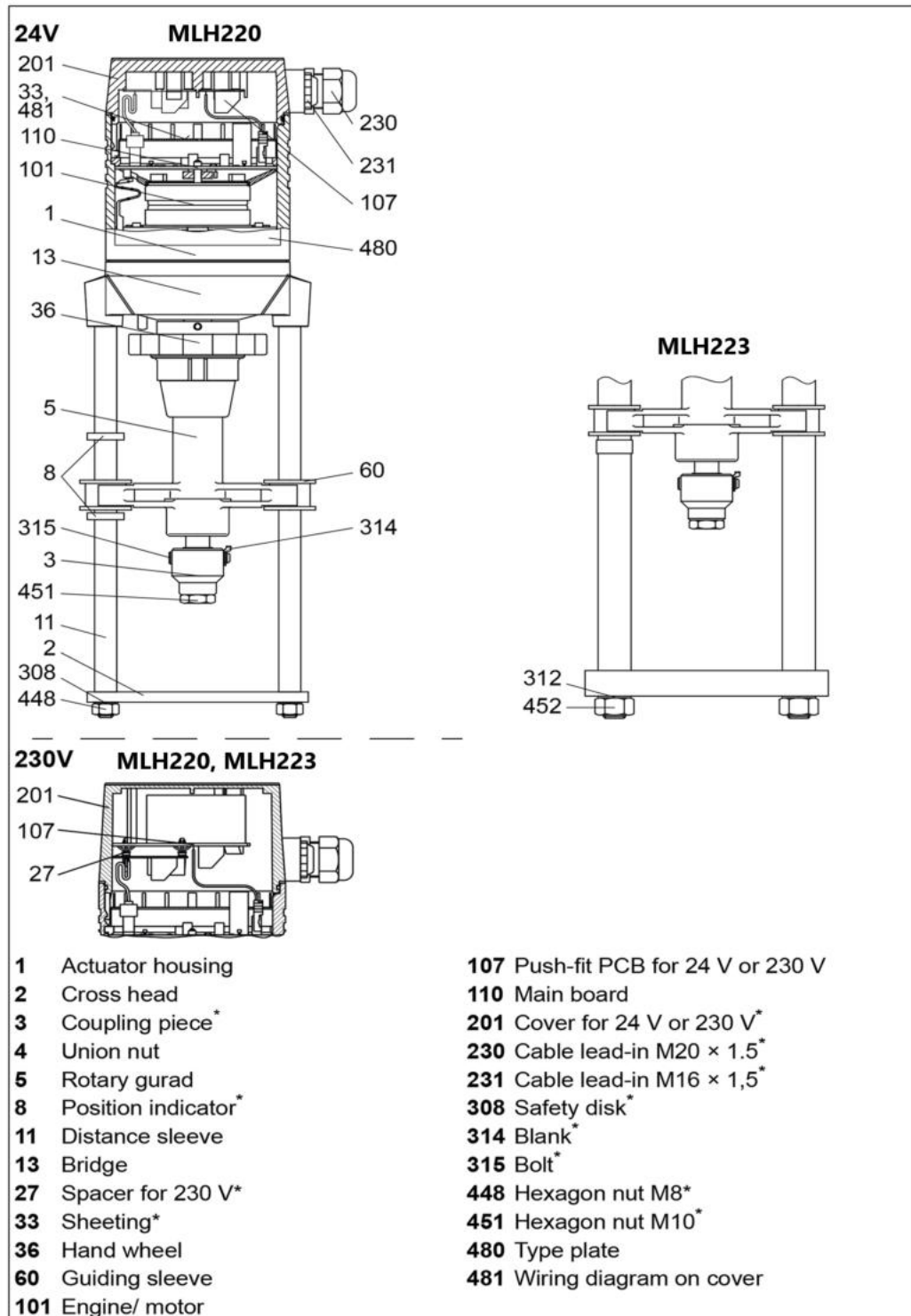

diagram 1 Component part denominations

* This component part is available as a spare part!

2.2 Accessories

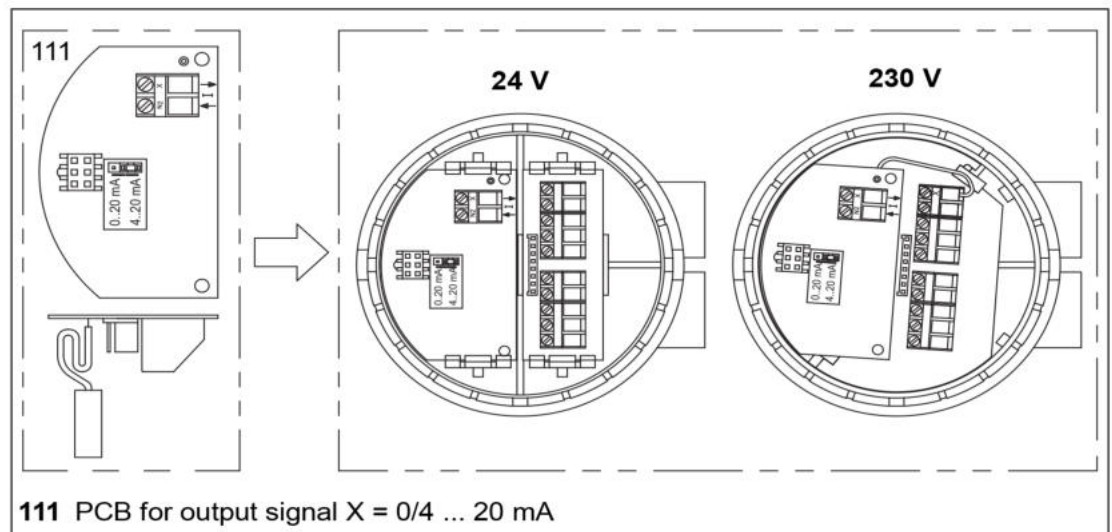

diagram 2 PCB for mA output signal in cover

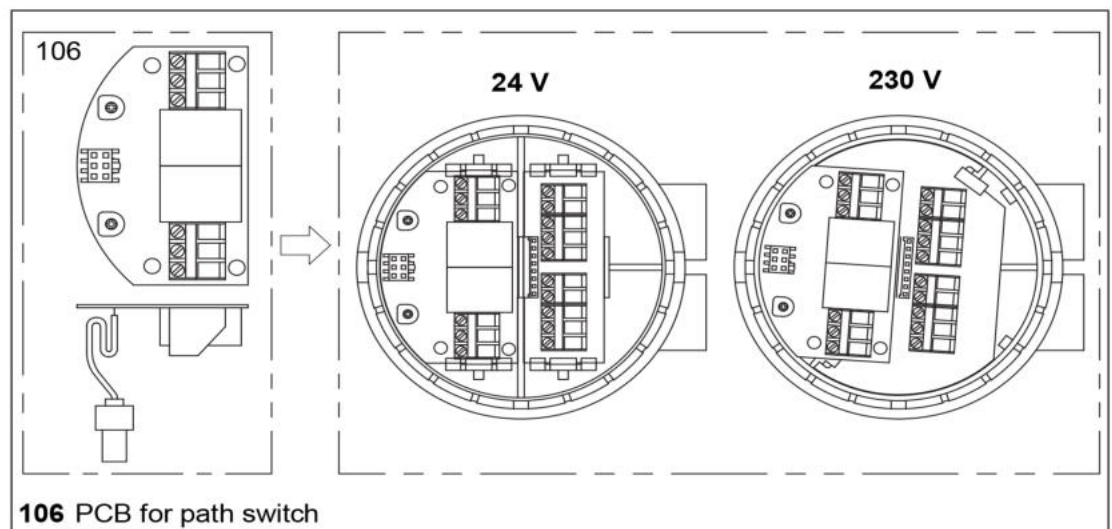

diagram 3 Position switch PCB in cover

Hint: Optional operation with mA output signal or path switch possible

2.3 Operating modes

The linear actuator can be operated manually or automatically.

- In manual mode stroke is adjusted via the hand wheel.
- In automatic mode stroke is controlled electrically.

2.3.1 Continuous mode

In continuous mode the system control presets the position of the linear actuator whilst inside the linear actuator the input signal (Y) of the system control is continuously compared with the output signal (X) of the linear actuator. In doing so the output signal depends on the position of the linear actuator (travel).

The linear actuator keeps moving until the input signal and the output signal match.

Input signal (Y) The input signal (Y) of the system control specifies the desired position for the linear actuator. It is applied in the form of an analogue signal to terminal Y.

Possible input signals:

- 0 ... 10 V DC / 2 ... 10 V DC
- 0 ... 20 mA / 4 ... 20 mA

Output signal (X) The output signal (X) determines the actual position of the linear actuator. It is applied to terminal X in the form of an analogue signal.

0% to 100% valve lift is put out as:

- 0 ... 10 V DC
- 0 ... 20 mA or 4 ... 20 mA (accessory PCB for output signal (111))

2.3.2 Three-point mode

The direction of rotation is set via the control voltage at terminal 2 and terminal 3 on the main PCB:

- When the control voltage is applied to terminal 2, the rotary gurat will be extended.
- When the control voltage is applied to terminal 3, the rotary gurat will be retracted.

2.4 Functions

2.4.1 Binary signal / frost protection function

The terminals B1 and B2 on the main PCB are bridged during normal operation. If the electric circuit between B1 and B2 is interrupted, the linear actuator will store the current position and afterwards move automatically to its limit position.

All other control signals will be ignored during this process.

The linear actuator will remain in limit position until the electric circuit between B1 and B2 has closed.

- In three-point mode the linear actuator will automatically return to the stored position.
- In continuous mode the desired value of the input signal will be restarted.

2.4.2 Blockage detection

If the linear actuator is blocked manually, the linear actuator will briefly move back and then retry to reach the required position. If this is still unsuccessful after a total of 7 attempts the linear actuator will be turned off in order to prevent damage to the linear actuator and the control element.

Blockage detection is indicated by LED

⇒ 6.2 LED display on page 31

2.4.3 Wire break detection

Wire break detection is only available for continuous mode with an input signal 2 ... 10 V DC and 4 ... 20 mA.

When the input signal drops below 1 V or 2 mA in continuous mode the linear actuator will move to the limit position set by encoding switch S6.

Wire break detection is indicated by the LED.

⇒ 6.2 LED display on page 31

2.4.4 Actuating time

The time required for the rotary guard to travel a defined distance is called actuating time. Actuating time is specified in s/mm.

2.4.5 Hysteresis

Hysteresis equals the difference of the input signal (Y) that is required after a reversal of signal direction in order to move the rotary guard.

It serves to prevent permanent oscillation of the actuator motor around a certain hoisting position during minor input signal alterations.

⇒ 5.3 *Setting the hysteresis* on page 24

2.4.6 Manual mode and response signal

In manual mode it is possible to change the lift without supply voltage.

- Motor and control electronics are turned off in manual mode to make hoisting movements of the control impossible.
- The moment you set the linear actuator to manual mode the control switches a signal to terminal R, provided supply voltage is applied.

⇒ 6.1 *Changing between manual and automatic mode* on page 30

2.4.7 Auto test

If a valve is not actuated for a long time the valve cone may get stuck. The auto test function acts as a preventative measure. When you turn on the auto test function for the linear actuator, the linear actuator will automatically move after c. 10 days without actuation to the limit position set by encoding switch S6 and return to initial position.

⇒ 5.5 *Setting auto test and auto pause* on page 25

2.4.8 Auto pause

This function is used by the actuator to count the traverse commands per minute that involve a change of direction. If there are more than 20 direction varying traverse commands per minute this will result in a compulsory pause of 3 s.

⇒ 5.5 *Setting auto test and auto pause* on page 25

2.4.9 Potential-free limit switch (accessory)

The optional path switch PCB allows you **(106)** to set two actuating positions within which a potential-free contact is opened or closed.

⇒ 5.7 *Setting a potential-free path switch* on page 26

2.5 Technical data

Type	MLH220C, MLH223C	MLH220A, MLH223A
Supply voltage:	24 V AC \pm 10% 24 V DC \pm 10%	115 V AC \pm 10% 230 V AC \pm 10%
Power consumption	6 VA	12 VA
Weight	MLH220= 3.2 kg MLH223= 4.0 kg	MLH220= 3.2 kg MLH223= 4.0 kg
Dimensions	See technical data sheets	
Stroke	MLH220= max. 30 mm MLH223= max. 30 mm	MLH220= max. 30 mm MLH223= max. 30 mm
Frequency	50/60 Hz \pm 5%	50/60 Hz \pm 5%
Ambient temperature	0 to +60°C	0 to +60°C
Enclosure protection	IP 54	IP 54
Operating mode	S3-50% ED	S3-50% ED
Actuating time	3 s/mm	3 s/mm
Actuating force	2,2 kN During 24 V DC the specified actuating force can only be reached with the help of an aligned AC voltage.	2,2 kN

table 1 Technical data

Input signal Y/ Resistance of load	<ul style="list-style-type: none"> • 0 ... 10 V DC / 77 kΩ • 2 ... 10 V DC / 77 kΩ • 0 ... 20 mA / 510 Ω • 4 ... 20 mA / 510 Ω
Output signal X/ Load rating	<ul style="list-style-type: none"> • 0 ... 10 V DC / resistance of load \geq 1200 Ω, I_{max}. 8 mA • 0 ... 20 mA / resistance of load \leq 500 Ω - with accessory PCB for output signal (111) • 4 ... 20 mA / resistance of load \leq 500 Ω - with accessory PCB for output signal (111)
Response signal R/ load rating	• 24 V DC / minimum impedance \geq 480 Ω / I_{max} . 35 mA
Cable impedance between B1 and B2	• max. 10 Ω

table 2 Technical data signals

2.6 Type plate

The type plate is attached to the housing of the linear actuator.

It bears the type denomination, serial number (s/no) and date of manufacture (last four digits).

⇒ 2.1 Component parts on page 6

		
MLH220C		
F.-Nr.: 07204142/01/0607		
AC 50 Hz 24 V	6 VA	2,2 kN
Y=0...10 V DC	IP 54	3 s/mm
X=0...10 V DC	S3-50% ED	Stroke 14 mm

diagram 4 Example of type plate

3 Transportation & Storage



Non-compliance with safety regulations may result in injury!

- Wear the required personal and other safety equipment.
- Avoid impacts, blows, vibrations etc. to the linear actuator.
- Store the linear actuator (and, where appropriate, the entire controlling device) in a dry place.
- Keep to the specified transport and storage temperatures between -20 to +65°C.

4 Assembly

Prior to assembling the linear actuator:

⇒ 4.1 *Checking the scope of delivery* on page 12

⇒ 4.2 *Preparing assembly* on page 12

The following sequence of operations is part of the linear actuator assembly:

⇒ 4.3 *Mounting the linear actuator on the valve* on page 13

⇒ 4.4 *Assembling/disassembling the cover* on page 15

⇒ 4.5 *Electrical connection* on page 16

4.1 Checking the scope of delivery

- 1 Check the packaging for damage.
- 2 Dispose of packaging in an environmentally friendly manner.
- 3 Check the delivered items against the delivery note in order to see whether the delivery is complete.
- 4 Report any missing or damaged products to the manufacturer.

4.2 Preparing assembly

A non-attached valve causes damage!

ATTENTION

If you operate the linear actuator without valve, the rotary guard may fall off due to the missing stop.

- Always operate the linear actuator with a valve attached.

- 1 Allow for about 140 mm space above the cover at the site of installation.
- 2 Check the working environment before assembling and commissioning the linear actuator:
- 3 Ensure that the valve is correctly fitted. For details please see assembly instructions for valve.
- 4 Determine the assembly position of the linear actuator. Do not arrange linear actuators in a hanging position.

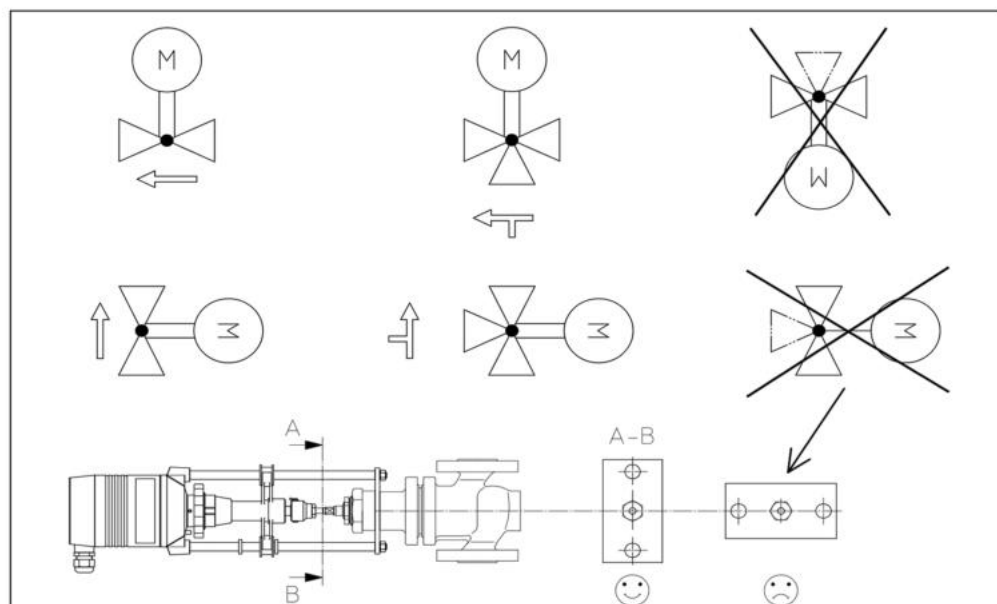

diagram 5 Assembly positions for linear actuator and valve

4.3 Mounting the linear actuator on the valve

If the linear actuator and the valve are supplied separately you will have to mount the linear actuator on the valve.

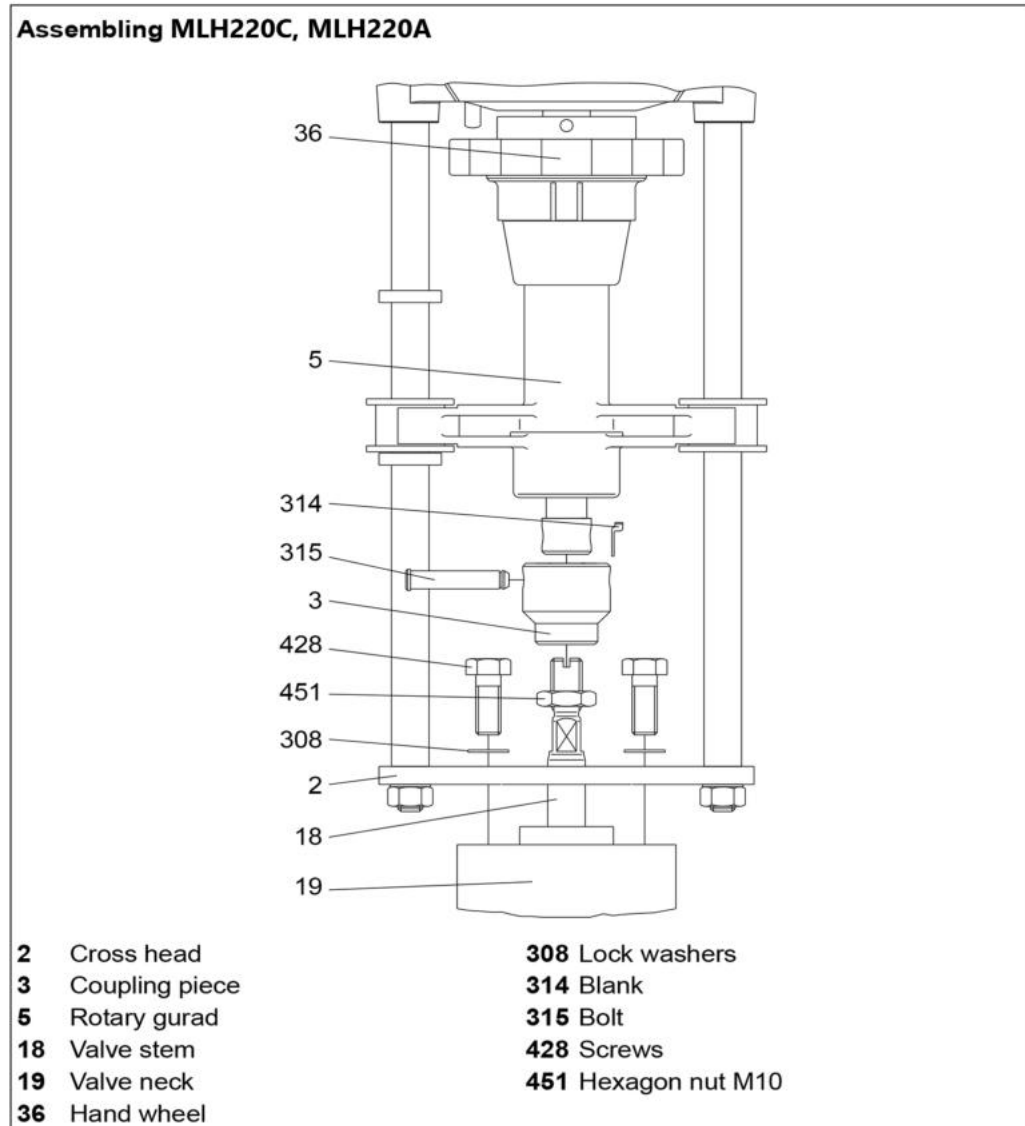
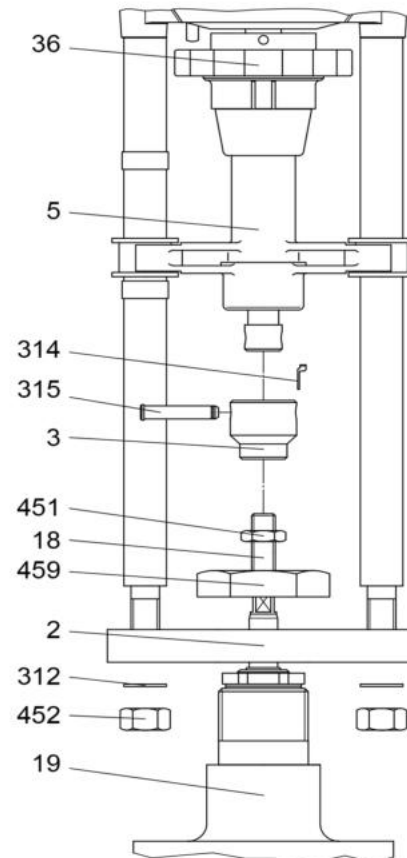

diagram 6 Mounting the linear actuator on the valve

■ How to assemble linear actuator type MLH220

- 1 Pull off the blank (314).
⇒ *diagram 6* on page 13
- 2 Pull out the bolt (315) from the clutch piece (3) or drive it out.
- 3 Screw the hexagon locknut M10 (451) spanner width 17 onto the valve stem (18).
- 4 Screw the clutch piece (3) onto the valve spindle (18).
- 5 Place actuator with crossbeam (2) on valve neck (19).
- 6 Attach the crossbar (2) of the actuator with the help of screws (428) spanner width 13 and blanks (308) to the valve neck (19).
- 7 Adjust the height of the rotary gear (5) with the help of the hand wheel (308) so that you can remount the bolt (315).
- 8 Fit on the blank (314)!

- 9 Fix the valve stem (18) by the hexagon locknut (451), in order to prevent skewing.
- **How to disassemble the linear actuator**
- 1 Follow the sequence of operation in reverse order.

Assembling MLH223C, MLH223A

2	Cross head	312	Lock washers
3	Coupling piece	314	Blank
5	Rotary gear	315	Bolt
18	Valve stem	451	Hexagon nut M10
19	Valve neck	452	Hexagon nut M12
36	Hand wheel	459	Hexagonal nut

diagram 7 Mounting the linear actuator on the valve

■ **How to assemble linear actuator type MLH223 :**

- 1 Pull off the blank (314).
⇒ *diagram 7* on page 14
- 2 Pull out the bolt (315) from the clutch piece (3) or drive it out.
- 3 Screw the hexagon locknut M10 (451) spanner width 17 onto the valve stem (18).
- 4 Screw the clutch piece (3) onto the valve spindle (18).
- 5 Place the cross beam (2) and the hexagon nut (459) onto the valve neck (19).
- 6 Fix the crossbeam (2) with the hexagon nut (459) using a spanner width 50.
- 7 Place the actuator with distance sleeves onto the cross beam (2).
- 8 Fix the actuator by means of lock washers (312) and hexagonal nuts (452).

- 9 Adjust the height of the rotary gurald (5) with the help of the hand wheel (36) so that you can remount the bolt (315).
- 10 Fit on the blank (314)!
- 11 Fix the valve stem (18) with the hexagon locknut (451), in order to prevent skewing.

■ **How to disassemble the linear actuator**

- 1 Follow the sequence of operation in reverse order.

4.4 Assembling/disassembling the cover

The cover contains the terminals for electric connection.



Risk of injury from electric shock by live parts!

When the power supply is on there is a danger of electric shock due to live parts.

- Prior to commencing any work, ensure that the actuator is safely disconnected from the power supply system.
- Secure against unauthorised restarting.
- Remove the cover only momentarily.

■ **How to remove the cover**

- 1 Insert a screwdriver in the notch of the cover and lift the cover (201).

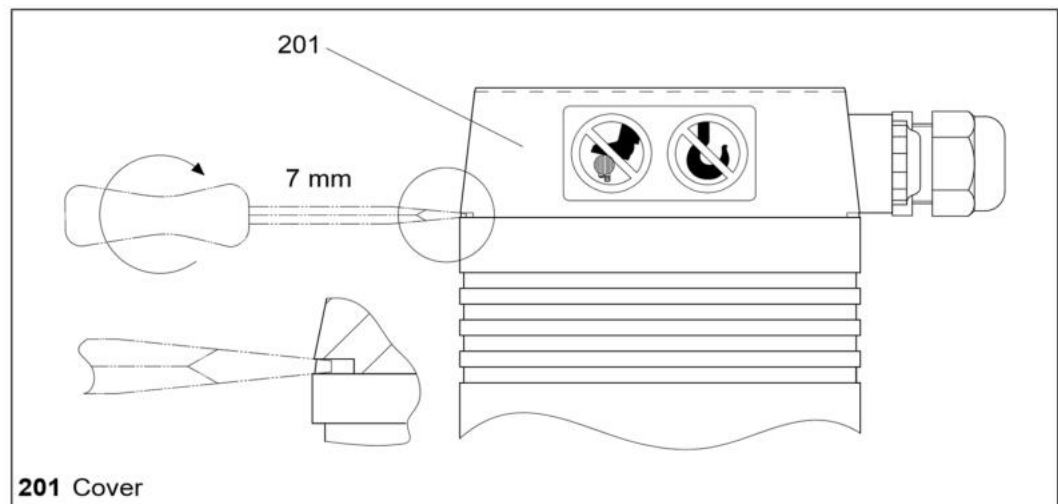

201 Cover
diagram 8 Removing the cover

Damaged cables result in damage to devices!

ATTENTION

When lifting the cover you may tear off or damage the cabling inside the cover.

- Carefully remove the cover.

- 2 Remove the cover (201) carefully.
- 3 Disconnect the plug-in connection between the main PCB and the (110) cover (201).

■ **How to attach the cover**

- 1 Plug the previously pulled off cables back into the main PCB (110).
Pay attention to the notches on plug and socket.

Hint: You can mount the cover **(201)** in four, different, positions each of which is transposed by 90°. This allows the best possible laying of the connecting cable for different installations of the linear actuator.

- 2 Place the cover **(201)** on top and push it down to make it fit by applying moderate force.
- 3 Check the cover for correct fit to ensure air-tightness for the actuator housing.

4.5 Electrical connection



Danger of life caused by incompetent staff!

Electrical connections carried out by unqualified staff may result in death, severe bodily injury or considerable material damage.

- Make sure that such all work is carried out by qualified staff.

⇒ 1.3 *Personnel* on page 5



Risk of injury from electric shock by live parts!

When the supply voltage is turned on there is a risk of electric shock from live parts.

- Prior to commencing any work, ensure that the actuator is safely disconnected from the power supply system.
- Secure against unauthorised restarting.

■ **How to prepare the electric connection**

- 1 Ensure that the supply voltage matches the specifications on the type plate of the linear actuator.
- 2 To avoid breakdown, construct the line diameter according to actuating performance and required line length.
- 3 Lay the mains for a supply voltage of > 48 V separate from the signal and control wires.

When laying cables in a joint cable duct, use shielded control wires.

- 4 Check the supply voltage.

If the required tolerance is not achieved by a power transformer you will have to use an AC voltage stabilizer.

⇒ 2.5 *Technical data* on page 10

■ **How to establish electrical connection**

- 1 Remove the cover (201).
⇒ *How to remove the cover* on page 15
- 2 Run the cable through the screw joint in the cover to the terminal.
- 3 Connect the power supply according to the wiring diagram.
⇒ *diagram 9* on page 17

Hint: The wiring diagram (481) is on the PCB cover(33).

ATTENTION

Malfunctions caused by incorrect zero potential!

If the electric power supply for the linear actuator is fed by transducing sensors with varying zero potentials this may result in incorrect automatic controller action.

- Ensure that the zero potential is properly applied.

⇒ *table 3* on page 18

- 4 Tighten the screw joints.

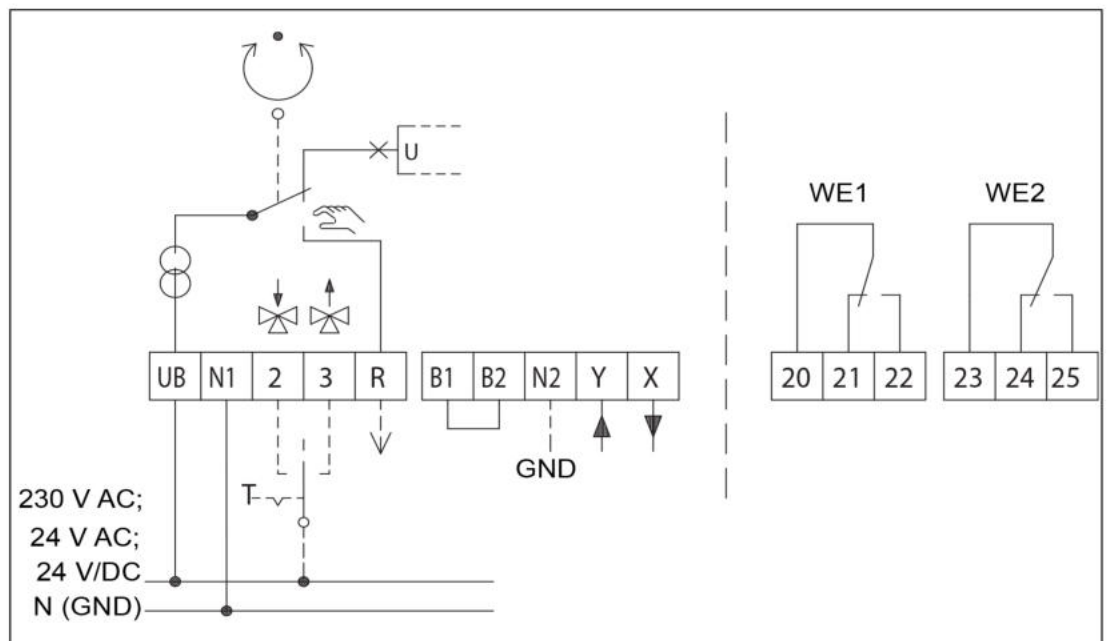

diagram 9 Circuit diagram

Terminal	Description
UB, N1	Supply voltage:
2	Control voltage for downward movement during three-point mode
3	Control voltage for upward movement during three-point mode
R	Response signal during "manual" mode • R= 24 V DC max. 35 mA
B1, B2	Binary input / frost protection function
N2	Zero potential of signals X, Y and R • When the zero potentials of signals X, Y and R are identical to the zero potential of the supply voltage it is possible to bridge terminals N1 and N2. • If you run the actuator in continuous mode at 230 V you will have to connect N2. • If you run the actuator in three-point mode at 230 V you will have to connect N2 if you wish to use X or R at the same time.
Y	Input signal continuous mode
X	Output signal continuous mode
20, 21, 22	Terminals path switch unit PS1
23, 24, 25	Terminals path switch unit PS2

table 3 Key to wiring diagram

4.5.1 Controller independent circuit

When working with 24 V supply voltage and 0 ... 10 V DC / 2 ... 10 V DC input signal you can switch the actuator controller-independently via a three-step toggle switch in the control cabinet.

■ **How to switch the actuator controller-independently**

- 1 Run the supply voltage 24 V AC via a diode and a three-step toggle switch to terminal Y.

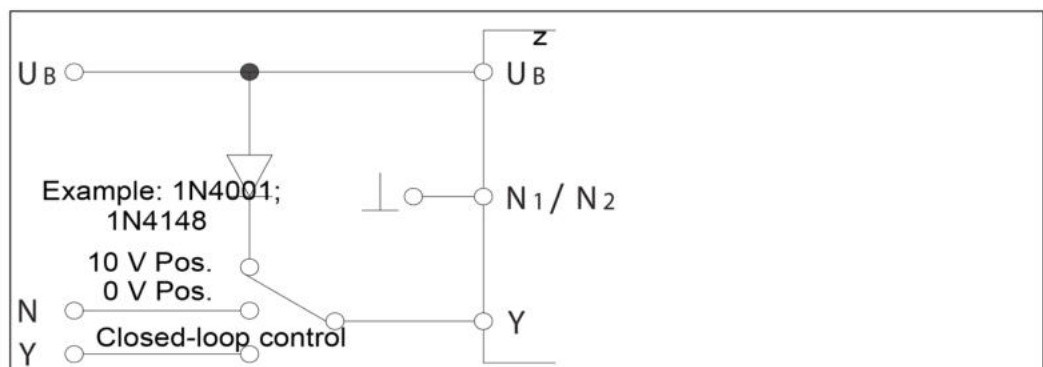

diagram 10 Controller independent circuit

- 2 Using the toggle you can move the linear actuator to the following positions:
 - Closed-loop control by input signal Y (normal operation)
 - 10 V-position
 - 0 V-Position, the linear actuator can be moved to the position selected by encoding switch S6 at 2 ... 10 V DC.
- ⇒ 5.1 Operating parameters and encoding switch settings on page 24
⇒ 5.6 Setting the limit position on page 26

4.5.2 Removing the PCB cover

To set the linear actuator by using the encoding switch you will first have to remove the PCB cover. **(33)**



Risk of injury from electric shock by live parts!

When the power supply is on there is a danger of electric shock due to live parts.

- Prior to commencing any work, ensure that the actuator is safely disconnected from the power supply system.
- Secure against unauthorised restarting.

- 1 Insert the screwdriver in one of the notches on the cover **(201)** and lift off the cover **(201)**.
- 2 Insert a small screwdriver in the designated notch on the printed circuit cover **(33)** and lift it off.

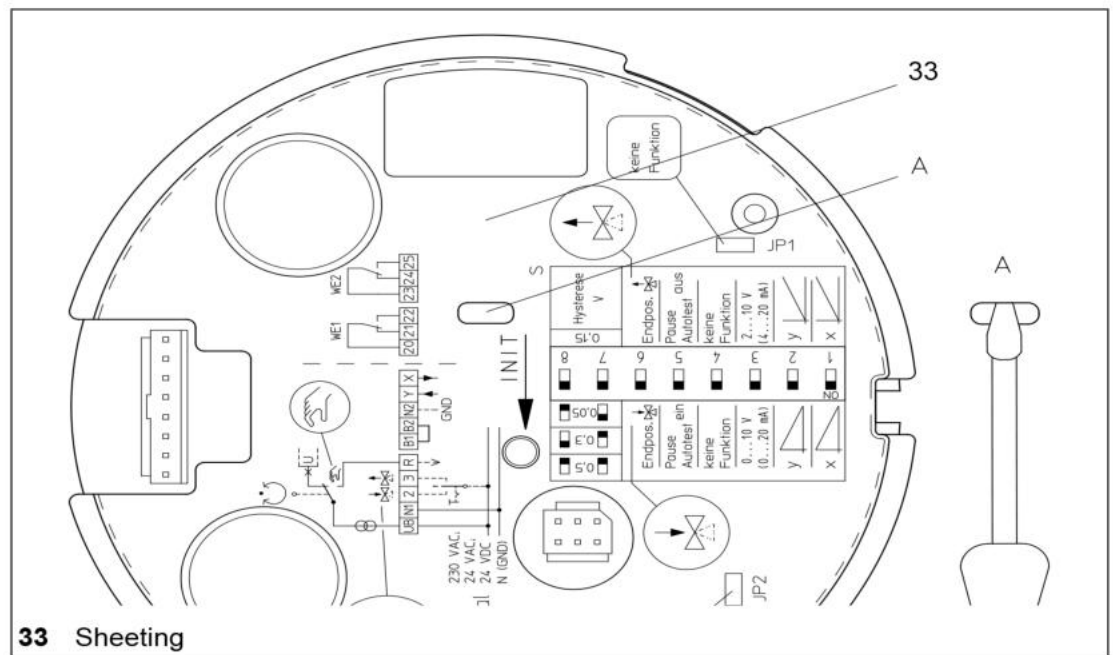

diagram 11 Remove the PCB cover in the actuator housing

- 3 Access to encoding switches S1 to S8 as well as jumpers JP1 and JP2 is achieved by removing the PCB cover **(33)** in the actuator casing **(1)**.

4.6 Fitting accessories

Accessories are not part of the scope of delivery for the linear actuator unless expressly ordered! The linear actuators are prepared for retro-fitting with:

- PCB for path switch **(106)**
- PCB for output signal $X=0/4 \dots 20 \text{ mA}$ **(111)**

Hint: Optional operation with mA output signal or path switch possible
⇒ 2.2 Accessories on page 7

4.6.1 Fitting a PCB for a path switch



Risk of injury from electric shock by live parts!

When the power supply is on there is a danger of electric shock due to live parts.

- Prior to commencing any work, ensure that the actuator is safely disconnected from the power supply system.
- Secure against unauthorised restarting.

- 1 Open the cover **(201)** of the linear actuator.
⇒ 4.4 Assembling/disassembling the cover on page 15
- 2 **24 V:** Clipping the path switch PCB **(106)** to the safety catches on the cover **(201)**
diagram 12 on page 20.
- 3 **230 V:** Push the path switch PCB **(106)** onto the three spacers of **(27)** the push-fit PCB **(107)**.

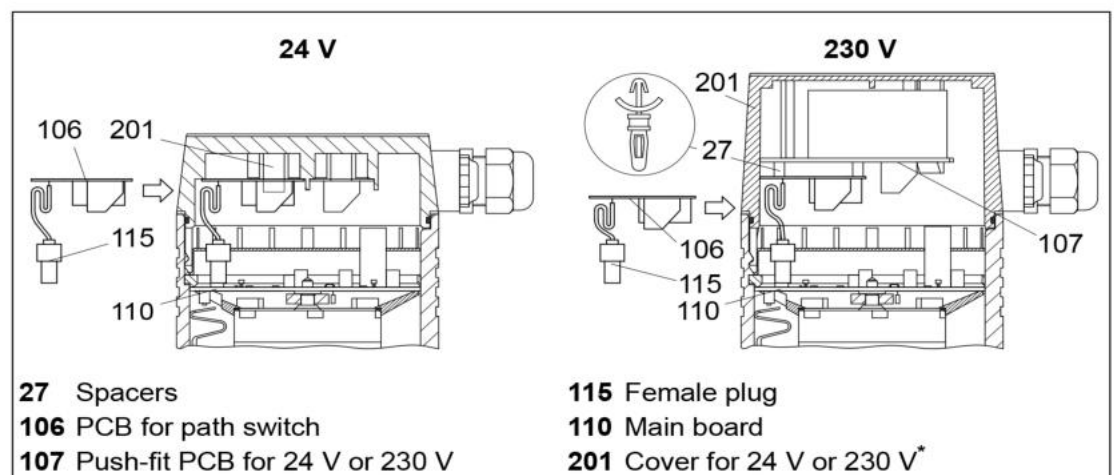
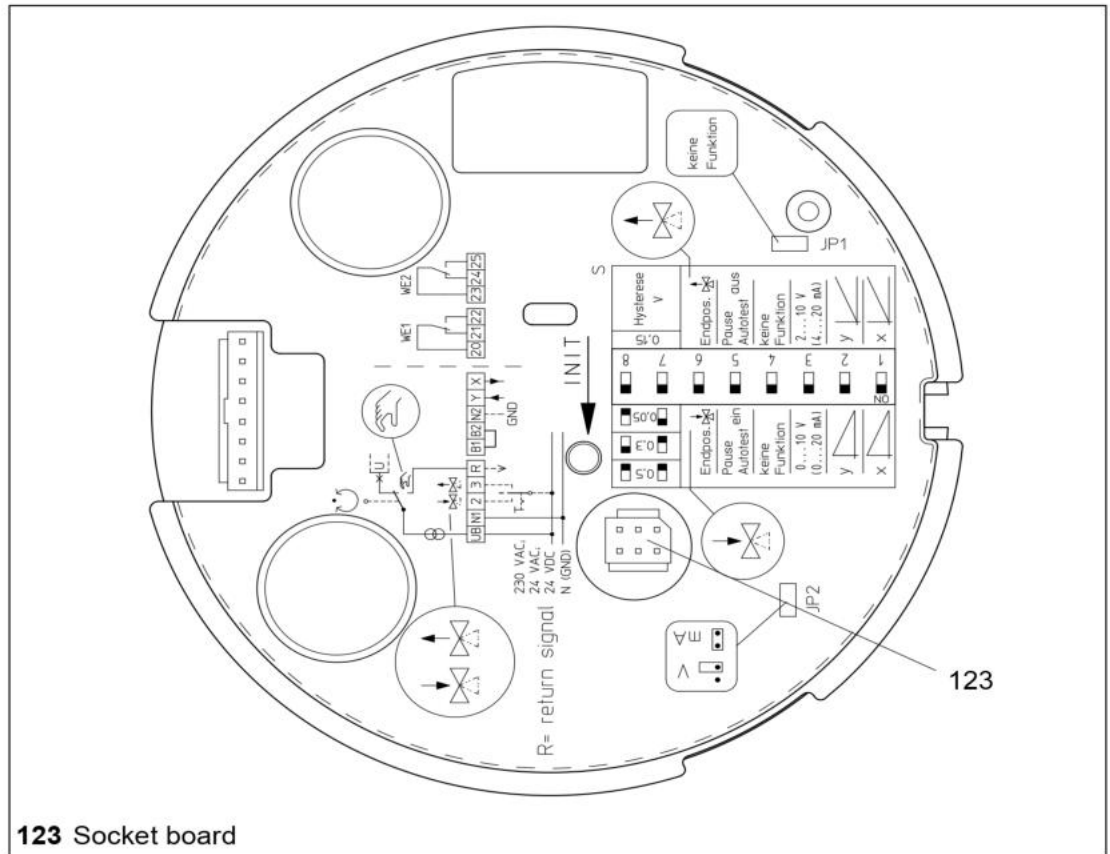

diagram 12 Assembling the path switch PCB inside the cover

- 4 Plug the female plug into the **(115)** path switch PCB **(106)** on the socket board **(123)** of the main PCB **(110)**. In the process pay attention to the notches on the socket board and female plug.



123 Socket board

diagram 13 Socket board for position switch PCB on main PCB

- 5 Set the position switches.
⇒ 5.7 Setting a potential-free path switch on page 26

4.6.2 Fitting the PCB for the mA output signal



Risk of injury from electric shock by live parts!

When the power supply is on there is a danger of electric shock due to live parts.

- Prior to commencing any work, ensure that the actuator is safely disconnected from the power supply system.
- Secure against unauthorised restarting.

- 1 Open the cover (201) of the linear actuator.
⇒ 4.4 Assembling/disassembling the cover on page 15
- 2 **24 V:** Clip the PCB for the mA output signal to the safety catches inside the cover (201).
230 V: Push the PCB for the mA output signal onto the three spacers of the (27) push-fit PCB (107).
⇒ diagram 14 on page 22

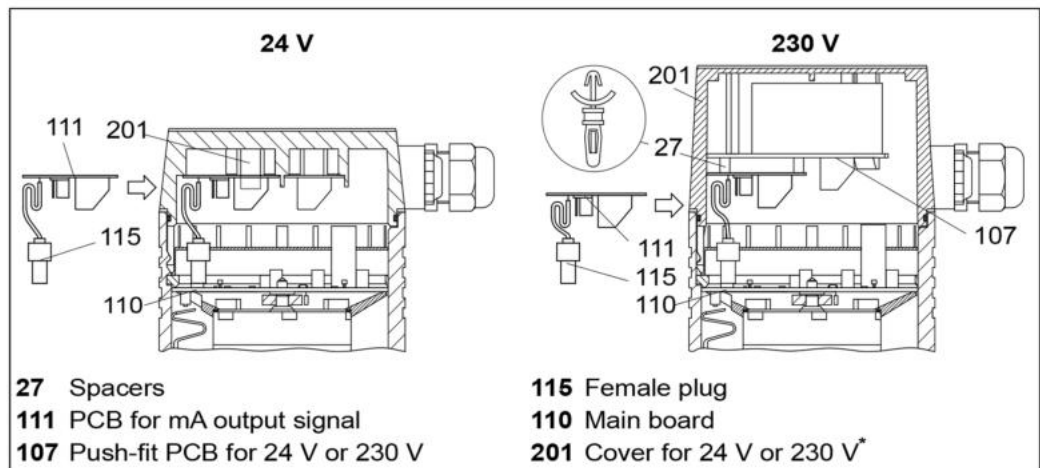

diagram 14 Fitting a PCB for the mA output signal

- 3 Push the female plug of the (115) PCB for the mA output signal onto the pin strip (123) of the main PCB (110). In the process pay attention to the notches on the socket board and female plug.
- 4 Attach the single cable from the PCB (111) for the mA output signal to terminal X of the push-fit PCB (107).
- 5 Use the jumper to select the signal range for the output signal:
 - Jumper right: 4 ... 20 mA
 - Jumper left: 0 ... 20 mA

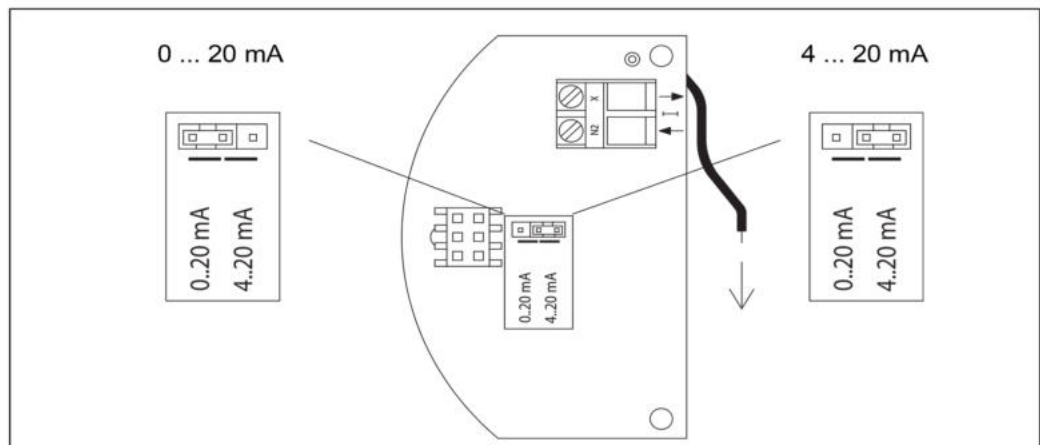

diagram 15 Setting the PCB for the mA output signal

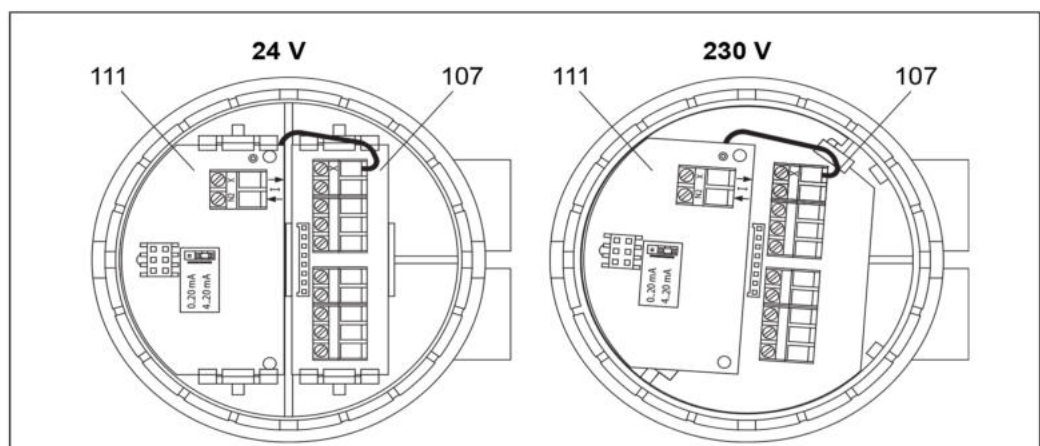

diagram 16 Connecting the PCB for the mA output signal to the push-fit PCB

5 Commissioning



Risk of injury from electric shock by live parts!

When the power supply is on there is a danger of electric shock due to live parts.

- Prior to commencing any work, ensure that the actuator is safely disconnected from the power supply system.
- Secure against unauthorised restarting.

Operating parameters are set at the encoding switches (**116**) and jumpers. The encoding switches and jumpers are situated underneath the PCB cover (**33**) in the actuator housing (**1**).

⇒ 4.4 Assembling/disassembling the cover on page 15

⇒ 4.5.2 Removing the PCB cover on page 19

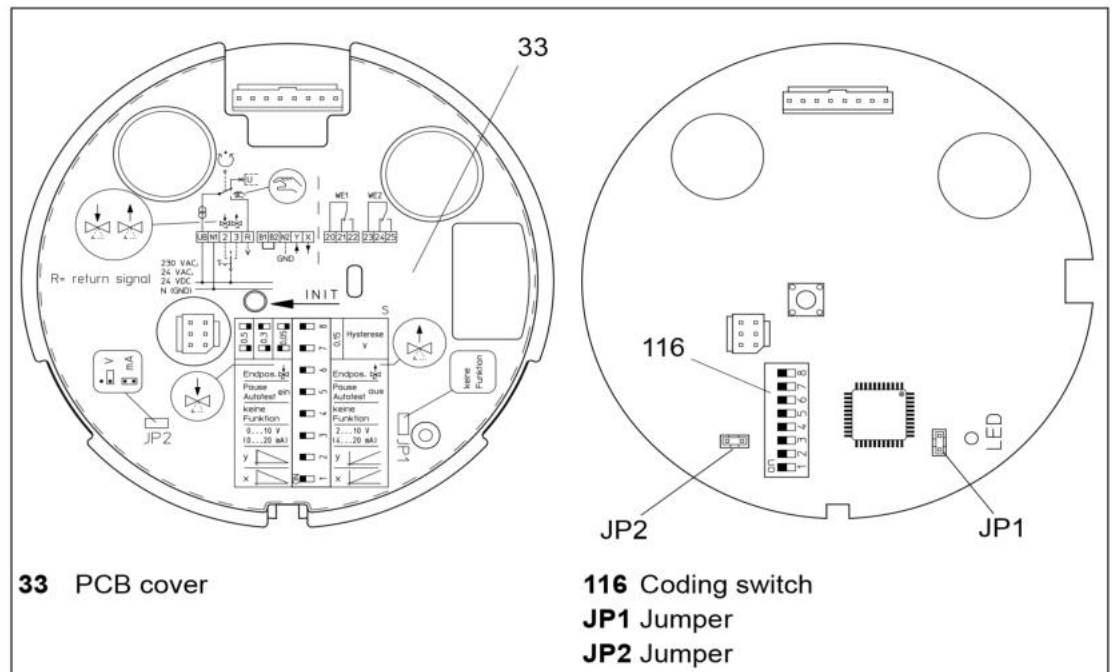

diagram 17 PCB cover, encoding switch and jumper

5.1 Operating parameters and encoding switch settings

Before starting to operate the linear actuator you will have to set the operating parameters with the help of the encoding switches and jumpers.

Switch / jumper	on	off
S1	X-characteristic line 	X-characteristic line 
S2	Y-characteristic line 	Y-characteristic line 
S3	Input signal (Y) 0 ... 10 V DC bzw. 0 ... 20 mA	Input signal (Y) 2 ... 10 V DC bzw. 4 ... 20 mA
S4	Actuating time 4s/mm	Actuating time 6 s/mm
S5	Auto test and auto pause on	Auto test and auto pause off
S6	Limit position actuator spindle extended	Limit position actuator spindle retracted
S7, S8	S7 and S8 are used to set the hysteresis (0.15...0.5V).	
JP1	Actuating force 1 kN	Actuating force 1.6 kN
JP2	Input signal (Y) in mA	Input signal (Y) in V

table 4 Encoding switch and jumper settings

5.2 Setting the input signal

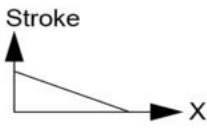
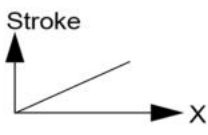
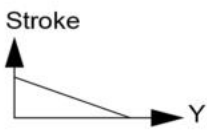
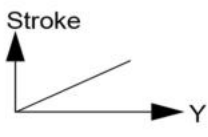
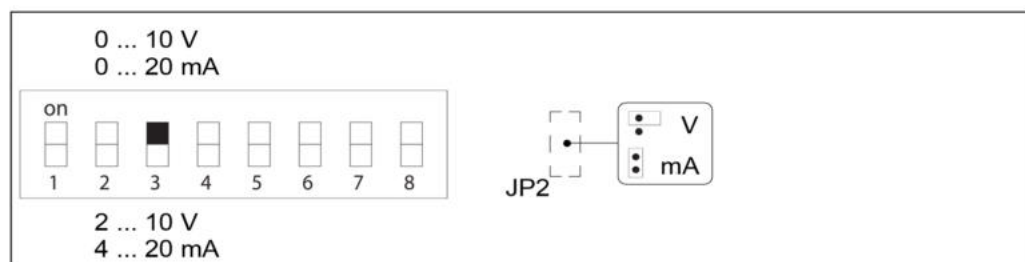

diagram 18 Setting the input signal

⇒ Additional information: *Input signal (Y)* on page 8

5.3 Setting the hysteresis

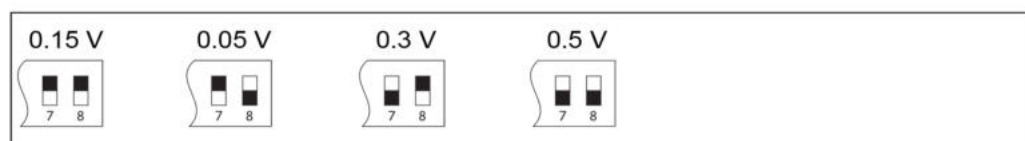

diagram 19 Set hysteresis

⇒ For further information see 2.4.5 *Hysteresis* on page 9

5.4 Setting the actuating direction

You can use the encoding switch (reverse operation) to reverse the actuating direction of the linear actuator.







Actuator setting	Normal operation	Reverse operation (X and Y reversed)
	<div style="display: flex; flex-direction: column; gap: 10px;"> <div>  <p>\square V JP2 Y = 10 V DC</p> </div> <div>  <p>\bullet mA JP2 Y = 20 mA</p> </div> </div>	<div style="display: flex; flex-direction: column; gap: 10px;"> <div>  <p>\square V JP2 Y = 0 V DC</p> </div> <div>  <p>\square V JP2 Y = 2 V DC</p> </div> <div>  <p>\bullet mA JP2 Y = 0 mA</p> </div> <div>  <p>\bullet mA Y = 4 mA</p> </div> </div>
	<div style="display: flex; flex-direction: column; gap: 10px;"> <div>  <p>\square V JP2 Y = 0 V DC</p> </div> <div>  <p>\square V JP2 Y = 2 V DC</p> </div> <div>  <p>\bullet mA JP2 Y = 0 mA</p> </div> <div>  <p>\bullet mA JP2 Y = 4 mA</p> </div> </div>	<div style="display: flex; flex-direction: column; gap: 10px;"> <div>  <p>\square V JP2 Y = 10 V DC</p> </div> <div>  <p>\bullet mA JP2 Y = 20 mA</p> </div> </div>
<p>Encoding switch S1: X (output signal), encoding switch S2: Y (input signal)</p>		

table 5 Setting the actuating direction

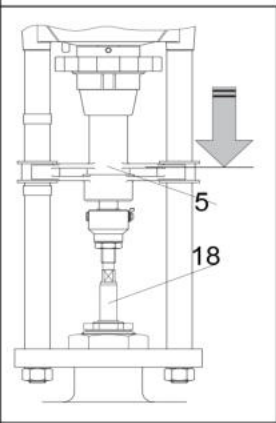
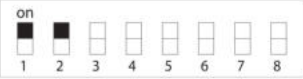
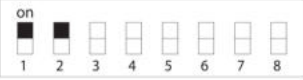
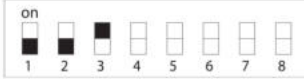
5.5 Setting auto test and auto pause

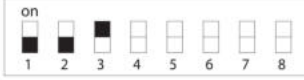
Auto test and auto pause are enabled when encoding switch S5 is set to ON. Approximately every 10 days the auto test triggers a start-up towards the limit position in rapid traverse mode. Rebalancing takes place at the same time. During auto pause a break of 3 seconds (measuring cycle 2 min) takes place after more than 20 direction varying traverse commands per minute. These two functions cannot be selected individually.

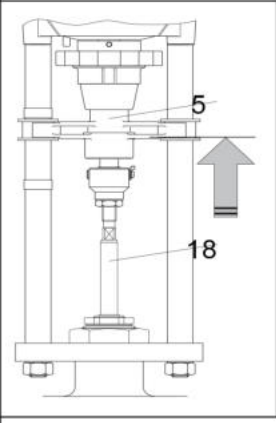
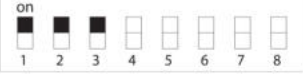
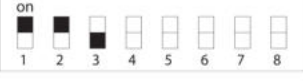
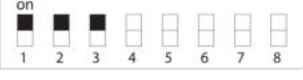
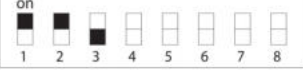
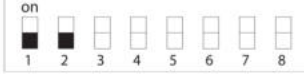
5.6 Setting the limit position

Use encoding switch S6 to select the limit position for the linear actuator:

- S6 ON: Limit position with extended rotary guard
- S6 OFF: Limit position with retracted rotary guard

The limit position is approached in the following situations:

- Due to wire break detection by the Y signal (2 ... 10 V DC or 4 ... 20 mA only),
- Due to a binary signal (When electric circuit between terminal B1 and B2 is interrupted),
- During auto test
- After a cut in supply voltage (manual adjustment)

5.7 Setting a potential-free path switch

Trim-pots P1/P2 is used to set the path switches independently. Try out the sequence of operations for each position switch once.

■ How to set a path switch

- 1 Ensure that the linear actuator has been commissioned and initialised.

⇒ 5.9 Commissioning on page 29

⇒ 5.8 Initialising the path measuring system on page 28

ATTENTION

Malfunction caused by imprecisely set path switches!

If you have set the actuator to manual mode (without supply voltage) it is only possible to set the path switch approximately (central setting is the equivalent of a switch point of c. 50% lift).^{JP2}

- To set the path switch accurately, set the actuator to automatic mode.

- 2 Move the actuator to the position where the switch event is to be triggered. Follow the sequence of operations below with the supply voltage turned on.



Risk of injury from electric shock by live parts!

When the supply voltage is turned on there is a risk of electric shock from live parts.

- Take care not to touch any live parts.
- Take care to apply the tool in a way that does not cause short-circuit.

- 3 Open the cover (201).

⇒ 4.4 Assembling/disassembling the cover on page 15

Inside the cover is the path switch PCB (111).

- 4 Use a screwdriver to adjust the trim-pot until the path switch switches. The related LED will either light up or switch off.

Potentiometer P1 (105 P1) is used to set path switch 1.

LED 1 shows the switching status.

Potentiometer P2 (105 P2) is used to set path switch 2.

LED 2 shows the switching status.

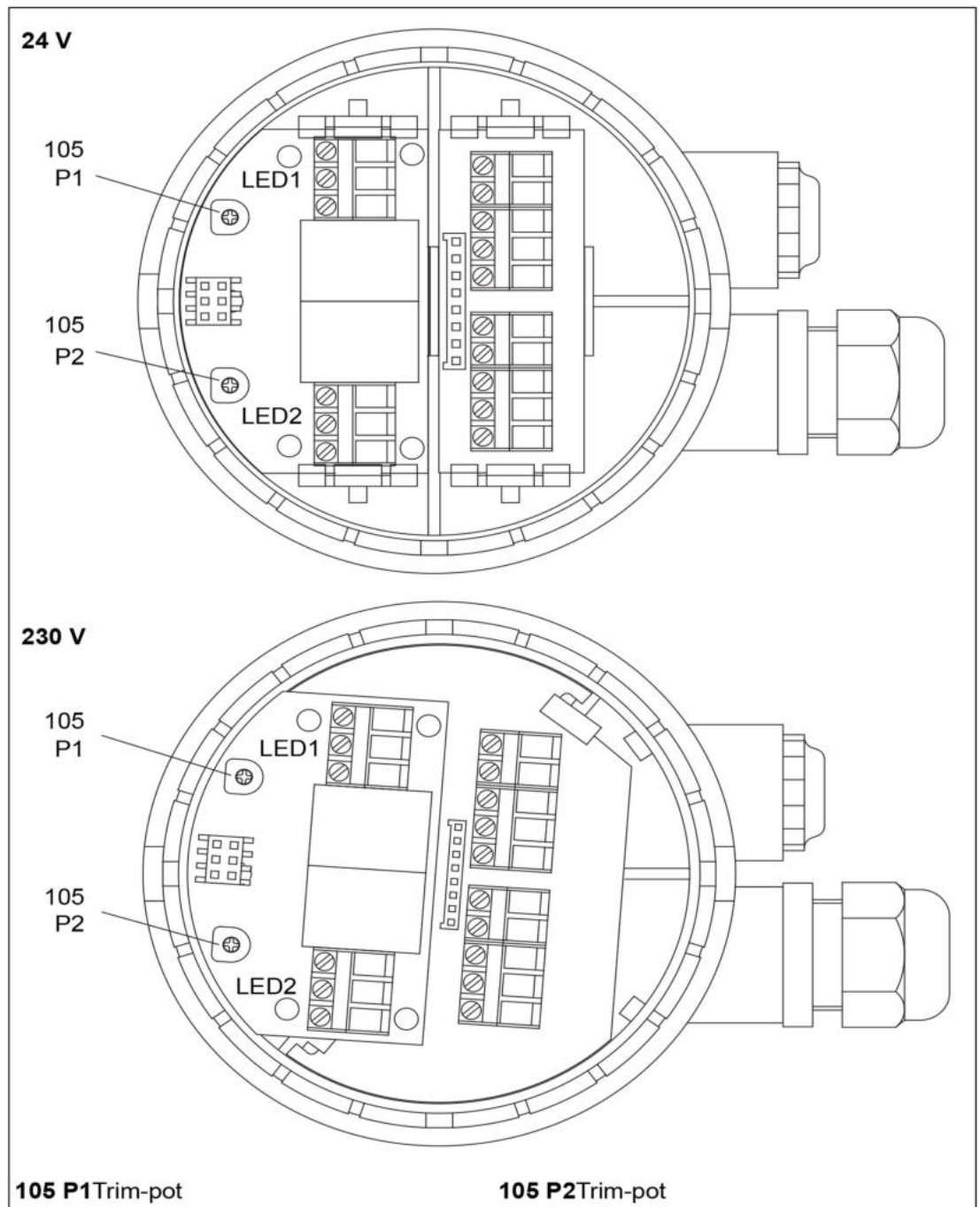

diagram 20 Position switch PCB in cover

- 5 Comply with the allowable contact load for the path switch:

Nominal load	8 A, 250 V AC 8 A, 30 V DC
Switch voltage	max. 400 V AC max. 125 V DC

table 6 Contact load of path switch

- 6 Disconnect the actuator from the supply and connect the path switch contacts.
- 7 Close the cover (**201**) of the linear actuator
- ⇒ How to attach the cover on page 15

5.8 Initialising the path measuring system

ATTENTION

Linear actuator starts automatically!

The linear actuator starts immediately after being connected to the supply voltage and automatically moves to a reference point of the path measuring system.

- Wait until this reference point has been reached and the linear actuator has stopped.

The path measuring system has to be initialised after the following:

- At initial commissioning
- After repairs to the valve or actuator
- After a replacement of valve or actuator

Initialisation may be triggered in two different ways.

■ How to initialise via the initialising button



Risk of injury from electric shock by live parts!

When the supply voltage is turned on there is a risk of electric shock from live parts.

- Take care not to touch any live parts.
- Take care to apply the tool in a way that does not cause short-circuit.

- 1 Open the cover (201).
⇒ 4.4 Assembling/disassembling the cover on page 15
- 2 Ensure that supply voltage is applied.
- 3 Press the initialising button (118) and keep it pressed for at least 1 second.

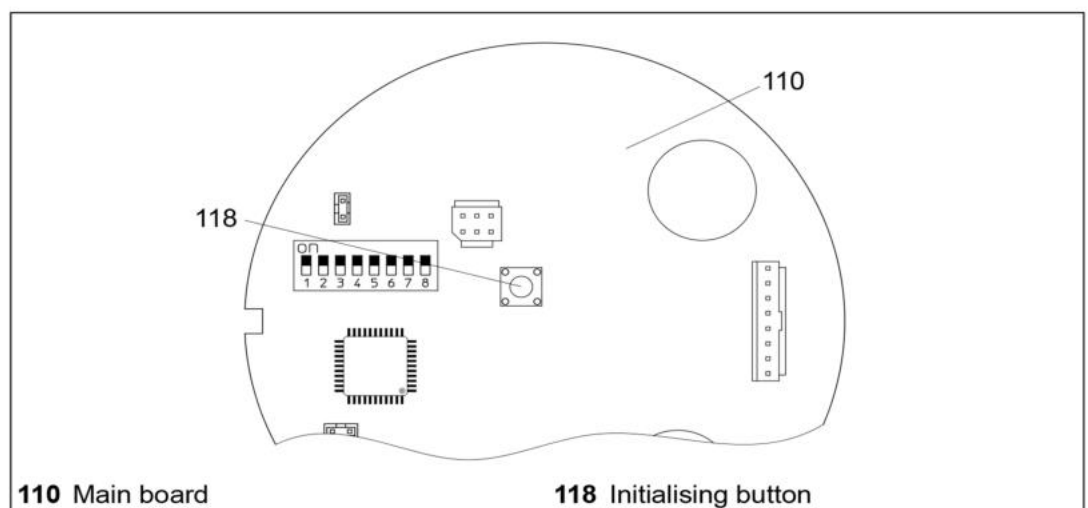

diagram 21 Initialising the path measuring system

■ How to initialise via the connecting terminals

- 1 Apply supply voltage simultaneously to terminals 2 and 3, making sure that supply voltage is applied for at least 1 second.
⇒ diagram 9 on page 17

5.9 Commissioning

- 1** Check whether all fitting and assembly work has been competently finished.
⇒ *4 Assembly* on page 12
- 2** Ensure that the electrical actuation of the linear actuator can take place safely without putting people or devices at risk.
- 3** Ensure that the linear actuator is attached correctly and that the cover of the linear actuator is closed.
⇒ *4.4 Assembling/disassembling the cover* on page 15
- 4** Ensure that the linear actuator is set to automatic mode.
⇒ *6.1 Changing between manual and automatic mode* on page 30
- 5** Ensure that the operating parameters are set correctly.
⇒ *5.1 Operating parameters and encoding switch settings* on page 24
- 6** Ensure that the path measuring system is initialised.
⇒ *5.8 Initialising the path measuring system* on page 28
- 7** Apply supply voltage. The linear actuator will now move to the reference point.
The linear actuator is ready for operation.

6 Operation

Prior to commissioning the linear actuator you will have to initialise it and select the operating mode.

⇒ 5 Commissioning on page 23

⇒ 5.8 Initialising the path measuring system on page 28

6.1 Changing between manual and automatic mode

It is possible to run the linear actuator in automatic mode or manual mode (manual adjustment).

- In automatic mode the rotary guard moves to the position set by the controller.
- In manual mode it is possible to set the spindle manually, e. g. for control purposes. Output signal (X) is not available in manual mode.

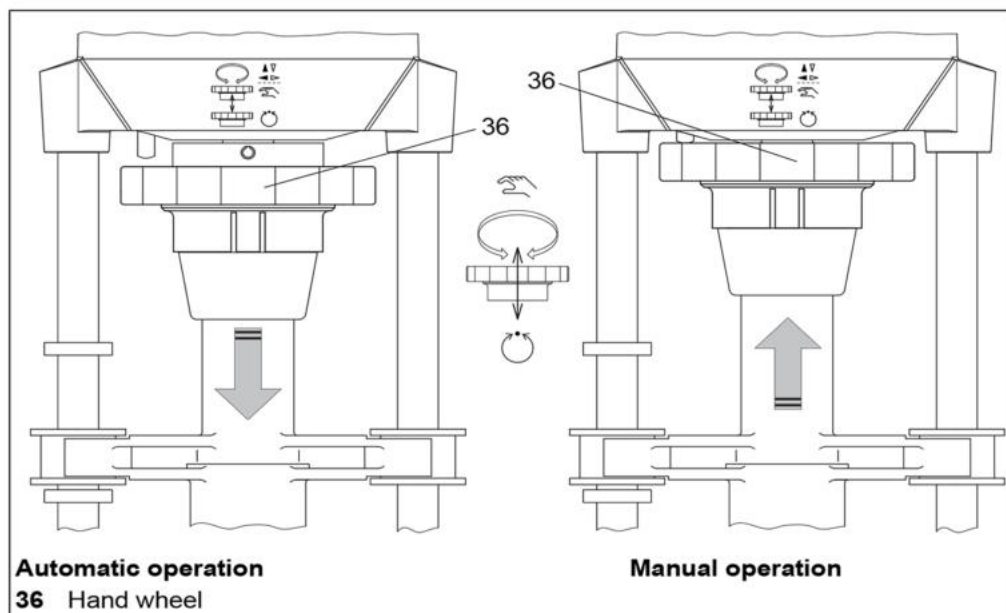

diagram 22 Selecting automatic mode

■ How to change-over in manual mode

- 1 Move the hand wheel (36) to manual mode position by turning until the hand wheel locks noticeably.

Risk of damage to valve and actuator during manual mode!

ATTENTION

The valve may get damaged if it is pushed too hard into its receptacle during manual mode.

- Do not try and keep turning the hand wheel when you realise that the required effort increases noticeably!
- Never use force !

- 2 Use the hand wheel to turn the rotary guard to the desired position. Turn the hand wheel until the preset potentiometer increases. Do not use force!

■ How to change-over in automatic mode

- 1 Push the hand wheel (36) to automatic mode position.
- 2 The linear actuator first moves to the position specified by encoding switch S6 and then to the position preset by the controller.

6.2 LED display

The LED on the main PCB in the actuator indicates the operating status or errors.

⇒ 10.2 Check list for breakdown on page 33





LED	Operating status / error
 Duration	Normal operation, ready for operation The LED is permanently lit, actuator waiting for traverse command.
 0,5s 0,5s 0,5s 0,5s	Standard Operation Actuator carries out traverse command.
 0,2s 1,5s 0,2s 1,5s Short – long rhythm	Wire break detection Input signal has dropped below 1 V or below 2 mA in operating modes 2 ... 10 V DC or 4 ... 20 . ⇒ 2.4.3 Wire break detection on page 8
 2,5s 2,5s 2,5s 2,5s Long – long rhythm	Blockage detection (continuous mode only) The linear actuator is mechanically blocked. ⇒ 2.4.2 Blockage detection on page 8
 1,5s 0,2s 1,5s 0,2s Long – long rhythm	Continuous signal on terminal 2 and 3 A simultaneous control signal at terminal 2 and 3 will result in an initialising cycle (max. 4 attempts). The linear actuator will automatically switch off after 4 unsuccessful attempts.

table 7 Display LED

7 Maintenance, care and repairs

The linear actuator requires little maintenance. You do not have to carry out continuous or periodical maintenance.

8 Spare parts

When ordering accessories and spare parts please quote the specifications engraved on the type plate of your linear actuator. The specifications on the type plate are standard for the technical date of linear actuators as well as the requirements for the public power supply.

ATTENTION

Damage to device caused by faulty spare parts!

Spare parts must match the technical data specified by the manufacturer.

- Use genuine spare parts at all times.

⇒ 2.1 Component parts on page 6

⇒ 2.2 Accessories on page 7

9 Decommissioning and disposal

Dispose of the linear actuator according to national regulations and laws.

10 Removal of faults

After remedying faults you will have to re-initialise the path measuring system.

⇒ 5.8 Initialising the path measuring system on page 28

10.1 How to remedy faults

If the linear actuator does not work properly follow the sequence of operations described below in order to remedy the fault:

- 1 Check whether the linear actuator was correctly assembled.
- 2 Check the settings for the linear actuator against the specifications on the type plate.
- 3 Remedy the fault by following the check list.
⇒ 10.2 Check list for breakdown on page 33
- 4 If you are unable to remedy the fault contact the manufacturer.
- 5 For all queries at the manufacturer's and when sending back the device please quote the following :
 - SN (serial number = order number)
 - Type denomination
 - Supply voltage and frequency
 - Accessory equipment
 - Error report
- 6 If you are unable to remedy the fault despite inquiry you can send the device to the manufacturer.

10.2 Check list for breakdown

Fault	Cause/reason	Remedy
1. Linear actuator is not working.	Hand wheel (36) is in position manual mode	<input type="checkbox"/> Switch hand wheel to position automatic mode.
	Power cut	<input type="checkbox"/> Determine cause and remedy.
	Fuse defective (in control cabinet)	<input type="checkbox"/> Determine cause and remedy, replace fuse.
	Linear actuator incorrectly connected	<input type="checkbox"/> Set connection correctly according to wiring diagram (on cover).
	Short circuit due to humidity	<input type="checkbox"/> Determine cause, dry the linear actuator; replace cover seal or screw joints and/or attach protective cover, as required.
	Short circuit due to incorrect connection	<input type="checkbox"/> Correct setting for connection
2. Linear actuator running unsteadily, i. e. veering between clockwise and anti-clockwise rotation.	Motor has winding damage (burnt-out) <ul style="list-style-type: none"> • e.g. voltage too high • Electronic system defective 	<input type="checkbox"/> Determine cause, measure current data, Compare to type plate and table, Disassemble linear actuator and send it in for repairs.
	Drop of voltage due to excessively long connecting cables and / or insufficient diameter.	<input type="checkbox"/> Measure the current data; if required, recalculate and replace connecting cables!
3. Linear actuator pauses intermittently or initialises frequently	Public power supply fluctuations greater than admissible tolerance ⇒ 2.5 <i>Technical data</i> on page 10	<input type="checkbox"/> Improve public power supply conditions
	Slack contact in feeder line	<input type="checkbox"/> Check and tighten connections (terminal strips)
4. Linear actuator does not move to limit position. Valve does not open/close.	Valve is stuck	<input type="checkbox"/> Provide smooth-running valve
	Excessive system pressure	<input type="checkbox"/> Adjust system pressure
5. Linear actuator does not move at all or not correctly to the position preset by input signal Y	Input signal Y is faulty: <ul style="list-style-type: none"> • Interfering signals • Signal variations 	<input type="checkbox"/> Check input signal Y on linear actuator, remove cause of fault
	Main PCB defective	<input type="checkbox"/> Replace main PCB or disassemble linear actuator and send it in for repair
6. LED flashes in long / long rhythm	Blockage detection was triggered	<input type="checkbox"/> Press INIT and observe actuator during initialisation. <input type="checkbox"/> Check valve for smooth-running along entire traverse range
7. LED flashes in short / long rhythm	Wire break was detected	<input type="checkbox"/> Measure desired value voltage and current on linear actuator
8. LED flashes in long / short rhythm	Relay contact adhesive	<input type="checkbox"/> Check controller

table 8 Check list breakdown