

Operating Manual

Linear actuators with spring reset device

MLH103ZC • MLH103ZA

General information

Amendment	Version	Date	Modifications
	1.0	March 2008	Initial preparation
	1.1	August 2009	Technical revision
	1.2	March 2011	Revision

Copyright The copyright for this operating manual as well as all rights in case of patent awarding or registration of registered design remains with the manufacturer!

Subject to alteration The regulations, directives, standards etc. are compliant with the current state of information at the time of development and are not subject to modification service. They must be applied by the operator at his own responsibility in their latest valid version.

Concerning all data, information, and illustrations in this manual we reserve the right of technical modifications and improvements. No claims can be considered for alteration or rework of already delivered lift drives.

Table of contents

1 Safety	4	5 Commissioning	22
1.1 Proper use	4	5.1 Operating parameters and encoding switch settings.....	23
1.2 Information for the operator	4	5.2 Setting the input signal.....	23
1.3 Personnel.....	5	5.3 Setting the actuating time.....	23
1.4 Prior to starting work.....	5	5.4 Setting the hysteresis.....	24
1.5 During operation	5	5.5 Setting the actuating direction.....	24
1.6 Working environment.....	5	5.6 Setting auto test and auto pause	24
2 Product Specification	6	5.7 Setting the limit position	25
2.1 Component parts	6	5.8 Setting a potential-free path switch.....	25
2.2 Accessories	7	5.9 Initialising the path measuring system	27
2.3 Operating modes	7	5.10 Commissioning.....	28
2.3.1 Continuous mode	7	6 Operation	29
2.3.2 Three-point mode	8	6.1 Changing between manual and automatic mode...29	
2.4 Functions	8	6.2 LED display	30
2.4.1 Binary signal / frost protection function.....	8	7 Maintenance, care and repairs	30
2.4.2 Blockage detection	8	8 Spare parts	30
2.4.3 Wire break detection.....	8	9 Decommissioning and disposal	31
2.4.4 Actuating time.....	9	10 Removal of faults	31
2.4.5 Hysteresis.....	9	10.1 How to remedy faults	31
2.4.6 Manual mode and response signal.....	9	10.2 Check list for breakdown.....	32
2.4.7 Auto test	9		
2.4.8 Auto pause	9		
2.4.9 Potential-free limit switch (accessory)	9		
2.5 Technical data	10		
2.6 Type plate	11		
3 Transportation & Storage	11		
4 Assembly	12		
4.1 Checking the scope of delivery	12		
4.2 Preparing assembly	12		
4.3 Mounting the linear actuator on the valve.....	13		
4.4 Assembling/disassembling the cover.....	15		
4.5 Electrical connection.....	16		
4.5.1 Controller independent circuit.....	18		
4.6 Fitting accessories	19		
4.6.1 Fitting a PCB for a path switch	19		
4.6.2 Fitting the PCB for the mA output signal	20		

1 Safety

Read these Operating Instructions carefully particularly the following safety instructions prior to installation and operation.



DANGER

Directly threatening hazard leading to death or serious physical injuries.



WARNING

Potentially hazardous situation which may lead to death or serious physical injuries.



CAUTION

Potentially hazardous situation which could lead to minor physical injuries. Indicates a hazard which may cause material damage.



ATTENTION

Potentially hazardous situation where the product or an object in its environment may get damaged.

Hint: Utilisation instructions and other useful information.

1.1 Proper use

Linear actuator MLH103ZC, MLH103ZA are controlled by three-point control or constant control. Linear actuators in the series described in these Operating Instructions are used for valve stroke adjustment.

Concurrence of the above type designation with the linear actuator rating plate must be checked prior to starting any operations in order to guarantee utilisation in accordance with specification. The data on the rating plate is decisive for linear actuator technical data and mains power supply requirements.

Any utilisation for tasks other than the aforementioned usage in accordance with specification and operating with mains power supply ratios other than those permitted is not deemed to be utilisation in accordance with specification. The operator bears sole liability for the risk to persons and machine and other assets in the event of utilisation not in accordance with specification.

The intended use also includes the compliance with accident preventions, DIN VDE regulations and safe working practices for all measures described in these operating instructions in due consideration of prevailing rules.

1.2 Information for the operator

Always keep the Operating Instructions available at the linear actuator deployment site.

Observe the current health and safety, accident prevention and DIN VDE standards for installation, operation and maintenance.

Take into consideration any additional regional, local or in-house safety regulations.

Ensure that every person entrusted with one of the tasks specified in these Operating Instructions has read and understood these instructions.

1.3 Personnel

Only qualified personnel may work on these linear actuators or in their vicinity. Qualified persons are those persons entrusted with installation, assembly, commissioning and operation or maintenance of the linear actuators and possessing the appropriate qualifications for their activity. The necessary and prescribed qualifications include:

- Training / instruction or authorization to turn on /off circuits and appliances / systems according to EN 60204 (DIN VDE 0100 / 0113) and the standards of safety technology.
- Training or instruction according to the standards of the safety technology concerning care and use of adequate safety and work protection equipment.
- First Aid training.

Work in a safe manner and refrain from any working practice which endangers the safety of persons or damages the linear actuator or other assets in any way whatsoever.

1.4 Prior to starting work

Prior to starting any work, check that the type designations specified here concur with the data on the linear actuator rating plate.

Linear actuator MLH103ZC, MLH103ZA.

1.5 During operation

Safe operation is only possible if transportation, storage, installation, operation and maintenance are carried out safely and materially and professionally correctly.

Transportation, installation and assembly

Observe the general set-up and safety regulations for heating, ventilation, air-conditioning and pipework design. Use tools correctly. Wear the necessary personal and other safety equipment.

Repairs and maintenance

Ensure that qualified personnel switch off the linear actuator prior to maintenance or repair work in accordance with DIN VDE.

1.6 Working environment

Read the data concerning the working environment in the Technical Data.

2 Product Specification

The linear actuator is used to actuate and adjust lift valves. The lifting movement is generated by means of a spindle actuator coupled to a valve spindle comprising a pivoted spindle and a spindle nut secured against skewing. The actuation of the ball bearing mounted spindle is achieved by means of a stepper motor with interconnected two-step planetary gear. The stepper motor receives the rotary field required for operation from a micro controller based electric control.

The linear actuator comprises a spring reset device with an electro-hydraulically blockable spring. On commissioning the spring is tensed inside the hydraulic unit by the spindle actuator and blocked electro-hydraulically when reaching spring limit position. During a cut of supply voltage this spring will be unlocked and the clutch piece will move hydraulically dampened to the lower limit position – actuator spindle.

2.1 Component parts

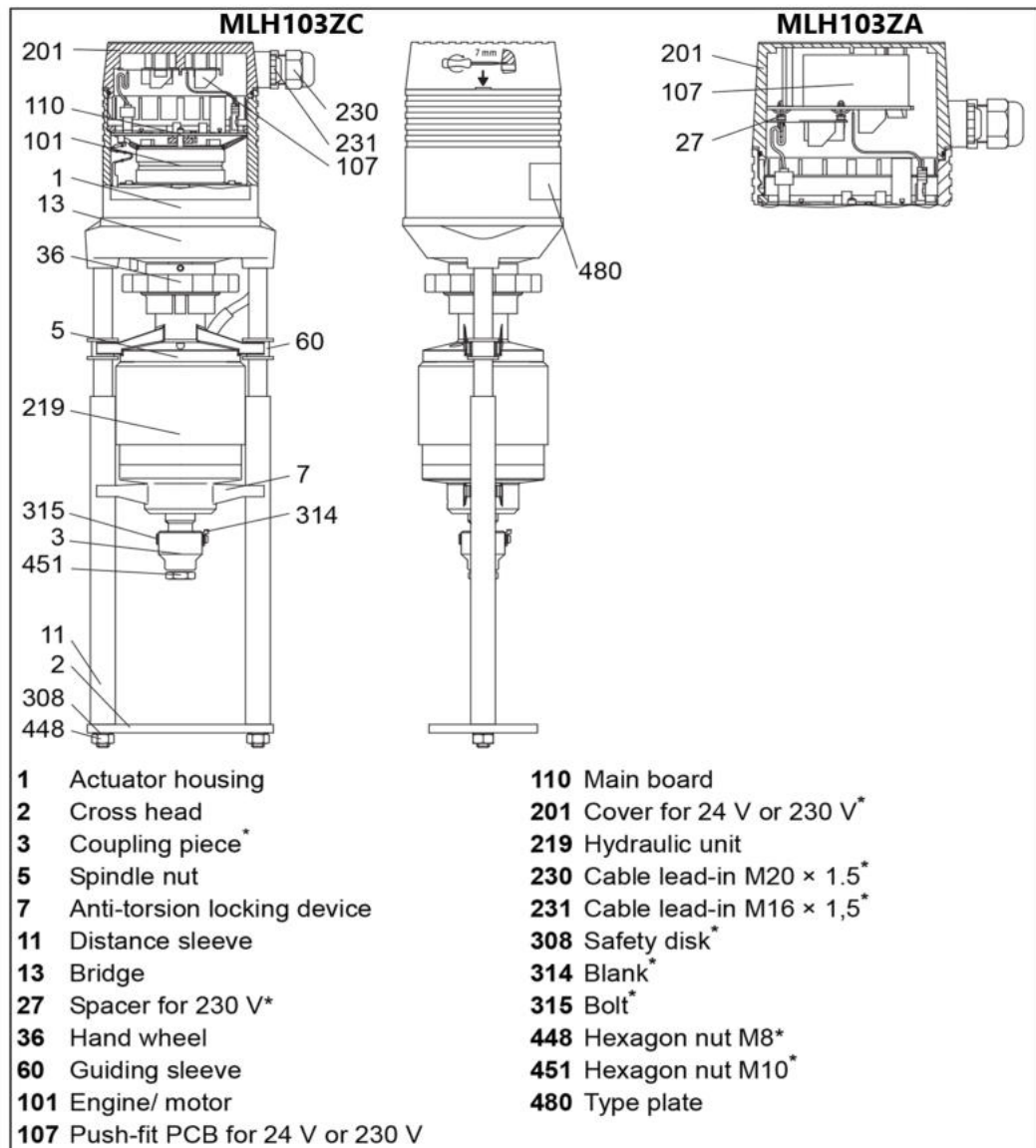

diagram 1 Component part denominations

* This component part is available as a spare part!

2.2 Accessories

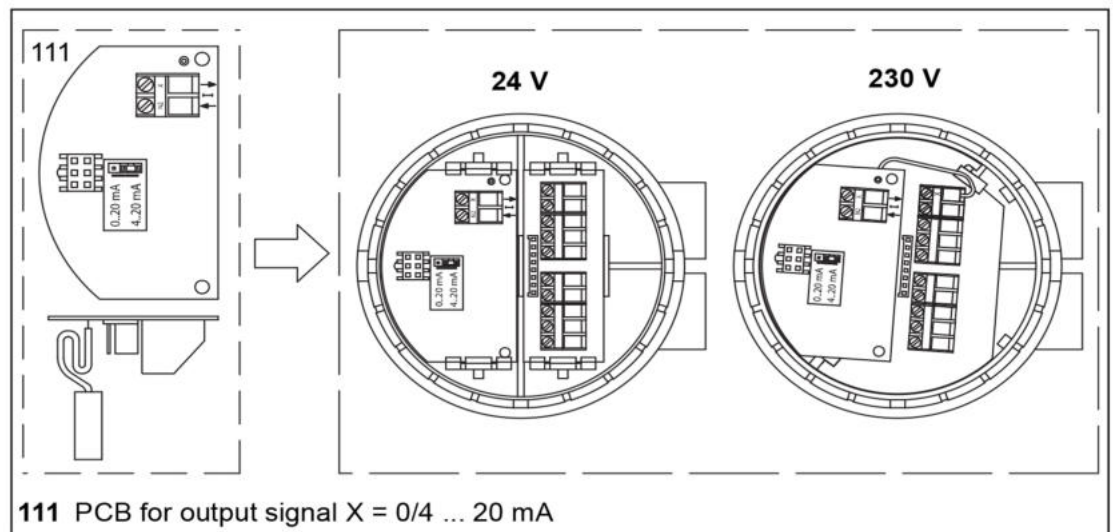

diagram 2 PCB for mA output signal in cover

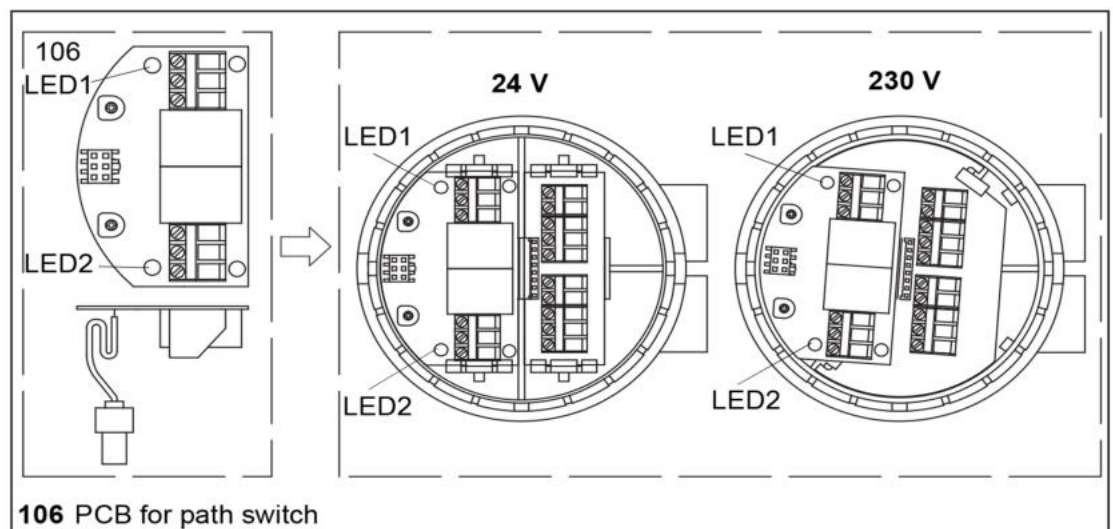

diagram 3 Position switch PCB in cover

Hint: Optional operation with mA output signal or path switch possible

2.3 Operating modes

The linear actuator can be operated manually or automatically.

- In manual mode stroke is adjusted via the hand wheel.
- In automatic mode stroke is controlled electrically.

2.3.1 Continuous mode

In continuous mode the system control presets the position of the linear actuator whilst inside the linear actuator the input signal (Y) of the system control is continuously compared with the output signal (X) of the linear actuator. In doing so the output signal depends on the position of the linear actuator (travel).

The linear actuator keeps moving until the input signal and the output signal match.

Input signal (Y) The input signal (Y) of the system control specifies the desired position for the linear actuator. It is applied in the form of an analogue signal to terminal Y.

Possible input signals:

- 0 ... 10 V DC / 2 ... 10 V DC
- 0 ... 20 mA / 4 ... 20 mA

Output signal (X) The output signal (X) determines the actual position of the linear actuator. It is applied to terminal X in the form of an analogue signal.

0% to 100% valve lift is put out as:

- 0 ... 10 V DC
- 0 ... 20 mA or 4 ... 20 mA (accessory PCB for output signal **(111)**)

2.3.2 Three-point mode

The direction of rotation is set via the control voltage at terminal 2 and terminal 3 on the main PCB:

- When the control voltage is applied to terminal 2, the spindle nut will be extended.
- When the control voltage is applied to terminal 3, the spindle nut will be retracted.

2.4 Functions

2.4.1 Binary signal / frost protection function

The terminals B1 and B2 on the main PCB are bridged during normal operation. If the electric circuit between B1 and B2 is interrupted, the linear actuator will store the current position and afterwards move automatically to its limit position.

All other control signals will be ignored during this process.

The linear actuator will remain in limit position until the electric circuit between B1 and B2 has closed.

- In three-point mode the linear actuator will automatically return to the stored position.
- In continuous mode the desired value of the input signal will be restarted.

2.4.2 Blockage detection

If the linear actuator is blocked manually, the linear actuator will briefly move back and then retry to reach the required position. If this is still unsuccessful after a total of 7 attempts the linear actuator will be turned off in order to prevent damage to the linear actuator and the control element.

Blockage detection is indicated by LED

⇒ 6.2 LED display on page 30

2.4.3 Wire break detection

Wire break detection is only available for continuous mode with an input signal 2 ... 10 V DC and 4 ... 20 mA.

When the input signal drops below 1 V or 2 mA in continuous mode the linear actuator will move to the limit position set by encoding switch S6.

Wire break detection is indicated by the LED.

⇒ 6.2 LED display on page 30

2.4.4 Actuating time

The time required for the spindle nut to travel a defined distance is called actuating time. Actuating time is specified in s/mm. Encoding switch S4 is used to set the actuating time.

⇒ 5.3 *Setting the actuating time* on page 23

2.4.5 Hysteresis

Hysteresis equals the difference of the input signal (Y) that is required after a reversal of signal direction in order to move the spindle nut.

It serves to prevent permanent oscillation of the actuator motor around a certain hoisting position during minor input signal alterations.

⇒ 5.4 *Setting the hysteresis* on page 24

2.4.6 Manual mode and response signal

During manual mode you will only be able to change the lift when voltage is applied and the spring of the response unit is in a tensed state.

- Motor and control electronics are turned off in manual mode to make hoisting movements of the control impossible.
- The moment you set the linear actuator to manual mode the control switches a signal to terminal R, provided supply voltage is applied.

⇒ 6.1 *Changing between manual and automatic mode* on page 29

2.4.7 Auto test

If a valve is not actuated for a long time the valve cone may get stuck. The auto test function acts as a preventative measure. When you turn on the auto test function for the linear actuator, the linear actuator will automatically move after c. 10 days without actuation to the limit position set by encoding switch S6 and return to initial position .

⇒ 5.6 *Setting auto test and auto pause* on page 24

2.4.8 Auto pause

This function is used by the actuator to count the traverse commands per minute that involve a change of direction. If there are more than 20 direction varying traverse commands per minute this will result in a compulsory pause of 3 s.

⇒ 5.6 *Setting auto test and auto pause* on page 24

2.4.9 Potential-free limit switch (accessory)

The optional path switch PCB allows you **(106)** to set two actuating positions within which a potential-free contact is opened or closed.

⇒ 5.8 *Setting a potential-free path switch* on page 25

2.5 Technical data

Type	MLH103ZC	MLH103ZA
Supply voltage	24 V AC \pm 10%	115 V AC \pm 10% 230 V AC + 6% -10%
Power consumption	max. 25 VA	max. 20 VA
Weight	4.8 kg	5.1 kg
Dimensions	See technical data sheets	
Stroke	max. 20 mm	max. 20 mm
Frequency	50/60 Hz \pm 5%	50/60 Hz \pm 5%
Ambient temperature	0 to +60°C	0 to +60°C
Enclosure protection	IP 54	IP 54
	Suitable for use in the usual environment	
Operating mode	S3-50% ED	S3-50% ED
Actuating time	4 or 6 s/mm	4 or 6 s/mm
Emergency actuating time	0.1 s/mm	0.1 s/mm
Actuating force	1.0 kN	1.0 kN
Recommended external protection	T1,6 A	T200 mA (115 V) T125 mA (230 V)
Temperatur limits transformer cover		T60 (EN60730 6.7; 14.5; 14.7; 17.3)
Surge voltage raiting	Overvoltage category 2 (EN60730 20.1.12; 20.1)	
Ball pressure testing temperature	Ball pressure test 1 test temperature 140°C (EN60730 21.2.5)	
Function	Control function according to EN 60730 = 1 Spring return function according to EN 60730 = 2	

table 1 Technical data

Input signal Y/ Resistance of load	<ul style="list-style-type: none"> • 0 ... 10 V DC / 77 kΩ • 2 ... 10 V DC / 77 kΩ • 0 ... 20 mA / 510 Ω • 4 ... 20 mA / 510 Ω
Output signal X/ Load rating	<ul style="list-style-type: none"> • 0 ... 10 V DC / resistance of load \geq 1200 Ω, $I_{max.}$ 8 mA • 0 ... 20 mA / resistance of load \leq 500 Ω - with accessory PCB for output signal (111) • 4 ... 20 mA / resistance of load \leq 500 Ω - with accessory PCB for output signal (111)
Response signal R/ load rating	• 24 V DC / minimum impedance \geq 480 Ω / $I_{max.}$ 35 mA
Cable impedance between B1 and B2	• max. 10 Ω

table 2 Technical data signals

2.6 Type plate

The type plate is attached to the housing of the linear actuator.

It bears the type denomination, serial number (s/no) and date of manufacture (last four digits).

⇒ 2.1 Component parts on page 6



		 	
MLH103ZA			
F.-Nr.: 10200498C/01/0210		Zertifikats-Nr.: 01 202 931-B-09-0002-01	
AC 50 Hz 230 V	25 VA	0,1 kN	Hub 20 mm T60
Y= 3-Punkt	IP 54	4 s/mm	Stellzeit
X= 0...10 V DC	S3-50% ED	0,1 s/mm	Rückstellzeit

diagram 4 Example of type plate

2.7 Prototype test

EC-prototype test in accordance with the guideline 97/23/EC which is only valid when the actuator is used with HORA valves BR 225, BR 240S or BR240E. Prototype test in accordance with regulations of EN14597; paragraph DX17 and EN60730.

- Further data must be taken from the operating manual BR225 / 240S / 240E with MLH103Z, the prototype test certificate or the Conformity Declaration (www.hora.de).

3 Transportation & Storage



Non-compliance with safety regulations may result in injury!

- Wear the required personal and other safety equipment.
- Avoid impacts, blows, vibrations etc. to the linear actuator.
- Store the linear actuator (and, where appropriate, the entire controlling device) in a dry place.
- Keep to the specified transport and storage temperatures between -20 to +65° C.

4 Assembly

Prior to assembling the linear actuator:

⇒ 4.1 *Checking the scope of delivery* on page 12

⇒ 4.2 *Preparing assembly* on page 12

The following sequence of operations is part of the linear actuator assembly:

⇒ 4.3 *Mounting the linear actuator on the valve* on page 13

⇒ 4.4 *Assembling/disassembling the cover* on page 15

⇒ 4.5 *Electrical connection* on page 16

4.1 Checking the scope of delivery

- 1 Check the packaging for damage.
- 2 Dispose of packaging in an environmentally friendly manner.
- 3 Check the delivered items against the delivery note in order to see whether the delivery is complete.
- 4 Report any missing or damaged products to the manufacturer.

4.2 Preparing assembly



A non-attached valve causes damage!

If you operate the linear actuator without valve, the spindle nut may fall off due to the missing stop.

- Always operate the linear actuator with a valve attached.

- 1 Allow for about 140 mm space above the cover at the site of installation.
- 2 Check the working environment before assembling and commissioning the linear actuator:
- 3 Ensure that the valve is correctly fitted. For details please see assembly instructions for valve.
- 4 Determine the assembly position of the linear actuator. Do not arrange linear actuators in a hanging position.

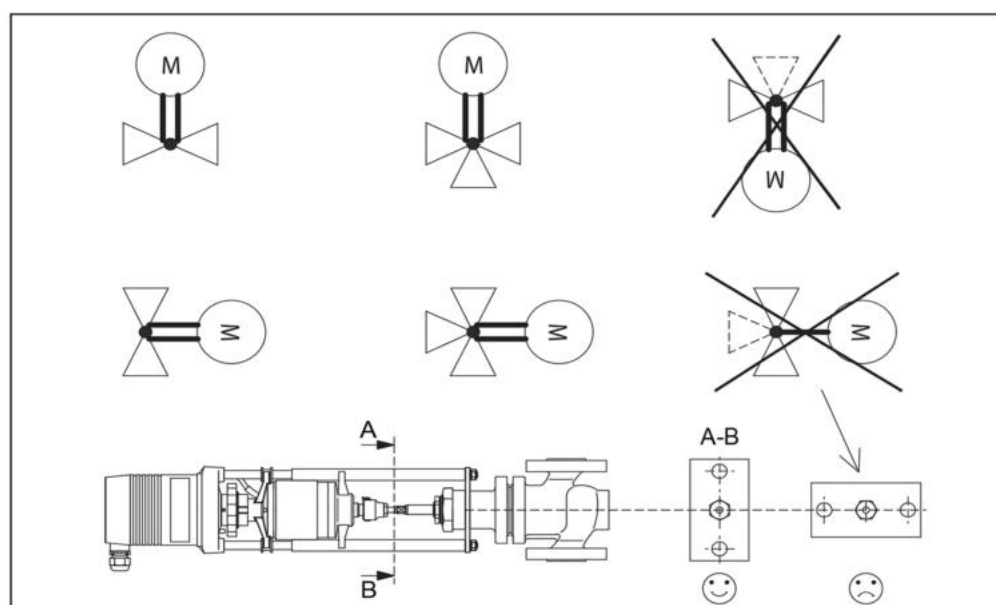

diagram 5 Assembly positions for linear actuator and valve

4.3 Mounting the linear actuator on the valve

If the linear actuator and the valve are supplied separately you will have to mount the linear actuator on the valve.

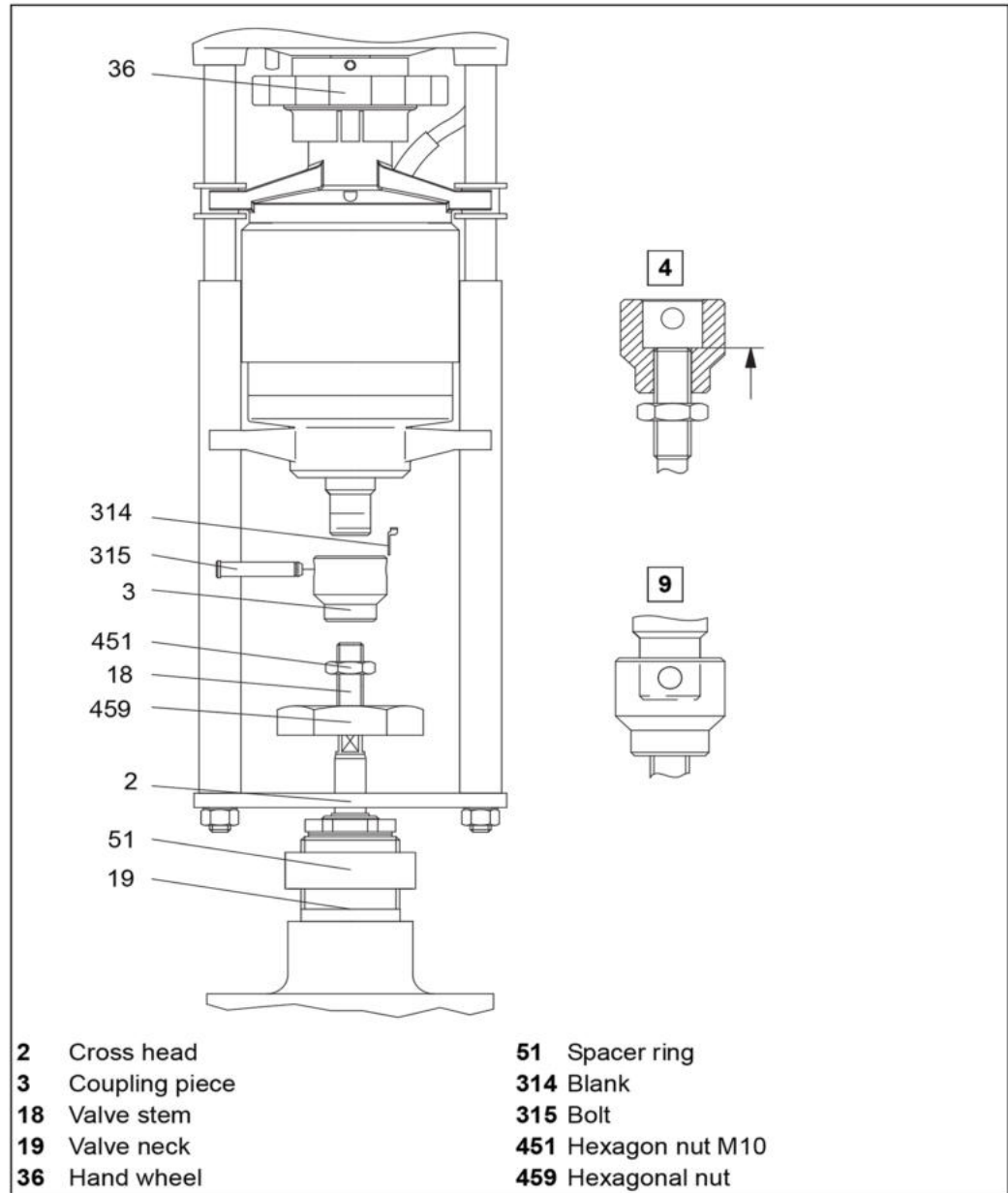

diagram 6 Mounting the linear actuator on the valve

■ **How to assemble linear actuator type MLH103Z :**

- 1 Pull off the blank (**314**).
⇒ *diagram 6 Mounting the linear actuator on the valve on page 13*
- 2 Pull out the bolt (**315**) from the clutch piece (**3**) or drive it out.
- 3 Screw the hexagon locknut M10 (**451**) spanner width 17 onto the valve stem (**18**).
- 4 Screw the clutch piece (**3**) onto the valve spindle (**18**). The area of the valve stem (**18**) must be flush with the area of the clutch piece (**3**).
⇒ *diagram 6 Mounting the linear actuator on the valve on page 13 (Detail 4).*

- 5 Put the actuator into upper limit position by means of the hand wheel **(36)** and check whether it has reached the upper limit position.
 - 6 Fit the spacer **(51)** on the valve neck **(19)**.
 - 7 Fit the actuator and crossbeam **(2)** and hexagon nut **(459)** on the valve neck **(19)**. Make sure that the valve spindle is in bottom position.
 - 8 Fix the crossbeam **(2)** using the hexagon nut **(459)** hand tight.
 - 9 Turn the clutch piece **(3)** until both borings are congruent.
⇒ *diagram 6 Mounting the linear actuator on the valve on page 13 (Detail 9).*
 - 10 Turn the clutch piece anti-clockwise by **(3)** one rotation (360°).
 - 11 Loosen the hexagon nut **(459)** spanner width 50 and lift the actuator by c. 1.5 mm.
 - 12 Insert the bolt **(315)** in the clutch piece **(3)** and secure it with a blank **(314)**.
 - 13 Tighten the hexagon nut **(459)** spanner width 50.
 - 14 Fix the valve stem **(18)** by hexagon locknut M10 **(451)** spanner width 17 in order to secure it against skewing.
- **How to disassemble the linear actuator**
- 1 Move the linear actuator to the upper limit position (MAN / AUTO).
 - 2 Turn the actuator by two rotations of the hand wheel away from the limit position.
 - 3 Loosen the hexagon nut **(459)** spanner width 50.
 - 4 Pull off the blank **(314)**.
 - 5 Pull out the bolt **(315)** from the clutch piece **(3)** or drive it out.
 - 6 Remove the actuator.

4.4 Assembling/disassembling the cover

The cover contains the terminals for electric connection.



Risk of injury from electric shock by live parts!

When the power supply is on there is a danger of electric shock due to live parts.

- Prior to commencing any work, ensure that the actuator is safely disconnected from the power supply system.
- Secure against unauthorised restarting.
- Remove the cover only momentarily.

■ **How to remove the cover**

- 1 Insert a screwdriver in the notch of the cover and lift the cover **(201)**.

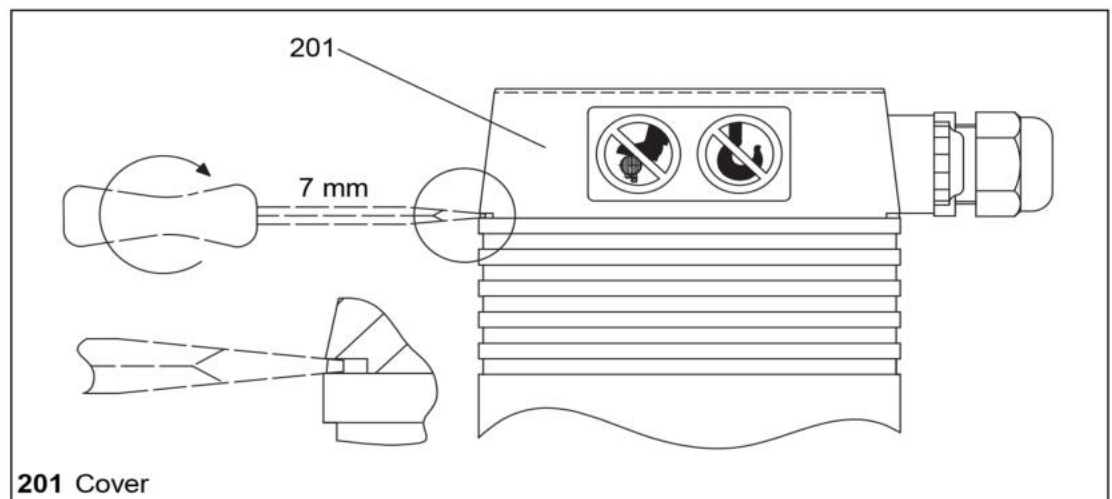

201 Cover

diagram 7 Removing the cover



Damaged cables result in damage to devices!

When lifting the cover you may tear off or damage the cabling inside the cover.

- Carefully remove the cover.

- 2 Remove the cover **(201)** carefully.
- 3 Disconnect the plug-in connection between the main PCB and the **(110)** cover **(201)**.

■ **How to attach the cover**

- 1 Plug the previously pulled off cables back into the main PCB **(110)**.
Pay attention to the notches on plug and socket.

Hint: You can mount the cover **(201)** in four, different, positions each of which is transposed by 90°. This allows the best possible laying of the connecting cable for different installations of the linear actuator.

- 2 Place the cover **(201)** on top and push it down to make it fit by applying moderate force.
- 3 Check the cover for correct fit to ensure air-tightness for the actuator housing.

4.5 Electrical connection



Danger of life caused by incompetent staff!

Electrical connections carried out by unqualified staff may result in death, severe bodily injury or considerable material damage.

- Make sure that such all work is carried out by qualified staff.

⇒ 1.3 *Personnel* on page 5



Risk of injury from electric shock by live parts!

When the supply voltage is turned on there is a risk of electric shock from live parts.

- Prior to commencing any work, ensure that the actuator is safely disconnected from the power supply system.
 - Secure against unauthorised restarting.
-

■ **How to prepare the electric connection**

- 1 Ensure that the supply voltage matches the specifications on the type plate of the linear actuator.
- 2 To avoid breakdown, construct the line diameter according to actuating performance and required line length.
- 3 Lay the mains for a supply voltage of > 48 V separate from the signal and control wires.

When laying cables in a joint cable duct, use shielded control wires.

- 4 Check the supply voltage.
If the required tolerance is not achieved by a power transformer you will have to use an AC voltage stabilizer.
⇒ 2.5 *Technical data* on page 10
- 5 Secure the power cables (e.g. with cable-binders) in order to prevent the cable sliding out from the connection terminal.
- 6 Ensure that there is fuse protection for the linear actuator.

■ **How to establish electrical connection**

- 1 Remove the cover (201).
⇒ *How to remove the cover on page 15*
- 2 Run the cable through the screw joint in the cover to the terminal.
- 3 Connect the power supply according to the wiring diagram.
⇒ *diagram 8 on page 17*



Malfunctions caused by incorrect zero potential!

If the electric power supply for the linear actuator is fed by transducing sensors with varying zero potentials this may result in incorrect automatic controller action.

- Ensure that the zero potential is properly applied.
- ⇒ *table 3 on page 18*

- 4 Tighten the screw joints.

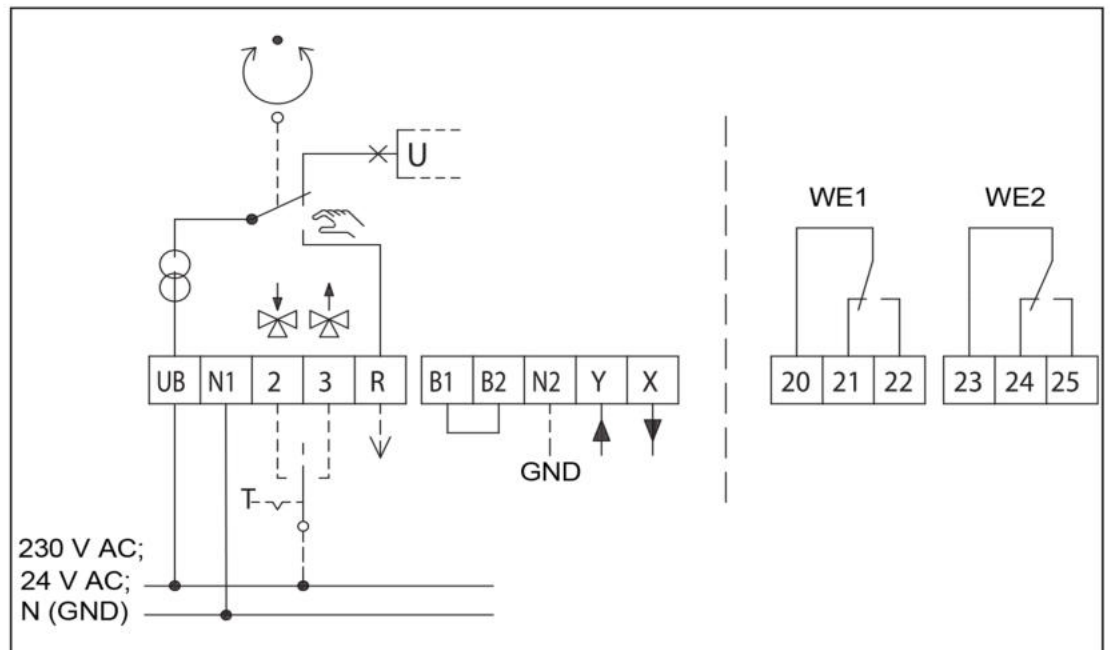

diagram 8 Circuit diagram

Terminal	Description
UB, N1	Supply voltage
2	Control voltage for downward movement during three-point mode
3	Control voltage for upward movement during three-point mode
R	Response signal during "manual" mode • R= 24 V DC max. 35 mA
B1, B2	Binary input / frost protection function
N2	Zero potential of signals X, Y and R • When the zero potentials of signals X, Y and R are identical to the zero potential of the supply voltage it is possible to bridge terminals N1 and N2. • If you run the actuator in continuous mode at 230 V you will have to connect N2. • If you run the actuator in three-point mode at 230 V you will have to connect N2 if you wish to use X or R at the same time.
Y	Input signal continuous mode
X	Output signal continuous mode
20, 21, 22	Terminals path switch unit PS1
23, 24, 25	Terminals path switch unit PS2

table 3 Key to wiring diagram

4.5.1 Controller independent circuit

When working with 24 V supply voltage and 0 ... 10 V DC / 2 ... 10 V DC input signal you can switch the actuator controller-independently via a three-step toggle switch in the control cabinet.

■ How to switch the actuator controller-independently

- 1 Run the supply voltage 24 V AC via a diode and a three-step toggle switch to terminal Y.

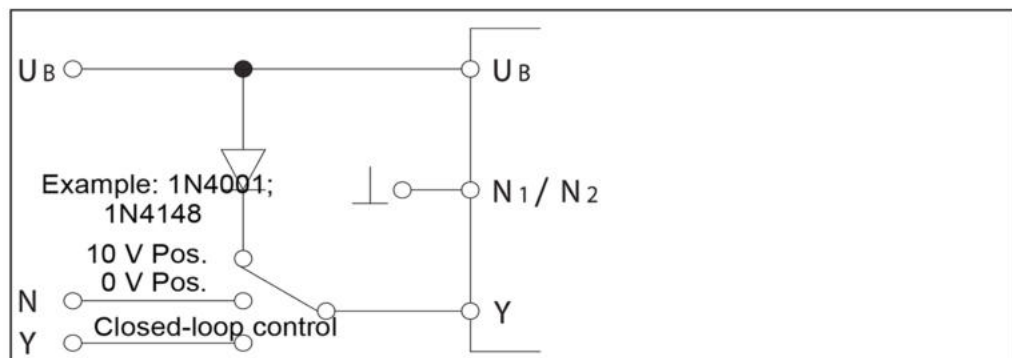
diagram 9 Controller independent circuit

- 2 Using the toggle you can move the linear actuator to the following positions:
 - Closed-loop control by input signal Y (normal operation)
 - 10 V-position
 - 0 V-Position, the linear actuator can be moved to the position selected by encoding switch S6 at 2 ... 10 V DC.
- ⇒ 5.1 Operating parameters and encoding switch settings on page 23
 ⇒ 5.7 Setting the limit position on page 25

4.6 Fitting accessories

Accessories are not part of the scope of delivery for the linear actuator unless expressly ordered! The linear actuators are prepared for retro-fitting with:

- PCB for path switch **(106)**
- PCB for output signal X=0/4 ... 20 mA **(111)**

Hint: Optional operation with mA output signal or path switch possible
 ⇒ 2.2 Accessories on page 7

4.6.1 Fitting a PCB for a path switch



Risk of injury from electric shock by live parts!

When the power supply is on there is a danger of electric shock due to live parts.

- Prior to commencing any work, ensure that the actuator is safely disconnected from the power supply system.
- Secure against unauthorised restarting.

- 1 Open the cover **(201)** of the linear actuator.
 ⇒ 4.4 Assembling/disassembling the cover on page 15
- 2 **24 V:** Clipping the path switch PCB **(106)** to the safety catches on the cover **(201)**
diagram 10 on page 19.
- 3 **230 V:** Push the path switch PCB **(106)** onto the three spacers**(27)** of the push-fit PCB **(107)**.

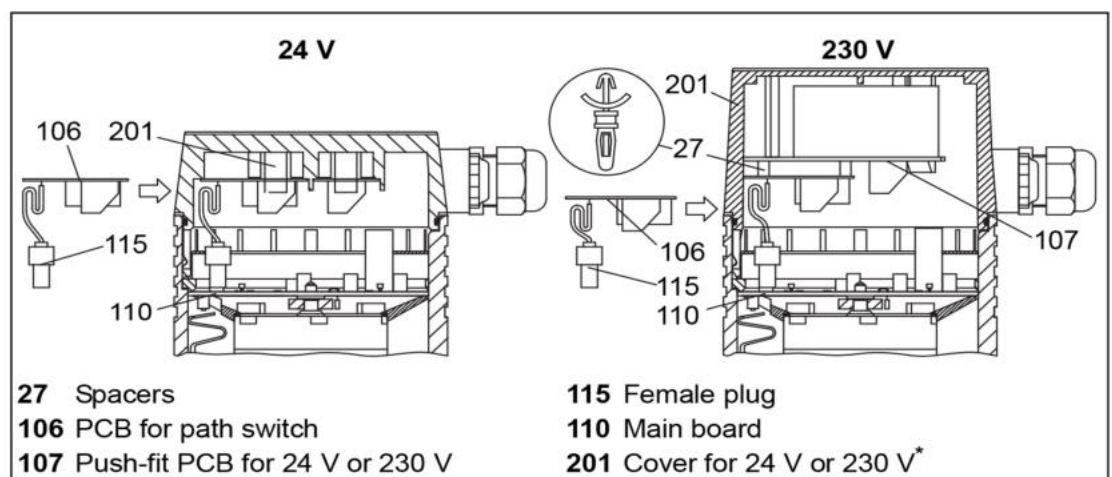

diagram 10 Assembling the path switch PCB inside the cover

- 4 Plug the female plug into the **(115)** path switch PCB **(106)** on the socket board **(123)** of the main PCB **(110)**. In the process pay attention to the notches on the socket board and female plug.

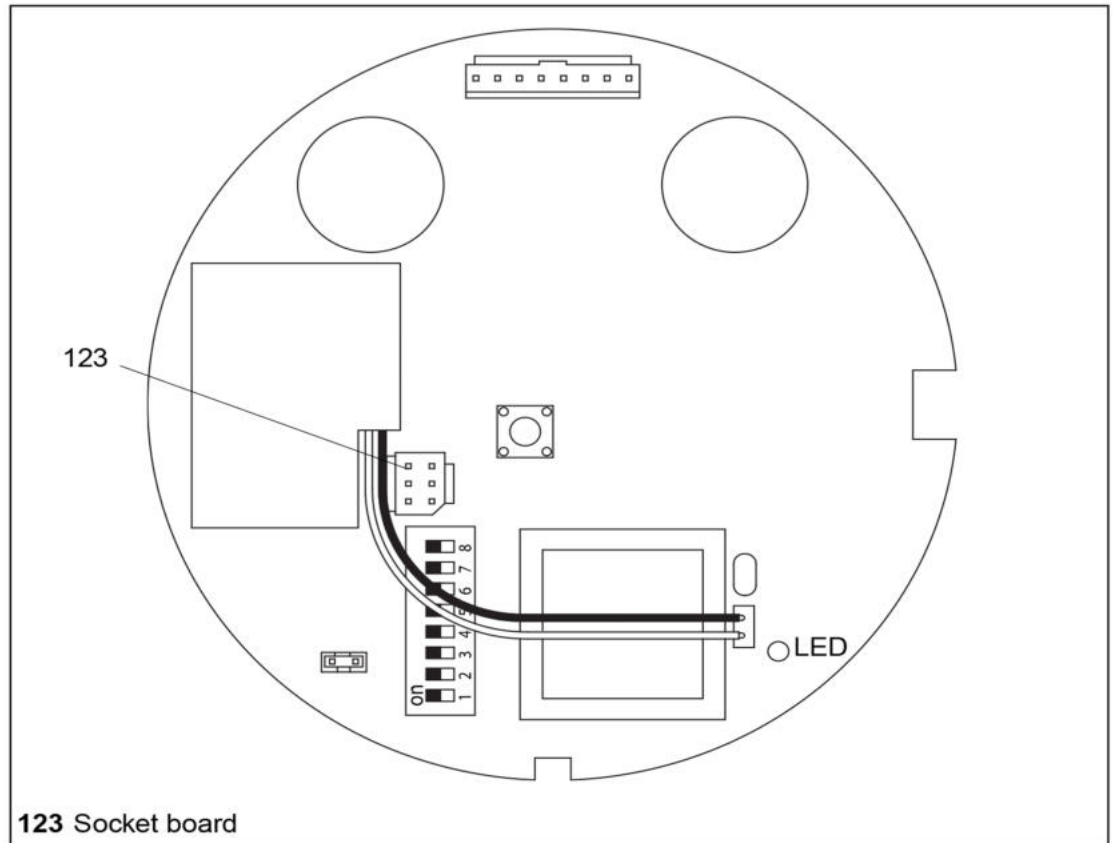

diagram 11 Socket board for position switch PCB on main PCB

- 5** Set the position switches.
⇒ 5.8 *Setting a potential-free path switch* on page 25

4.6.2 Fitting the PCB for the mA output signal



WARNING

Risk of injury from electric shock by live parts!

When the power supply is on there is a danger of electric shock due to live parts.

- Prior to commencing any work, ensure that the actuator is safely disconnected from the power supply system.
- Secure against unauthorised restarting.

- 1** Open the cover **(201)** of the linear actuator.
⇒ 4.4 *Assembling/disassembling the cover* on page 15
- 2** **24 V:** Clip the PCB for the mA output signal to the safety catches inside the cover **(201)**.
230 V: Push the PCB for the mA output signal onto the three spacers of the **(27)** push-fit PCB **(107)**.
⇒ *diagram 12* on page 21

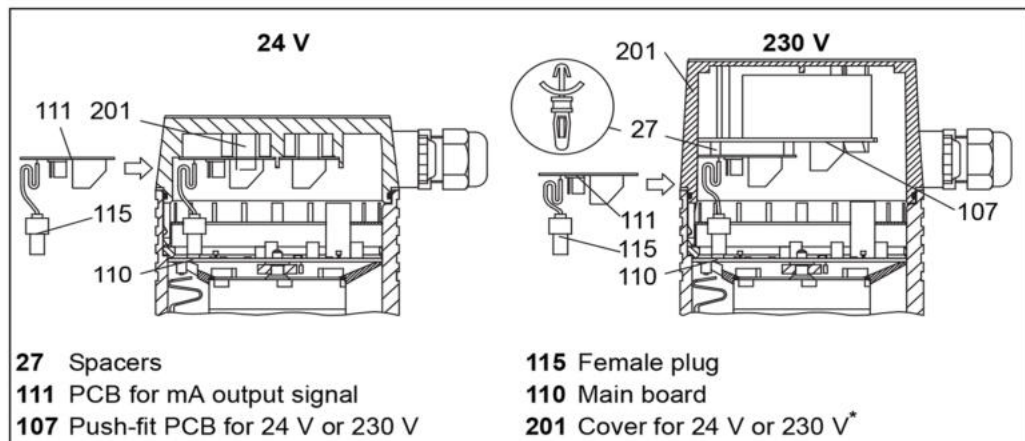

diagram 12 Fitting a PCB for the mA output signal

- 3** Push the female plug of the **(115)** PCB for the mA output signal onto the pin strip **(123)** of the main PCB **(110)** . In the process pay attention to the notches on the socket board and female plug.
- 4** Attach the single cable from the PCB **(111)** for the mA output signal to terminal X of the push-fit PCB **(107)**.
- 5** Use the jumper to select the signal range for the output signal:
 - Jumper right: 4 ... 20 mA
 - Jumper left: 0 ... 20 mA

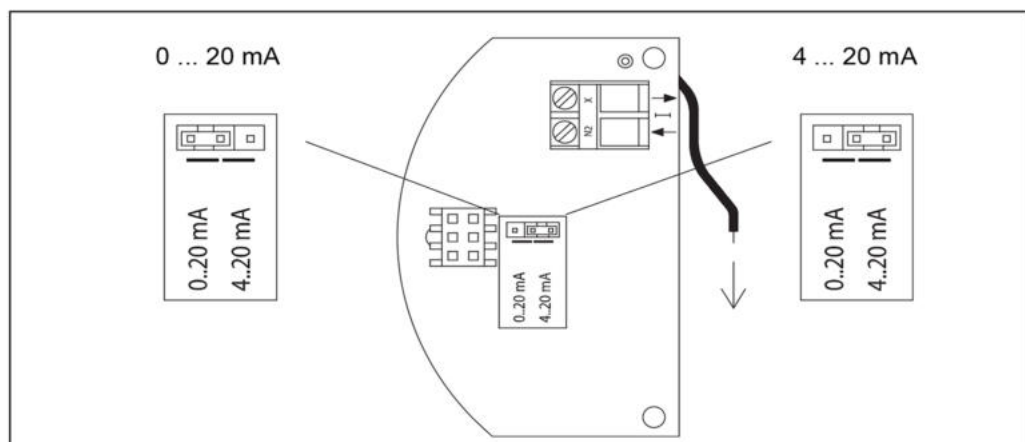

diagram 13 Setting the PCB for the mA output signal

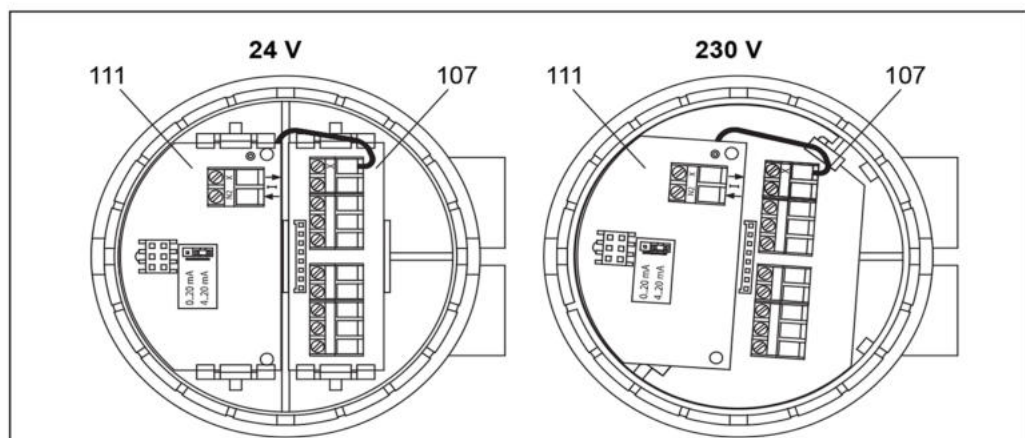

diagram 14 Connecting the PCB for the mA output signal to the push-fit PCB

5 Commissioning



Risk of injury from electric shock by live parts!

When the power supply is on there is a danger of electric shock due to live parts.

- Prior to commencing any work, ensure that the actuator is safely disconnected from the power supply system.
- Secure against unauthorised restarting.

The encoding switches and the **(116)** jumpers are used to **(JP2)** set the operating parameters. Encoding switches and jumpers are situated on the main PCB **(110)**.

⇒ 4.4 *Assembling/disassembling the cover* on page 15

⇒ 4.6 *Fitting accessories* on page 19

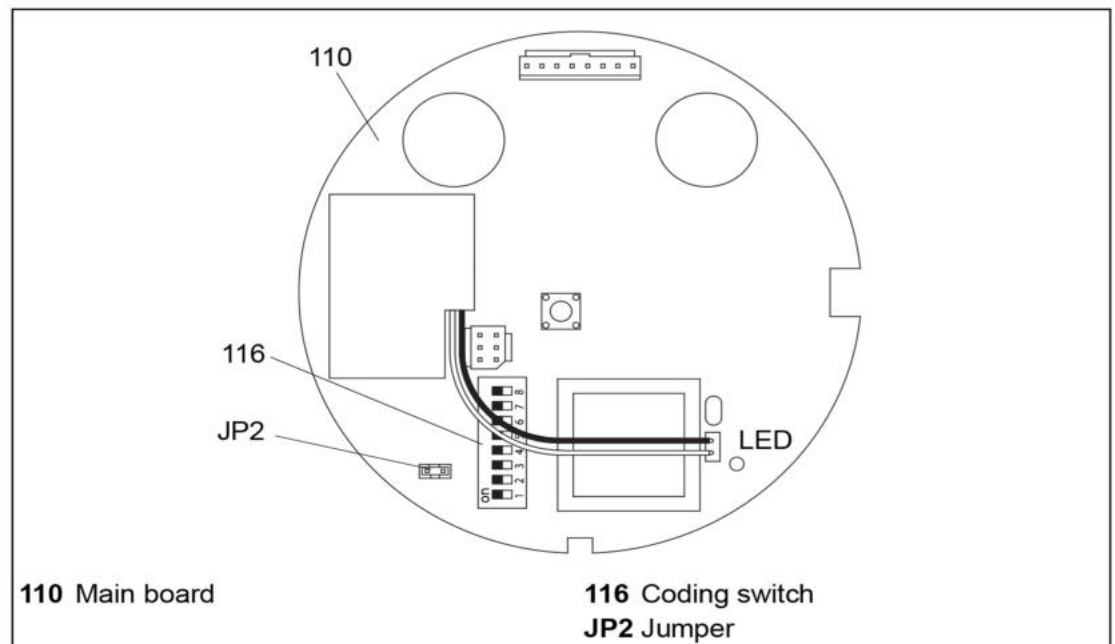

diagram 15 Main PCB, encoding switches and jumpers

5.1 Operating parameters and encoding switch settings

Before starting to operate the linear actuator you will have to set the operating parameters with the help of the encoding switches and jumpers.

Switch / jumper	on	off
S1	X-characteristic line 	X-characteristic line 
S2	Y-characteristic line 	Y-characteristic line 
S3	Input signal (Y) 0 ... 10 V DC or 0 ... 20 mA	Input signal (Y) 2 ... 10 V DC or 4 ... 20 mA
S4	Actuating time 4s/mm	Actuating time 6 s/mm
S5	Auto test and auto pause on	Auto test and auto pause off
S6	Limit position actuator spindle extended	Limit position actuator spindle retracted
S7, S8	S7 and S8 are used to set the hysteresis (0,05...0,5V).	
JP2	Input signal (Y) in mA	Input signal (Y) in V

table 4 Encoding switch and jumper settings

5.2 Setting the input signal

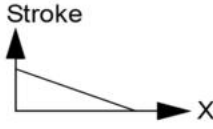
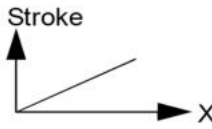
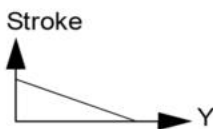
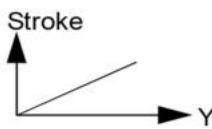
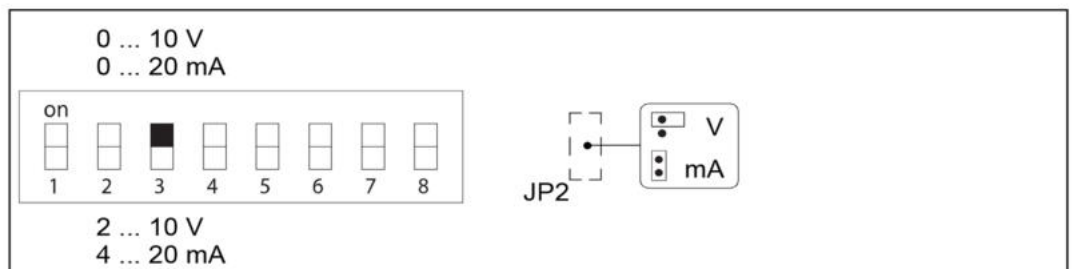

diagram 16 Setting the input signal

⇒ Additional information: *Input signal (Y)* on page 8

5.3 Setting the actuating time

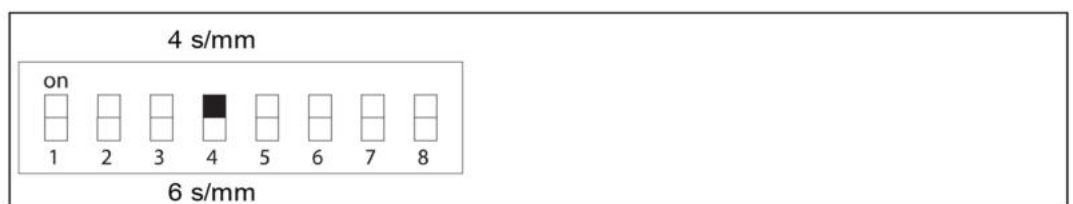

diagram 17 Set actuating time

⇒ Additional information: *2.4.4 Actuating time* on page 9

5.4 Setting the hysteresis

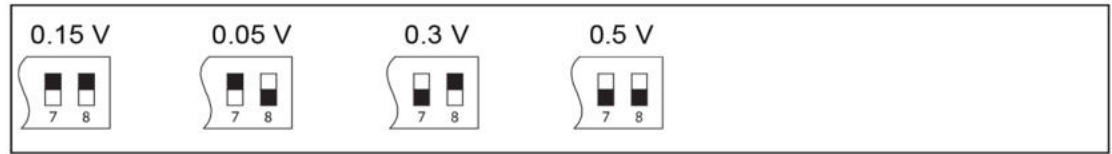

diagram 18 Set hysteresis

⇒ For further information see 2.4.5 Hysteresis on page 9

5.5 Setting the actuating direction

You can use the encoding switch (reverse operation) to reverse the actuating direction of the linear actuator.

Actuator setting	Normal operation	Reverse operation (X and Y reversed)
	<p>Y = 10 V DC Y = 20 mA</p>	<p>Y = 0 V DC Y = 2 V DC Y = 0 mA Y = 4 mA</p>
	<p>Y = 0 V DC Y = 2 V DC Y = 0 mA Y = 4 mA</p>	<p>Y = 10 V DC Y = 20 mA</p>

Encoding switch S1: X (output signal), encoding switch S2: Y (input signal)

table 5 Setting the actuating direction

5.6 Setting auto test and auto pause

Auto test and auto pause are enabled when encoding switch S5 is set to ON. Approximately every 10 days the auto test triggers a start-up towards the limit position in rapid traverse mode. Rebalancing takes place at the same time. During auto pause a break of 3 seconds (measuring cycle 2 min) takes place after more than 20 direction varying traverse commands per minute. These two functions cannot be selected individually.

5.7 Setting the limit position

Use encoding switch S6 to select the limit position for the linear actuator:

- S6 ON: Limit position with extended spindle nut
- S6 OFF: Limit position with retracted spindle nut

The limit position is approached in the following situations:

- Due to wire break detection by the Y signal (2 ... 10 V DC or 4 ... 20 mA only),
- Due to a binary signal (When electric circuit between terminal B1 and B2 is interrupted),
- During auto test
- After a cut in supply voltage (manual adjustment)

5.8 Setting a potential-free path switch

Trim-pots P1/P2 is used to set the path switches independently. Try out the sequence of operations for each position switch once.

■ How to set a path switch

- 1 Ensure that the linear actuator has been commissioned and initialised.
 - ⇒ 5.10 Commissioning on page 28
 - ⇒ 5.9 Initialising the path measuring system on page 27



Malfunction caused by imprecisely set path switches!

If you have set the actuator to manual mode (without supply voltage) it is only possible to set the path switch approximately (central setting is the equivalent of a switch point of c. 50% lift).

- To set the path switch accurately, set the actuator to automatic mode.

- 2 Move the actuator to the position where the switch event is to be triggered. Follow the sequence of operations below with the supply voltage turned on.



Risk of injury from electric shock by live parts!

When the supply voltage is turned on there is a risk of electric shock from live parts.

- Take care not to touch any live parts.
- Take care to apply the tool in a way that does not cause short-circuit.

- 3 Open the cover **(201)**.
 - ⇒ 4.4 Assembling/disassembling the cover on page 15
 Inside the cover is the path switch PCB **(111)**.
- 4 Use a screwdriver to adjust the trim-pot until the path switch switches. The related LED will either light up or switch off.

Potentiometer P1 **(105 P1)** is used to set path switch 1.
LED 1 shows the switching status.

Potentiometer P2 **(105 P2)** is used to set path switch 2.
LED 2 shows the switching status.

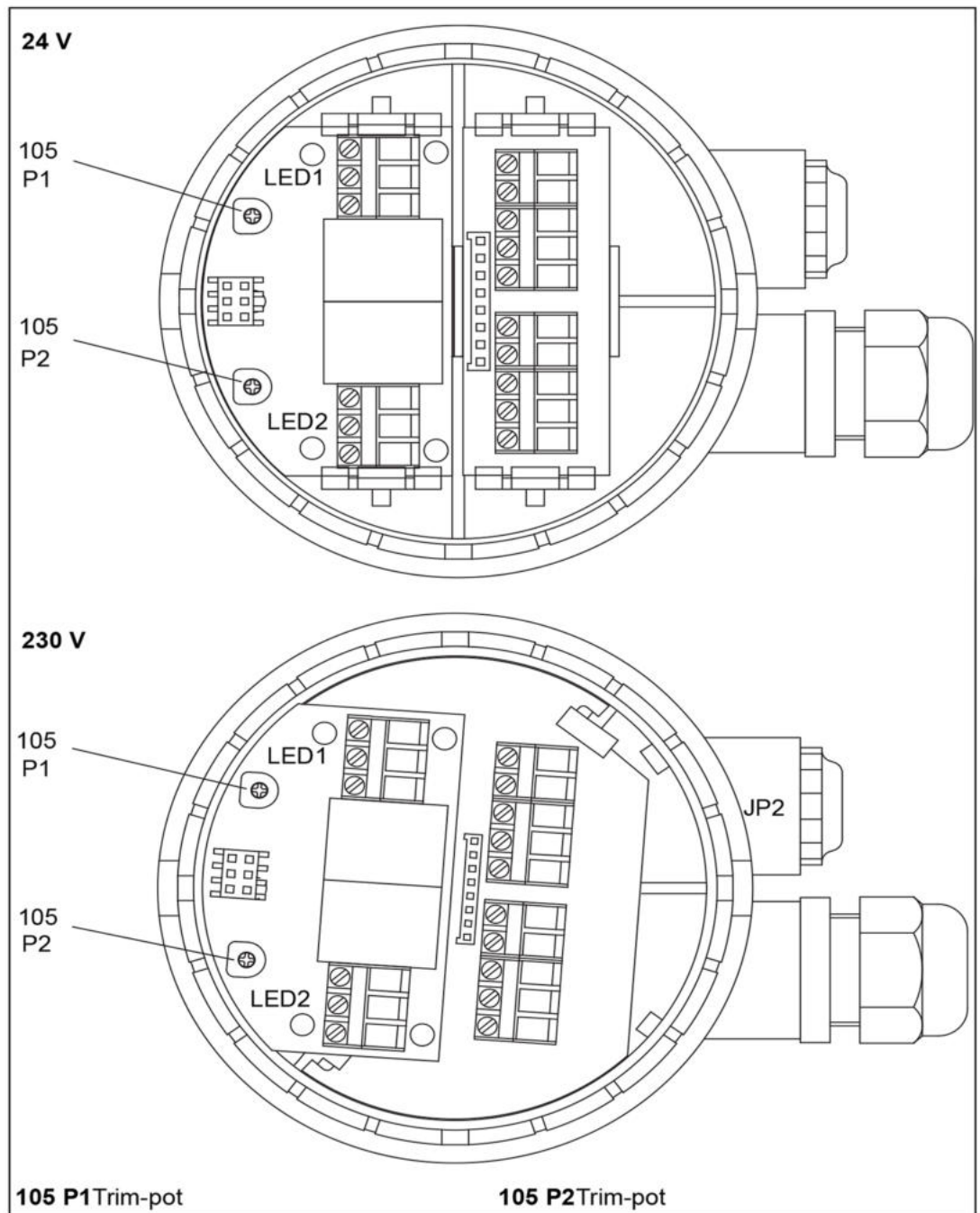

diagram 19 Position switch PCB in cover

- 5** Comply with the allowable contact load for the path switch:

Nominal load	8 A, 250 V AC 8 A, 30 V DC
Switch voltage	max. 400 V AC max. 125 V DC

table 6 Contact load of path switch

- 6** Disconnect the actuator from the supply and connect the path switch contacts.
- 7** Close the cover (**201**) of the linear actuator
- ⇒ *How to attach the cover on page 15*

5.9 Initialising the path measuring system



Linear actuator starts automatically!

The linear actuator starts immediately after being connected to the supply voltage and automatically moves to a reference point of the path measuring system.

- Wait until this reference point has been reached and the linear actuator has stopped.

The path measuring system has to be initialised after the following:

- At initial commissioning
- After repairs to the valve or actuator
- After a replacement of valve or actuator

Initialisation may be triggered in two different ways.

■ How to initialise via the initialising button



Risk of injury from electric shock by live parts!

When the supply voltage is turned on there is a risk of electric shock from live parts.

- Take care not to touch any live parts.
- Take care to apply the tool in a way that does not cause short-circuit.

- 1 Open the cover **(201)**.
⇒ 4.4 *Assembling/disassembling the cover* on page 15
- 2 Ensure that supply voltage is applied.
- 3 After applying the supply voltage the emergency actuating unit (NE) will automatically be tensed by the actuator. After tensing the actuator will remain in bottom limit position.
- 4 After a waiting period of c. 25 seconds push and hold the initialising button **(118)** for at least 2 seconds (stopping time). After the initialising cycle the actuator will follow the actuating signal.

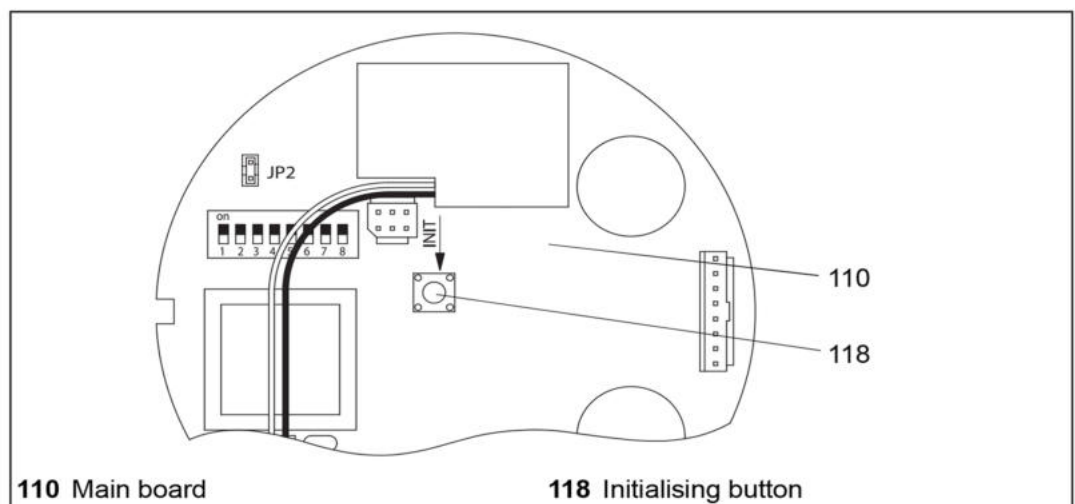

diagram 20 Initialising the path measuring system

5.10 Commissioning

- 1** Check whether all fitting and assembly work has been competently finished.
⇒ *4 Assembly on page 12*
- 2** Ensure that the electrical actuation of the linear actuator can take place safely without putting people or devices at risk.
- 3** Ensure that the linear actuator is attached correctly and that the cover of the linear actuator is closed.
⇒ *4.4 Assembling/disassembling the cover on page 15*
- 4** Ensure that the linear actuator is set to automatic mode.
⇒ *6.1 Changing between manual and automatic mode on page 29*
- 5** Ensure that the operating parameters are set correctly.
⇒ *5.1 Operating parameters and encoding switch settings on page 23*
- 6** Ensure that the path measuring system is initialised.
⇒ *5.9 Initialising the path measuring system on page 27*
- 7** Apply supply voltage. Afterwards the linear actuator will tense the emergency actuating unit.

The linear actuator is ready for operation.

6 Operation

Prior to commissioning the linear actuator you will have to initialise it and select the operating mode.

⇒ 5 Commissioning on page 22

⇒ 5.9 Initialising the path measuring system on page 27

6.1 Changing between manual and automatic mode

It is possible to run the linear actuator in automatic mode or manual mode (manual adjustment). During manual mode you will only be able to change the lift when voltage is applied and the spring of the response unit is in a tensed state.

- In automatic mode the spindle nut moves to the position set by the controller.
- In manual mode it is possible to set the spindle manually, e. g. for control purposes. Output signal (X) is not available in manual mode.

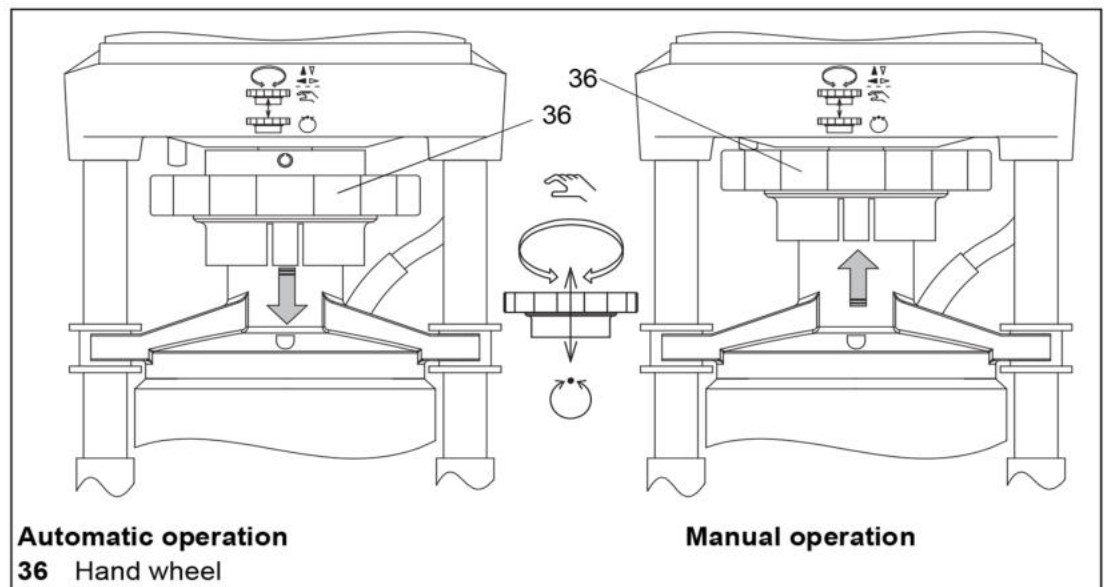

diagram 21 Selecting automatic mode

■ How to change-over in manual mode

- 1 Move the hand wheel (36) to manual mode position by turning until the hand wheel locks noticeably.



Risk of damage to valve and actuator during manual mode!

The valve may get damaged if it is pushed too hard into its receptacle during manual mode.

- Do not try and keep turning the hand wheel when you realise that the required effort increases noticeably!
- Never use force !

- 2 Use the hand wheel to turn the spindle nut to the desired position. Turn the hand wheel until the preset potentiometer increases. Do not use force!

■ **How to change-over in automatic mode**

- 1 Push the hand wheel **(36)** to automatic mode position.
- 2 The linear actuator first moves to the position specified by encoding switch S6 and then to the position preset by the controller.

6.2 LED display

The LED on the main PCB in the actuator indicates the operating status or errors.

⇒ 10.2 Check list for breakdown on page 32





LED	Operating status / error
 Duration	Normal operation, ready for operation The LED is permanently lit, actuator waiting for traverse command.
 0,5s 0,5s 0,5s 0,5s	Standard Operation Actuator carries out traverse command.
 0,2s 1,5s 0,2s 1,5s Short – long rhythm	Wire break detection Input signal has dropped below 1 V or below 2 mA in operating modes 2 ... 10 V DC or 4 ... 20 . ⇒ 2.4.3 Wire break detection on page 8
 2,5s 2,5s 2,5s 2,5s Long – long rhythm	Blockage detection (continuous mode only) The linear actuator is mechanically blocked. ⇒ 2.4.2 Blockage detection on page 8
 1,5s 0,2s 1,5s 0,2s Long – long rhythm	Continuous signal on terminal 2 and 3 A simultaneous control signal at terminal 2 and 3 will result in an initialising cycle (max. 4 attempts). The linear actuator will automatically switch off after 4 unsuccessful attempts.

table 7 Display LED

7 Maintenance, care and repairs

The linear actuator requires little maintenance. You do not have to carry out continuous or periodical maintenance.

8 Spare parts

When ordering accessories and spare parts please quote the specifications engraved on the type plate of your linear actuator. The specifications on the type plate are standard for the technical date of linear actuators as well as the requirements for the public power supply.



Damage to device caused by faulty spare parts!

Spare parts must match the technical data specified by the manufacturer.

- Use genuine spare parts at all times.

⇒ 2.1 Component parts on page 6

⇒ 2.2 Accessories on page 7

9 Decommissioning and disposal

Dispose of the linear actuator according to national regulations and laws.

10 Removal of faults

After remedying faults you will have to re-initialise the path measuring system.

⇒ 5.9 Initialising the path measuring system on page 27

10.1 How to remedy faults

If the linear actuator does not work properly follow the sequence of operations described below in order to remedy the fault:

- 1 Check whether the linear actuator was correctly assembled.
- 2 Check the settings for the linear actuator against the specifications on the type plate.
- 3 Remedy the fault by following the check list.
⇒ 10.2 Check list for breakdown on page 32
- 4 If you are unable to remedy the fault contact the manufacturer.
- 5 For all queries at the manufacturer's and when sending back the device please quote the following :
 - SN (serial number = order number)
 - Type denomination
 - Supply voltage and frequency
 - Accessory equipment
 - Error report
- 6 If you are unable to remedy the fault despite inquiry you can send the device to the manufacturer.

10.2 Check list for breakdown

Fault	Cause/reason	Remedy
1. Linear actuator is not working.	Hand wheel (36) is in position manual mode	<input type="checkbox"/> Switch hand wheel to position automatic mode.
	Power cut	<input type="checkbox"/> Determine cause and remedy.
	Fuse defective (in control cabinet)	<input type="checkbox"/> Determine cause and remedy, replace fuse.
	Linear actuator incorrectly connected	<input type="checkbox"/> Set connection correctly according to wiring diagram (on cover).
	Short circuit due to humidity	<input type="checkbox"/> Determine cause, dry the linear actuator; replace cover seal or screw joints and/or attach protective cover, as required.
	Short circuit due to incorrect connection	<input type="checkbox"/> Correct setting for connection
2. Linear actuator running unsteadily, i. e. veering between clockwise and anti-clockwise rotation.	Drop of voltage due to excessively long connecting cables and / or insufficient diameter.	<input type="checkbox"/> Measure the current data; if required, recalculate and replace connecting cables!
	Public power supply fluctuations greater than admissible tolerance ⇒ 2.5 <i>Technical data</i> on page 10	<input type="checkbox"/> Improve public power supply conditions
3. Linear actuator pauses intermittently or initialises frequently	Slack contact in feeder line	<input type="checkbox"/> Check and tighten connections (terminal strips)
4. Linear actuator does not move to limit position. Valve does not open/close.	Valve is stuck	<input type="checkbox"/> Provide smooth-running valve
	Excessive system pressure	<input type="checkbox"/> Adjust system pressure
5. Linear actuator does not move at all or not correctly to the position preset by input signal Y	Input signal Y is faulty: <ul style="list-style-type: none"> • Interfering signals • Signal variations 	<input type="checkbox"/> Check input signal Y on linear actuator, remove cause of fault
	Main PCB defective	<input type="checkbox"/> Replace main PCB or disassemble linear actuator and send it in for repair
6. LED flashes in long / long rhythm	Blockage detection was triggered	<input type="checkbox"/> Press INIT and observe actuator during initialisation.
		<input type="checkbox"/> Check valve for smooth-running along entire traverse range
7. LED flashes in short / long rhythm	Wire break was detected	<input type="checkbox"/> Measure desired value voltage and current on linear actuator
8. LED flashes in long / short rhythm	Relay contact adhesive	<input type="checkbox"/> Check controller

table 8 Check list breakdown